

ERS VAR 11-01 for the Elevator Market

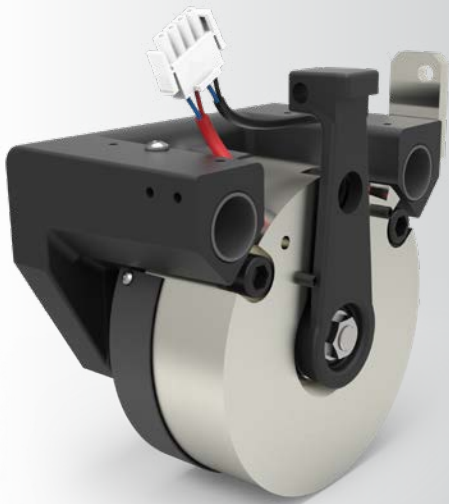

Elevator Applications

- Gearless Motors
- Gear Motors

ELECTRICALLY RELEASED BRAKE FOR ELEVATORS

Electrically Released Safety Brake Caliper

The VAR 11-01 is a highly modular braking system for modern elevators that is particularly suitable for flat gearless motors. The VAR 11-01 operates in static and/or emergency stops.

- Torque according to disc diameter and number of calipers
- Floating magnet and fixed disc
- Complies with Directive 2014/33/EU
- Hand release equipped
- Redundant capability according EN81-20/50 when two or more brakes are used
- Overexcitation (dual voltage)
- Microswitch equipped
- Very easy installation
- Nearly maintenance free (further information in our service manual)
- No airgap adjustment required

www.warnerelectric.com

WARNER ELECTRIC™
A REGAL REXNORD BRAND

ERS VAR 11-01

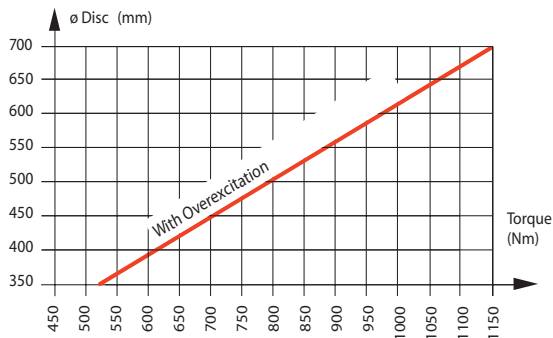
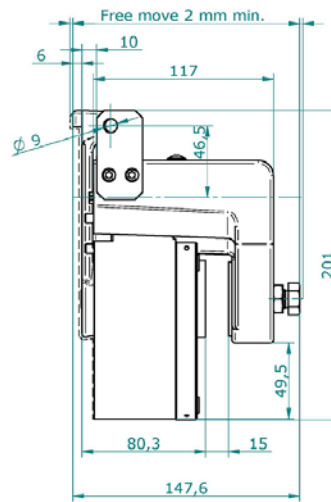
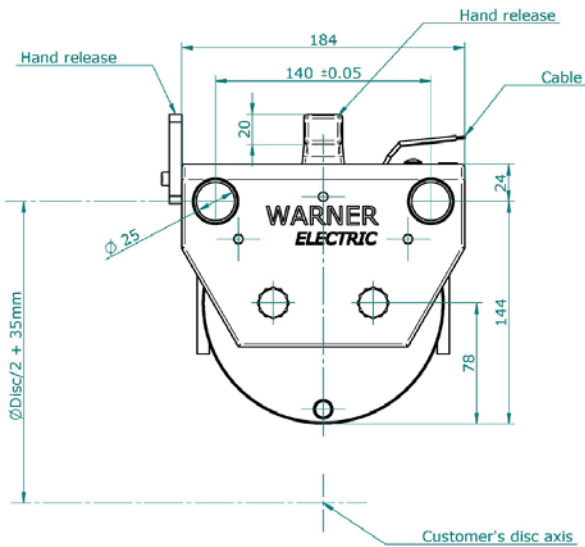

Linear speed (outer diameter of disc):
standard up to 15 m/s

Friction material: Steel or grey cast iron

Subject to alteration without prior notice.

Voltage (VDC)

With Overexcitation

Holding Voltage	Overexcitation Voltage
24	48
52	103.5
103.5	207

ED=50%

Tolerances on the supply voltage at the brake terminals
+5% / -10% (NF C 79-300).