

Multi-Disc Brakes

SAE Series

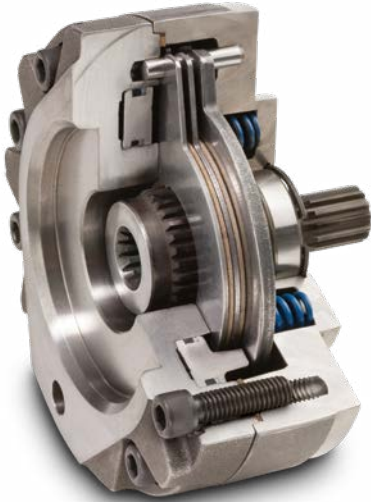

SAE Series Multiple Disc Hydraulic Bolt-On Brakes

For Wet or Dry Operation

SAE Series Hydraulic Brakes are the perfect choice for mobile equipment wheel drives, track drives, winch drives and other hydraulic and motor driven equipment where power off braking is required. SAE brakes are widely used in these mobile equipment applications where failsafe brake operation is essential for parking in the event of a power loss.

Industries served:

- Mining Vehicles
- Mobile Boom and Platform Lifts
- Agricultural Vehicles
- Special Purpose Vehicles

The SAE Series multi-disc, hydraulic brakes are designed as wet or dry parking brakes. Typically mounted between a hydraulic motor and a reducer, these brakes are designed to release at hydrostatic transmission pump pressure changes.

Why customers choose the SAE Series:

- Robust brake construction with high grade castings enables the brake to continuously hold 3,000 psi and 4,000 psi peak pressures
- Sealed construction keeps harmful contaminants out
- Spring applied hydraulic release operation ensures safety
- Bearing supported shaft ensures alignment for easy assembly
- Silicon chrome springs offer longer service life and high torque output
- SAE standard interface enables easy installation
- Advanced friction material provides improved all-round brake performance
- Close dynamic/static performance for smooth deceleration and E-stop when required
- Wet or dry options available for service or parking brakes
- Once they are installed, the brakes are fully sealed and can handle a variety of tough environments
- Suitable for mining applications
- SAE Series bolt-on brakes are a cost effective solution, particularly for straight fixed axle vehicles

SAE Series Multiple Disc Hydraulic Bolt-on Brakes

A Cost-Effective Brake Solution for Mobile Equipment

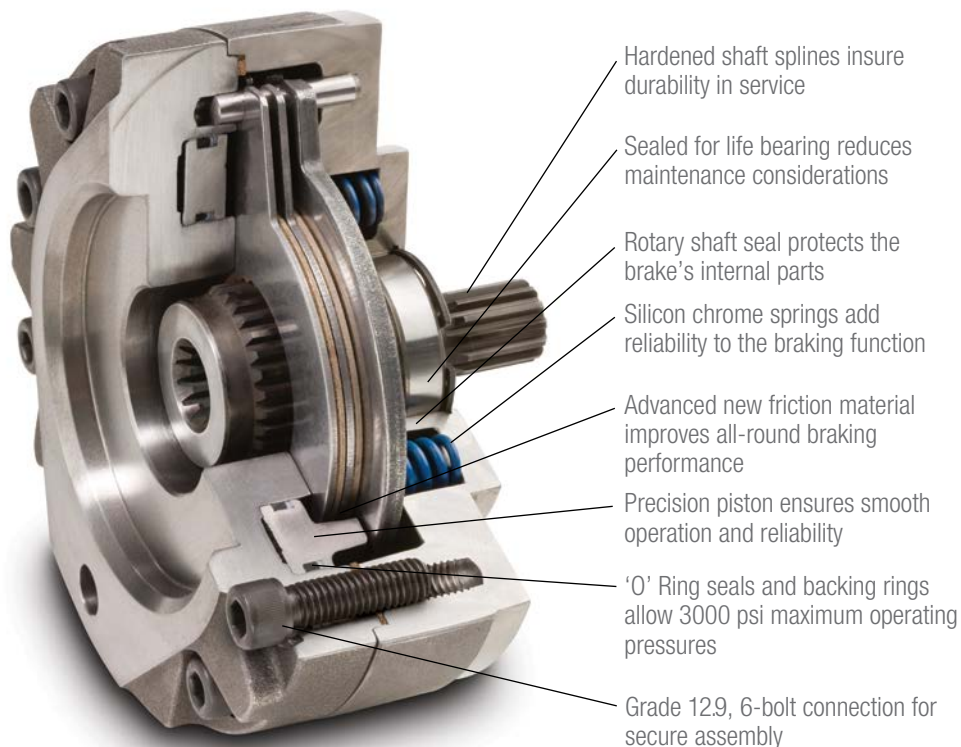

Matrix Brake Series	SAE Bolt-On Configuration	Rated Dry Static Torque Range		Rated Wet Static Torque Range		Full Release Pressure Range		Brake Unit Weight	
		lb.-in.	(Nm)	lb.-in.	(Nm)	psi	(Bars)	lb.	(kg)
AHBS	"A/B" Short	800-2,400	(90-270)	500-1,600	(56-180)	66-195	(4.6-13.4)	23	(10.4)
BHBS	"B" Short	800-2,400	(90-270)	500-1,600	(56-180)	66-195	(4.6-13.4)	21	(9.5)
AHB	"A/B"	1,000-3,600	(113-405)	1,000-2,400	(113-270)	66-195	(4.6-13.4)	27	(12.2)
BHB	"B"	1,000-3,600	(113-405)	1,000-2,400	(113-270)	66-195	(4.6-13.4)	25	(11.3)
CHB	"C"	4,000-10,000	(450-1130)	2,600-6,600	(290-945)	95-235	(6.5-16.2)	52	(23.6)
DHB	"D"	7,000-14,000	(790-1580)	4,600-9,300	(520-1050)	85-170	(5.9-11.7)	105	(47.6)