

# Air Conditioning Clutch

## Troubleshooting Guide

P-1011-WE  
819-0505

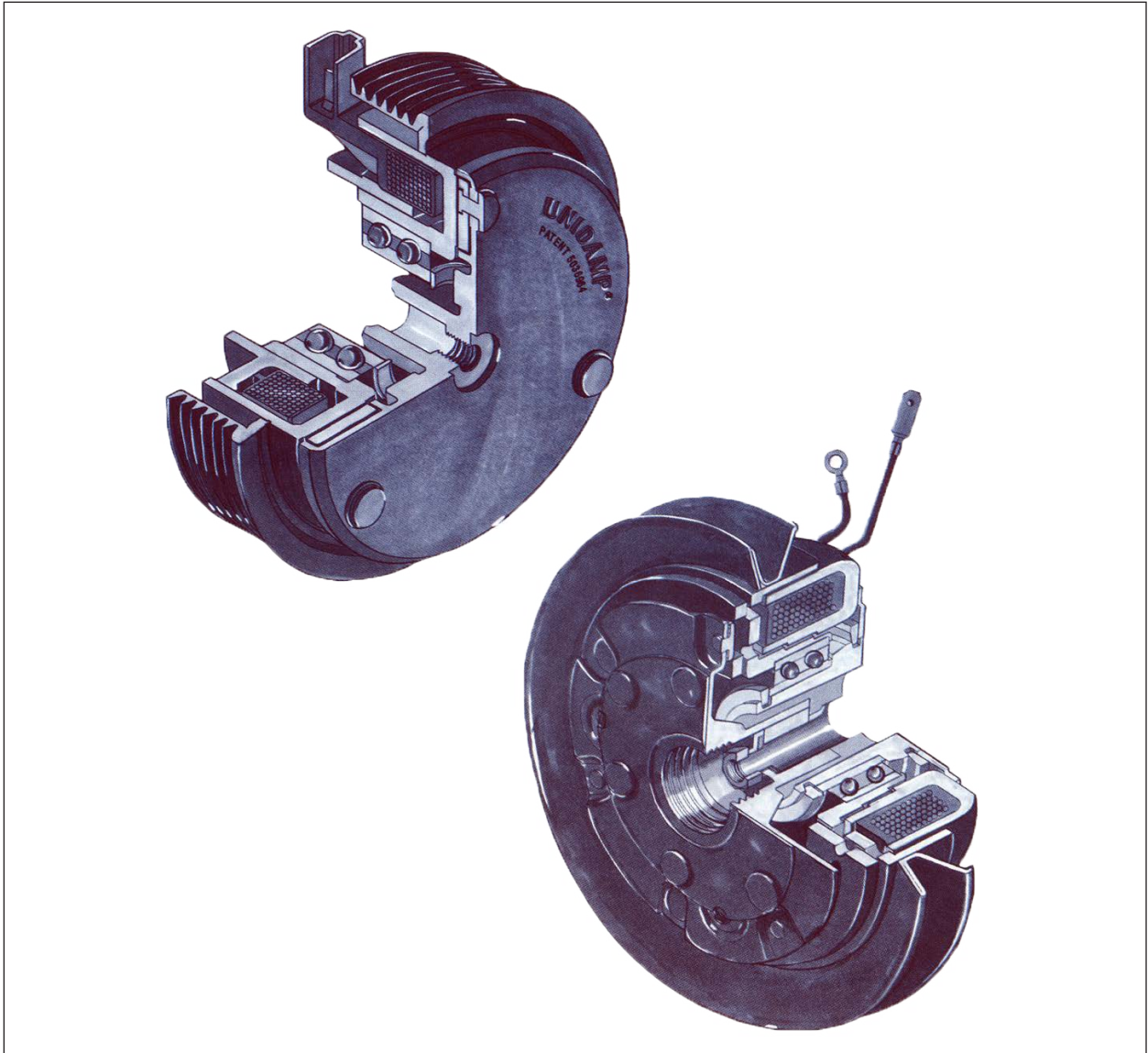

 **Warner**<sup>®</sup>  
Electric

An **Altra Industrial Motion** Company

# INTRODUCTION

---

This Troubleshooting Guide has been prepared to provide mechanics and service personnel with an organized approach to diagnosing A/C clutch problems, finding the PRIMARY causes of those problems, and repairing them.

In many cases, clutch problems or failures have causes other than the clutch itself. These may include other components in the air conditioning system or even improper clutch installation. Consequently, an accurate problem diagnosis must include examination of all possible causes. To prevent a problem or failure from recurring, the original or PRIMARY FAILURE CAUSE must be determined. This is the starting cause of the chain of events which leads to the clutch failure. Subsequent problems or failures that happen as a result of the primary failure cause are called SECONDARY FAILURE CAUSES. Obviously, these secondary failure causes must be corrected. But, if only the secondary problem is

fixed and the primary cause is not addressed, the failure may occur again.

For example, a compressor may leak oil through its front seal and contaminate the working faces of the clutch. This is the primary cause of the failure. The clutch slips and the resulting heat buildup causes a "wet slip and burn" type of clutch failure. This is the secondary failure cause. If the clutch only is replaced, the compressor will continue to leak and the failure can recur. If the compressor seal problem is corrected (the PRIMARY failure cause) and the clutch is replaced, the problem should not happen again.

The procedures in this guide can help you discover PRIMARY failure causes. Repairing primary causes, as well as secondary causes, should result in more satisfied customers and increased warranty claim accuracy.

## How to Use This Guide

1. Select the problem in the Table of Contents which matches your particular situation.
2. Turn to the section in the manual that describes the problem.
3. Follow the inspection steps listed in the first column.
4. The instructions will lead you to a PRIMARY FAILURE CAUSE in the second column.
5. Complete the corrective action listed in the third column.

Two types of clutches are covered in this manual, "typical" clutches and Warner Electric's World Clutch. The troubleshooting sequences which follow apply equally to both types, except where noted as World Clutch only. These sections are darkened to easily distinguish them. Since the World Clutch is significantly different from "typical" clutches, a separate cutaway view is offered on page 3.

## Table of Contents

Terminology, Typical Clutch .....	Page 3
Terminology, World Clutch .....	Page 3
The clutch is BURNED .....	Pages 4 through 8
The clutch is SLIPPING .....	Pages 9 through 11
The clutch is NOISY .....	Pages 12 through 15
The clutch will NOT ENGAGE .....	Pages 16 through 17
The clutch will NOT DISENGAGE .....	Pages 18 through 19

**NOTE:** The information contained in this manual is believed to be correct, but Warner Electric disclaims any liability regarding the use of the information contained herein.

# TERMINOLOGY

The following illustration shows cutaways of a Typical Clutch and World Clutch. The component names used in this guide are in bold on the illustration. Common names are listed in brackets under the component names.

## Typical Clutch

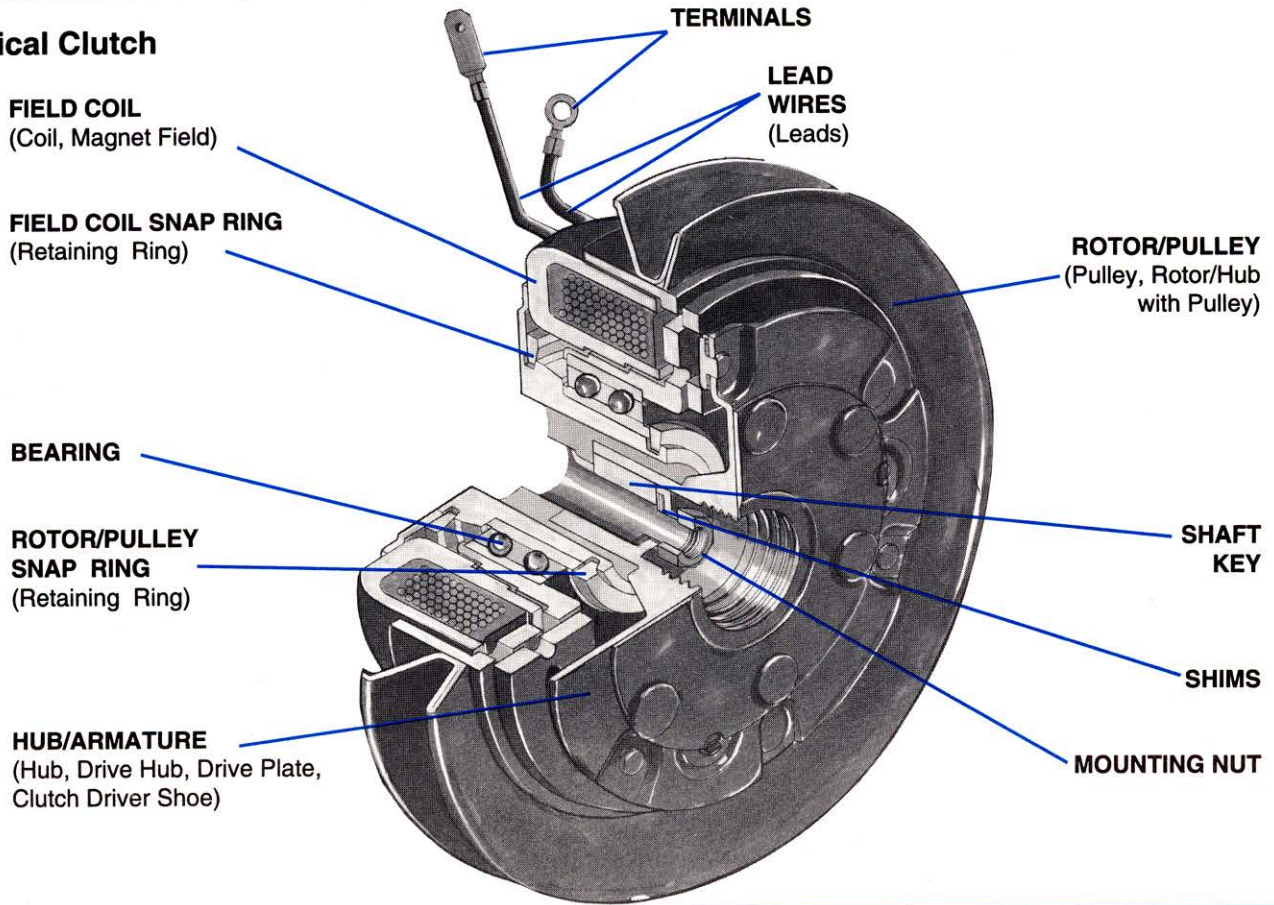

## World Clutch

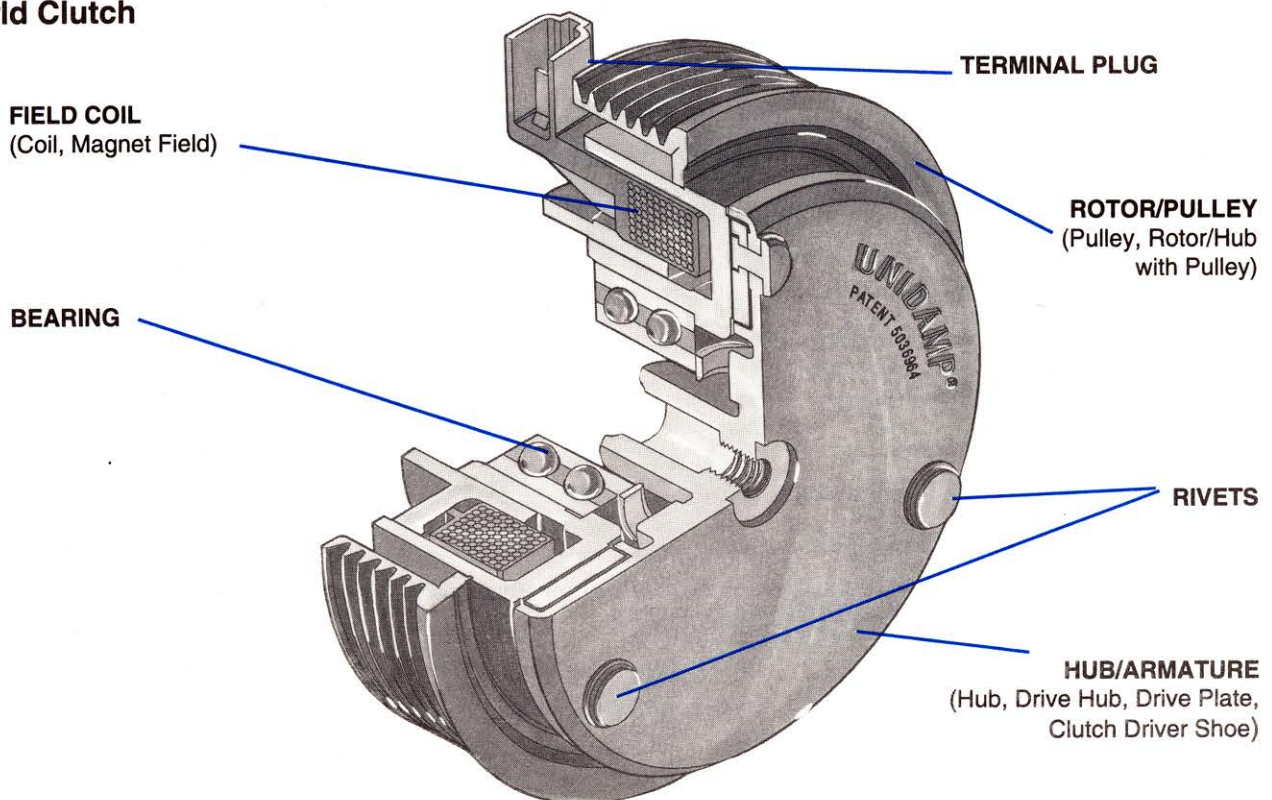

# THE CLUTCH IS BURNED

## Description

Generally, a burned clutch is a result of prolonged slipping or component rubbing. It has been subjected to extreme heat generated by slipping or rubbing friction and may exhibit charred or burned paint, blued steel surfaces, melted or brittle bearing seals, damaged bearings, purged bearing grease, broken springs or a melted or charred field.

**NOTE:** This burned clutch description does not apply to Warner Electric's World Clutch, whose Unidamp® armature provides an effective thermal fuse that activates when torsional overload and/or overheating occur. Heat generated by slippage in a World Clutch activates the thermal fuse and releases the load before bearing failure occurs.

Even though a burned clutch may appear to be totally destroyed, subtle indicators may identify the primary failure cause. The procedure listed below will guide you to the most common causes of a burned clutch failure.

Typically, bearing failure in a burned clutch is NOT the primary cause. The bearings fail from excessive heat generated during the burn process. The heat melts the ball cages and or hardens the seals, allowing the grease to purge, leading to a total failure.

INSPECTION	PRIMARY CAUSE(S)	CORRECTIVE ACTION
------------	------------------	-------------------

### STEP 1A

Is oil or grease on the clutch or on the hub/armature and rotor/pulley drive faces? See Figure 1.

#### IMPORTANT

**ALWAYS** replace rotor/pulleys and hub/armatures in pairs.  
**NEVER** mix new and used rotor/pulleys and hub/armatures or clutch failure may result.

**YES** →

**NO.** Proceed to STEP 2.

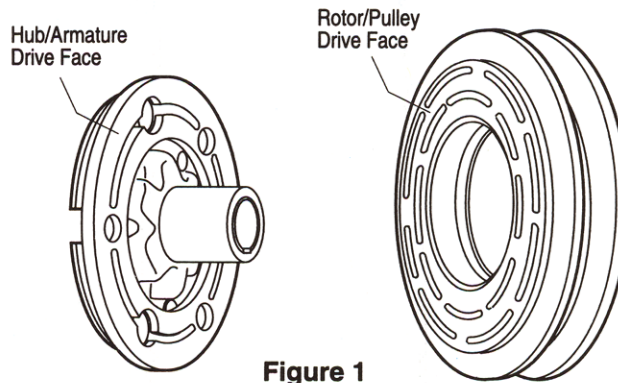

Figure 1

- A. Compressor shaft seal leak.
- B. Compressor through-bolt leak.
- C. External oil source, such as engine oil, power steering fluid, etc.

Replace clutch.  
Locate source of oil and/or grease and repair.  
Replace or repair compressor as required.

### STEP 1B World Clutch only

is Unidamp® drive separated from armature disk?

#### IMPORTANT

**ALWAYS** replace rotor/pulleys and hub/armatures in pairs.  
**NEVER** mix new and used rotor/pulleys and hub/armatures or clutch failure may result.

**NO.** Proceed to STEP 2.

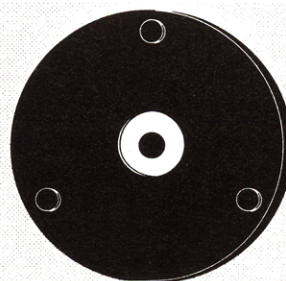

Thermal Fuse

- A. Compressor lock up
- B. Compressor shaft seal leak.
- C. Compressor through-bolt leak.
- D. External oil source, such as engine oil, power steering fluid, etc.



Thermal Fuse Activated

Replace clutch.  
Locate source of oil and/or grease and repair.  
Replace or repair compressor as required.

# THE CLUTCH IS BURNED

INSPECTION	PRIMARY CAUSE(S)	CORRECTIVE ACTION
------------	------------------	-------------------

## STEP 2

Remove the hub/armature. Is the rotor/pulley snap ring missing or improperly installed? See Figure 2.

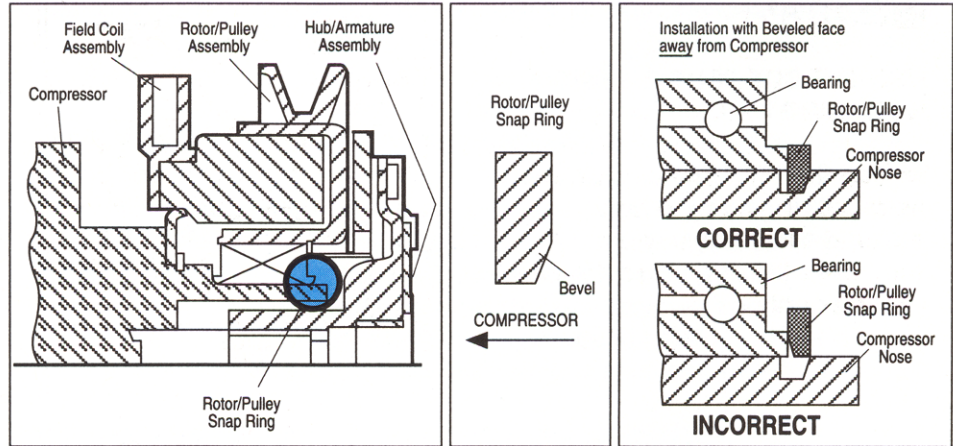

**A**  
Location of Rotor/Pulley Snap Ring

**B**  
Rotor/Pulley Snap Ring Bevel

**C**  
Correct and Incorrect Installation

**Figure 2**

**YES** →

The rotor/pulley snap ring was not installed or was improperly installed.

Replace the clutch.  
Repair or replace compressor as required.

### IMPORTANT

- The bevel on the rotor/pulley snap ring **MUST** face away from the compressor. See Figures 2A, B, C.
- The rotor/pulley snap ring must be seated fully in the groove. See Figure 2C.

**NO.** Proceed to STEP 3.

## STEP 3

Remove the rotor/pulley. Is the field tight on the compressor? (Meaning the field coil cannot be rotated by hand or moved axially on the compressor).

**YES.** Proceed to STEP 5 (Page 8).

**NO.** Proceed to STEP 4

## STEP 4

Is the field coil snap ring the correct ring? See Figure 3. Is it installed correctly? See Figure 4, page 6.

### IMPORTANT

#### USE THE CORRECT RETAINING RING

During the 1981 model year, the field coil ring used to hold the field assembly in place was made thicker. (Ford FS-6 and Chrysler only).

Warner Electric • 800-825-9050

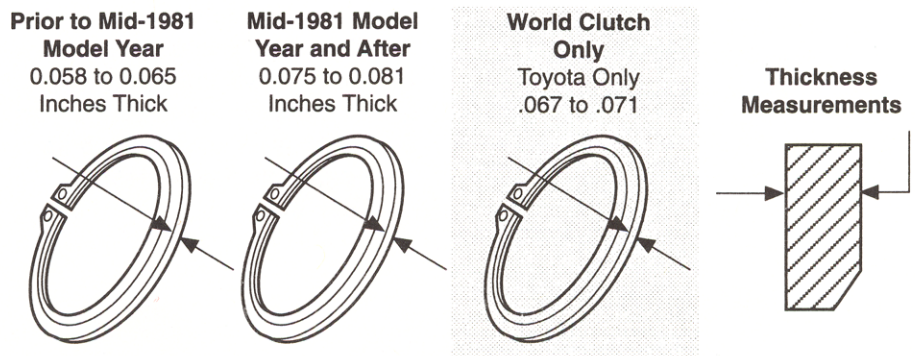

**Figure 3**

# THE CLUTCH IS BURNED

INSPECTION	PRIMARY CAUSE(S)	CORRECTIVE ACTION
------------	------------------	-------------------

## IMPORTANT

### USE THE CORRECT RETAINING RING

During the 1981 model year, the field coil ring used to hold the field assembly in place was made thicker. (Ford FS-6 and Chrysler only).

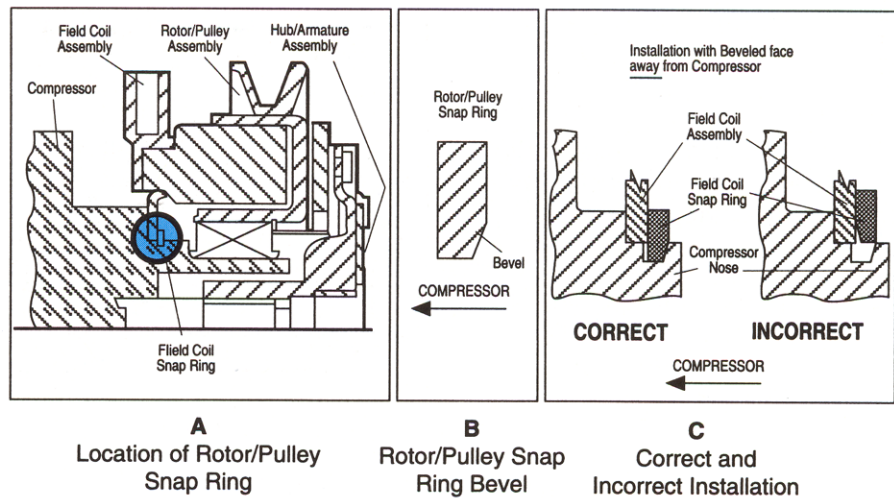

**Figure 4**

**YES.** Proceed to STEP 5 (Page 8).

**NO.** →

A. Wrong field coil snap ring.

Repair or replace compressor as required.

Replace clutch if damaged.

Be sure to use the correct field coil snap ring. See Figure 3.

NOTE: Check the compressor for anti-rotation pin damage.

A typical indicator of improper field coil snap ring installation is rubbing between the field coil and rotor/pulley poles. See Figure 5. Also, if the field coil has an anti-rotation hole, the hole may be elongated or deformed from beating against the anti-rotation pin. See Figure 6.

B. Field coil snap ring installed incorrectly.

## IMPORTANT

- The bevel on the field retaining ring **MUST** face away from the compressor. See Figures 4A, B, C.
- The field retaining ring must be seated fully in the groove. See Figure 4C.
- The lug of the field retaining ring must **NOT** be positioned over the anti-rotation pin. See Figure 7.
- The field must be tight against the compressor.

# THE CLUTCH IS BURNED

INSPECTION	PRIMARY CAUSE(S)	CORRECTIVE ACTION
------------	------------------	-------------------

**STEP 4 (Continued)**

**B. Field coil snap ring installed incorrectly.**

**NOTE:** Check the compressor for anti-rotation pin damage. Repair or replace compressor as required. Replace clutch if damaged. Be sure to use the correct field coil snap ring. See Figure 3.

**Figure 5**

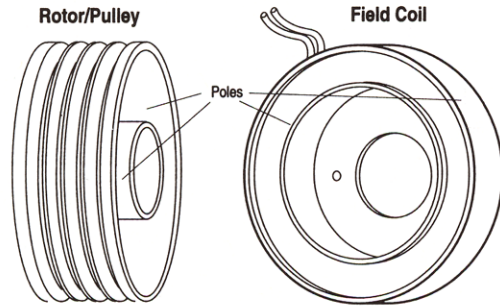

**IMPORTANT**

- The bevel on the field coil snap ring **MUST** face away from the compressor. See Figures 4A, B, C, page 5.
- The field coil snap ring must be seated fully in the groove. See Figure 4C, page 5. A typical indicator of improper field coil snap ring installation is rubbing between the field coil and rotor/pulley poles. See Fig.5 Also, if the field coil has an anti-rotation hole, the hole may be elongated or deformed from beating against the anti-rotation pin. See Figure 6.
- The lug of the field coil snap ring must **NOT** be positioned over the anti-rotation pin. See Figure 7.
- The field coil must be tight against the compressor. (Meaning the field coil cannot be rotated by hand or moved axially on the compressor).

**Figure 6**

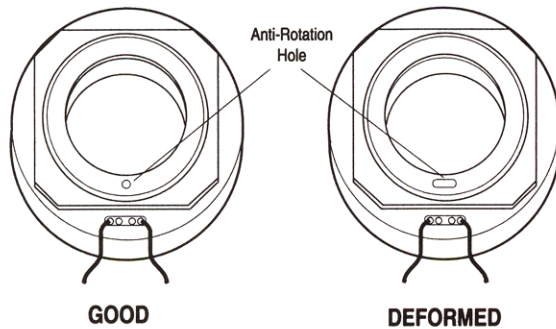

**Figure 7**

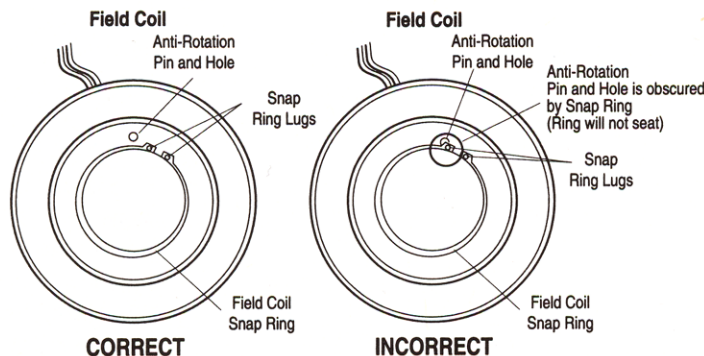

**Figure 7a**  
**Ford FX15 Compressor**

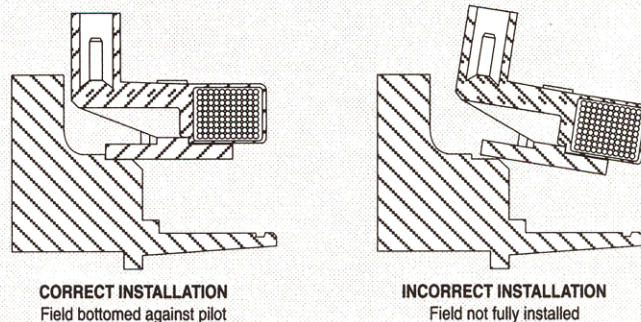

**Figure 7a**

Is field assembly installed correctly? See Figure 7a for field assembly correctly bottomed onto pilot shoulder.

- Field assembly not bottomed completely onto shoulder.
- Compressor pilot diameter is worn undersize.
- Field shell pilot diameter is worn oversize.

Use proper installation tool to bottom assembly onto shoulder. Do Not press against plastic. Replace compressor and/or field assembly.

# THE CLUTCH IS BURNED

INSPECTION	PRIMARY CAUSE(S)	CORRECTIVE ACTION
------------	------------------	-------------------

## STEP 5

Are the clutch components mismatched? See Figure 8.

**YES.** →

Straight inner pole field coil with a stepped inner pole rotor/pulley.

Replace the clutch.  
Repair or replace compressor as required.

### **IMPORTANT**

**ALWAYS** replace rotor/pulleys and hub/armatures in pairs.  
**NEVER** mix new and used rotor/pulleys and hub/armatures or clutch failure may result.

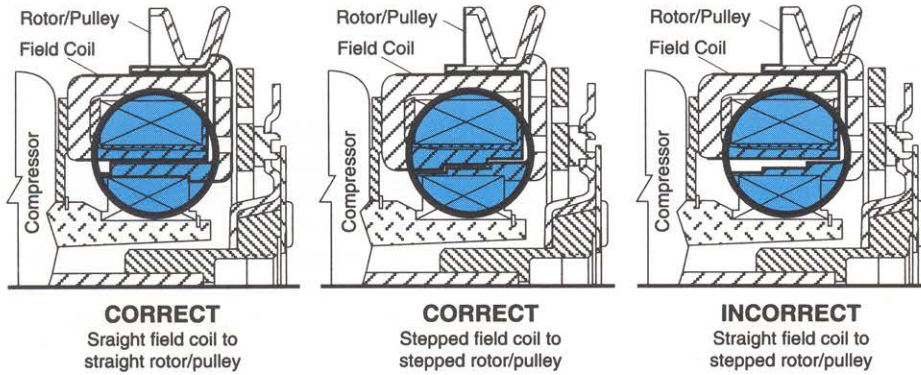

**Figure 8**

**NO.** Go to SLIPPING CLUTCH SECTION, Page 9



# THE CLUTCH IS SLIPPING

INSPECTION	PRIMARY CAUSE(S)	CORRECTIVE ACTION
------------	------------------	-------------------

## STEP 1

Is this a new clutch?

**YES.** Proceed to STEP 2.

**NO.** Proceed to STEP 3.

## STEP 2

Is the clutch damaged due to slipping?

**YES** →

Low torque due to not being burnished.

### **BURNISH PROCEDURE**

Run the clutch at 2500 to 3000 RPM. Cycle the clutch ON and OFF at a rate of 10 to 15 times per minute maximum for a total of 50 cycles minimum. This should bring the clutch up to operating torque capacity.

### **CAUTION**

**Cycle the clutch using the controls inside the car or electrical damage could result.** If slipping continues, proceed to Step 3.

**NO.** →

Low torque due to not being burnished.

Replace hub/armature and rotor/pulley and burnish as above. If slipping continues, proceed to Step 3.

## STEP 3

Is oil or grease on the clutch or on the hub/armature and rotor/pulley drive faces? See Figure 9.

Hub/Armature Drive Face

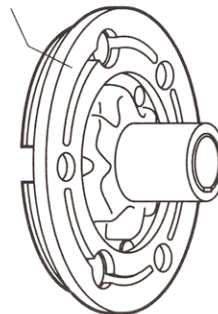

Rotor/Pulley Drive Face

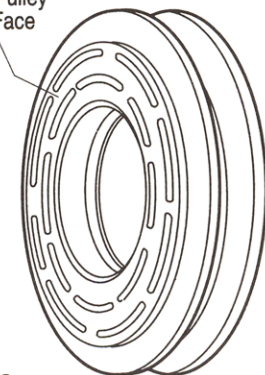

**Figure 9**

**YES.** →

**NOTE: Clutch drive faces MUST be free of ALL grease or oil.**

**NO.** Proceed to STEP 4.

- A. Compressor shaft seal leak.
- B. Compressor through-bolt leak.
- C. External oil source, such as engine oil, power steering fluid, etc.
- D. Contaminated with grease or oil during installation.

Replace clutch. Locate source of oil and/or grease and repair. Replace or repair compressor as required.

### **IMPORTANT**

**ALWAYS** replace rotor/pulleys and hub/armatures in pairs. Never mix new and used rotor/pulleys and hub/armatures or clutch failure may result.

# THE CLUTCH IS SLIPPING

INSPECTION	PRIMARY CAUSE(S)	CORRECTIVE ACTION
------------	------------------	-------------------

**STEP 4**

Are the clutch components mismatched? See Figure 10. NOTE: World Clutch field and rotors will not physically fit with the previous model field and rotor components.

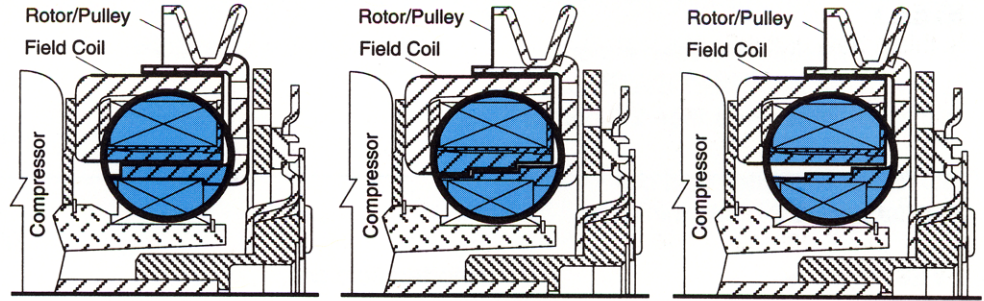

**CORRECT**  
Straight field coil to straight rotor/pulley

**CORRECT**  
Stepped field coil to stepped rotor/pulley

**INCORRECT**  
Straight field coil to stepped rotor/pulley

**Figure 10**

**YES.** →

Straight inner pole field coil with a stepped inner pole rotor/pulley.

Replace the clutch. Repair or replace compressor as required.

**IMPORTANT**

**ALWAYS** replace rotor/pulleys and hub/armatures in pairs. **NEVER** mix new and used rotor/pulleys and hub/armatures or clutch failure may result.

**NO.** Proceed to STEP 5.

**STEP 5**

Check the voltage at the field coil. All of the electrical accessories (lights, blowers, defroster, radio, windshield wipers, etc.) should be on. Is the voltage to the field coil at least 10.8 volts?

**YES.** Proceed to STEP 6.

1. Poor electrical connections.
2. Wiring less than 18 gage wire.
3. Damaged wiring, shorts.
4. Clutch relay problem (if applicable).

Diagnose electrical system and repair. See vehicle manufacturer's service manual.

**NO.** →

**STEP 6**

Check resistance of the field coil between both leads. See Figure 11. Is the resistance less than 2.0 ohms?

NOTE: World clutch field coil resistance is 3.2 ohms minimum.

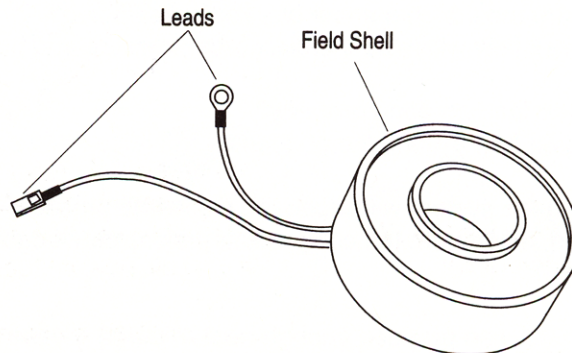

**Figure 11**

**YES.** →

Shorted field coil.

Replace field coil.

**NO.** Proceed to STEP 7  
Continued on page 11.

# THE CLUTCH IS SLIPPING

INSPECTION	PRIMARY CAUSE(S)	CORRECTIVE ACTION
<p><b>STEP 7</b> Is there continuity between either lead and the field shell? See Figure 11. Is the resistance less than 2.0 ohms?</p> <p>NOTE: World Clutch field coil resistance is 3.2 ohms minimum.</p> <p><b>YES.</b> —————&gt;</p> <p><b>NO.</b> Proceed to STEP 8.</p>	<p>Shorted field coil.</p>	<p>Replace field coil.</p>

<p><b>STEP 8</b> Remove belts. Recover refrigerant. Remove hoses and uncap fittings. Rotate the compressor shaft and check for tight spots or binding. Then compare the manufacturer's torque specifications required to rotate the compressor shaft. During rotation, does the compressor shaft bind or have tight spots or does the torque exceed the specifications?</p> <p><b>YES.</b> —————&gt;</p> <p><b>NO.</b> Proceed to STEP 9.</p>	<p>Seized or tight compressor.</p>	<p>Repair or replace the compressor.</p>
---	------------------------------------	--

**STEP 9**

The following is a list of A/C system problems that may increase system pressure which, in turn, increases the torque requirements of the clutch. Excessive system pressure may cause the clutch to slip\*.

- Does the A/C system have the correct amount of compressor oil?  
Too much oil could cause compressor slugging and a slipping clutch.  
Excess oil may accumulate in the A/C condenser, increasing system discharge pressures.  
Not enough oil may cause compressor binding, which will cause clutch slippage.
- Is the air flow around the condenser blocked or restricted?  
Inadequate air flow will raise the discharge pressure and may cause clutch slippage.
- Is the condenser fan operating properly?  
Inadequate air flow around the condenser will raise the discharge pressure and may cause clutch slippage.
- Any blockage in the system will cause the discharge pressure to increase and may cause clutch slippage.  
For example, teflon from the compressor pistons can lodge in the condenser, causing high system pressures.

\* Excessive clutch slip can produce enough heat to purge grease from the clutch bearing with resultant bearing failure. Bearing failure is usually a secondary failure cause, so further analysis is probably needed to determine the primary cause of failure.

# THE CLUTCH IS NOISY

INSPECTION	PRIMARY CAUSE(S)	CORRECTIVE ACTION
<p><b>STEP 1</b> Check for proper belt selection, tension, and alignment.</p> <p>If noise persists, proceed to STEP 2.</p>	Slipping or misaligned belt.	Refer to the vehicle manufacturer's service manual.
<p><b>STEP 2</b> Is the clutch hub/armature slipping against the rotor/pulley?</p> <p><b>YES.</b> Go to SLIPPING CLUTCH SECTION, Page 9.</p> <p><b>NO.</b> Proceed to STEP 3.</p>		

**STEP 3**  
Disconnect the field coil electrical connections and rotate the rotor/pulley. Is the hub/armature dragging on the rotor/pulley? See Figure 12

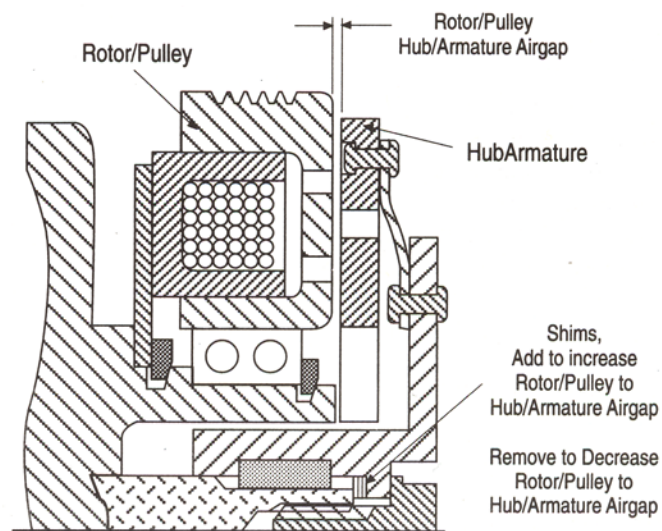

**Figure 12**

**STEP 4**  
Remove the hub/armature. Is the rotor/pulley snap ring missing or improperly installed. See Figure 13.

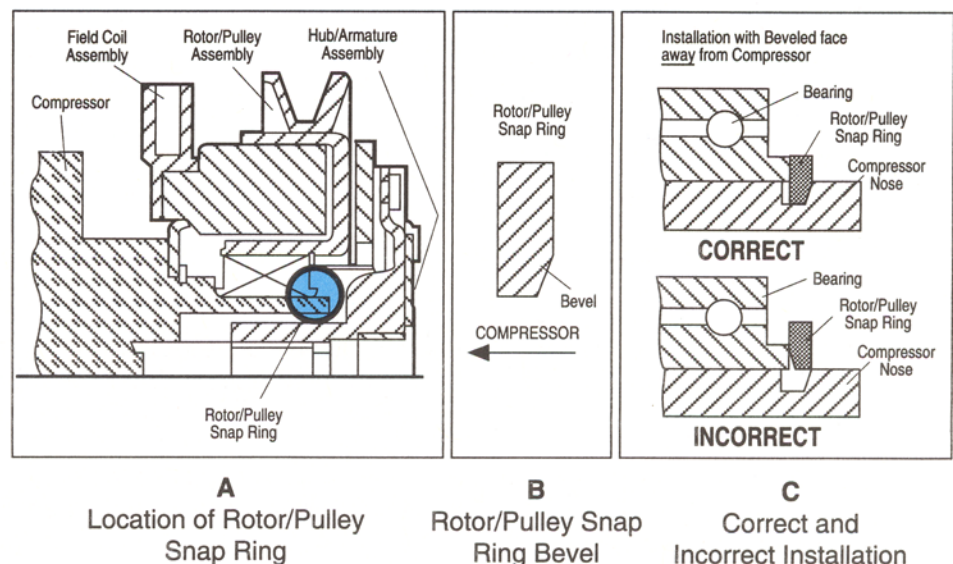

**Figure 13**

Continued on page 13.

# THE CLUTCH IS NOISY

INSPECTION	PRIMARY CAUSE(S)	CORRECTIVE ACTION
<p>YES. →</p>	<p>The rotor/pulley snap ring was not installed or was improperly installed.</p>	<p>Replace clutch if damaged. Repair or replace compressor as required.</p> <p><b>IMPORTANT</b> The bevel on the rotor/pulley snap ring <b>MUST</b> face away from the compressor. See Figures 13A, B, C.</p> <p>The rotor/pulley snap ring must be seated fully in the groove. See Figure 13C.</p>
<p>NO. →</p>	<p>Rotor/pulley to hub/armature air gap too small.</p>	<p>Reset the hub/armature to rotor/pulley air gap to 0.020 to 0.040 inch clearance by removing shims. World Clutch with Unidamp® Armature air gap settings are: New .018" to .030" and Used .013" to .025". See Figure 12. Measure the air gap between the hub/armature and rotor/pulley at three locations 120° apart using a feeler gage.</p>

## STEP 5

Is the field coil snap ring the correct ring? See Figure 14. Is it installed correctly? See Figure 15C.

### USE THE CORRECT RETAINING RING

During the 1981 model year, the field coil snap ring used to hold the field coil assembly in place was made thicker. (Ford FS-6 and Chrysler only.)

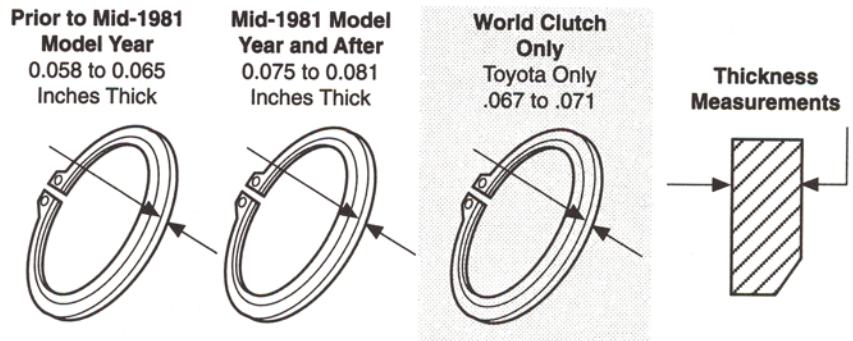
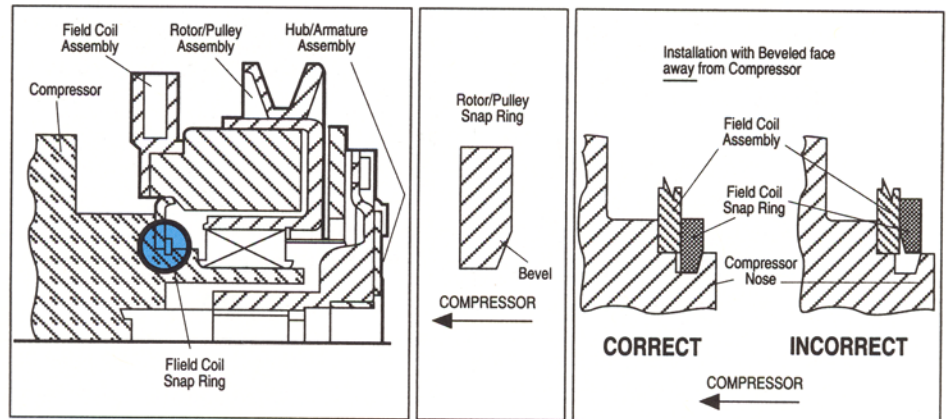

Figure 14



**A**  
Location of Rotor/Pulley Snap Ring

**B**  
Rotor/Pulley Snap Ring Bevel

**C**  
Correct and Incorrect Installation

YES. Proceed to STEP 6 (page 15).

Continued on page 15.  
Warner Electric • 800-825-9050

Figure 15

# THE CLUTCH IS NOISY

INSPECTION	PRIMARY CAUSE(S)	CORRECTIVE ACTION
------------	------------------	-------------------

NO. →

- A. Wrong field coil snap ring.
- B. Field coil snap ring installed incorrectly.

Replace clutch if damaged.  
 ⚠ Be sure to use the correct field coil snap ring. See Fig. 14, page 13.  
 Repair or replace compressor as required.

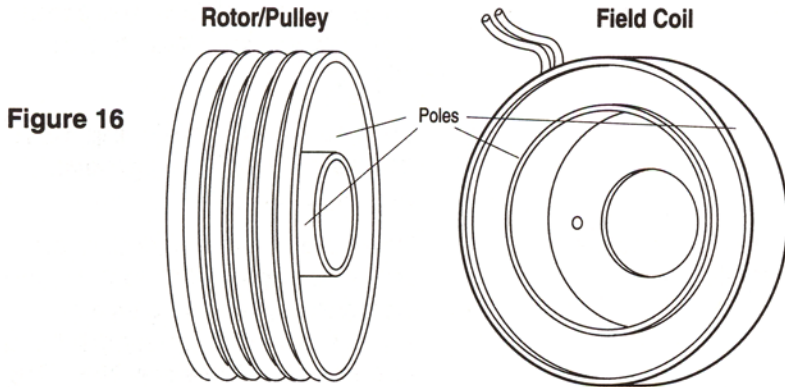

Figure 16

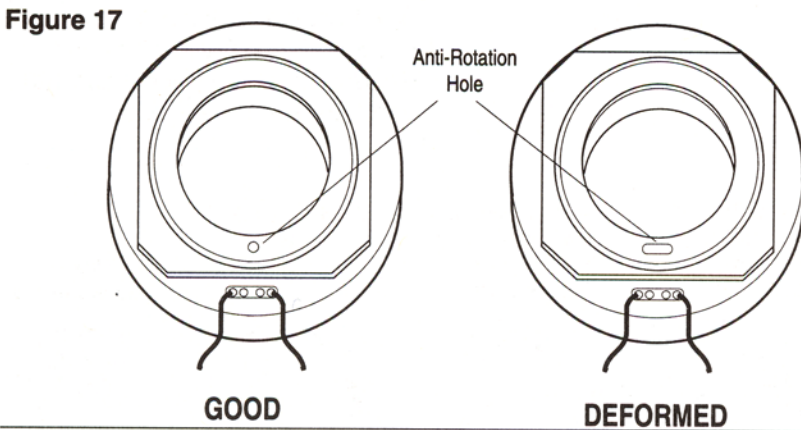
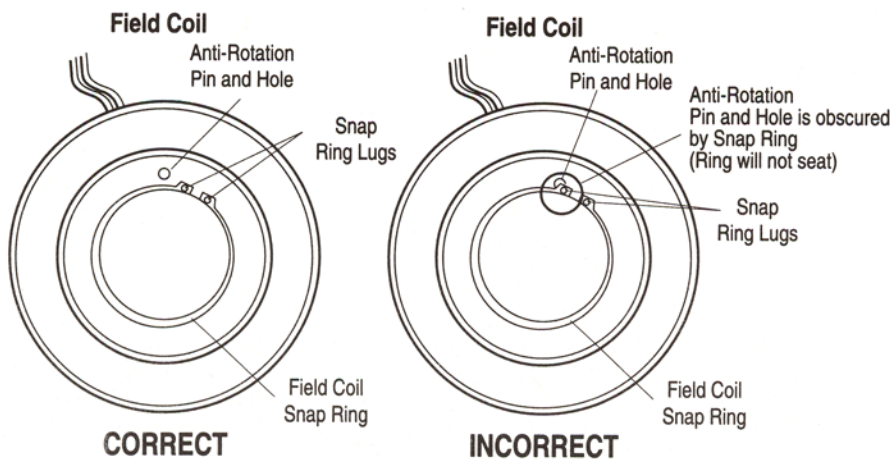

Figure 17

- IMPORTANT**
- The bevel on the field coil snap ring **MUST** face away from the compressor. See Figures 15A, B, C, page 13.
  - The field coil snap ring must be seated fully in the groove. See Figure 15C, page 13. A typical indicator of improper field coil snap ring installation is rubbing between the field coil and rotor/pulley poles. See Fig. 16
  - Also, if the field coil has an anti-rotation hole, the hole may be elongated or deformed from beating against the anti-rotation pin. See Figure 17.
  - The lug of the field coil snap ring must **NOT** be positioned over the anti-rotation pin. See Figure 18.
  - The field coil must be tight against the compressor (meaning the field coil cannot be rotated by hand or moved axially on the compressor).

Figure 18



Continued on page 15.

# THE CLUTCH IS NOISY

INSPECTION	PRIMARY CAUSE(S)	CORRECTIVE ACTION
------------	------------------	-------------------

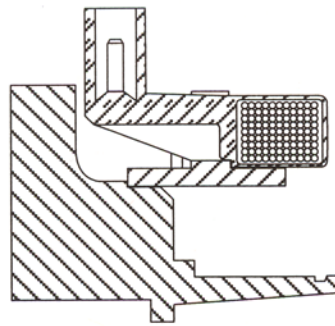

**CORRECT INSTALLATION**  
Field bottomed against pilot

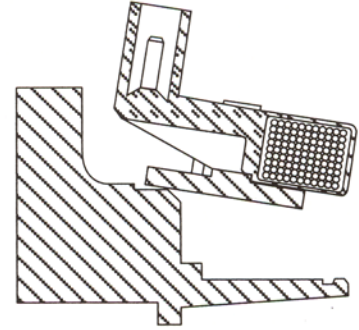

**INCORRECT INSTALLATION**  
Field not fully installed

**Figure 18a**

Is field assembly installed correctly? See Figure 18a for field assembly correctly bottomed onto pilot shoulder.

- A. Field assembly not bottomed completely onto shoulder.
- B. Compressor pilot diameter is worn undersize.
- C. Field shell pilot diameter is worn oversize.

Use proper installation tool to bottom assembly onto shoulder. Do Not press against plastic. Replace compressor and/or field assembly.

## STEP 6

Install **ONLY** the rotor/pulley assembly on the compressor and install the belts.

**⚠** Be sure to install the rotor/pulley snap ring. See Figure 19. Idle the engine and listen for noise. Does the noise continue?

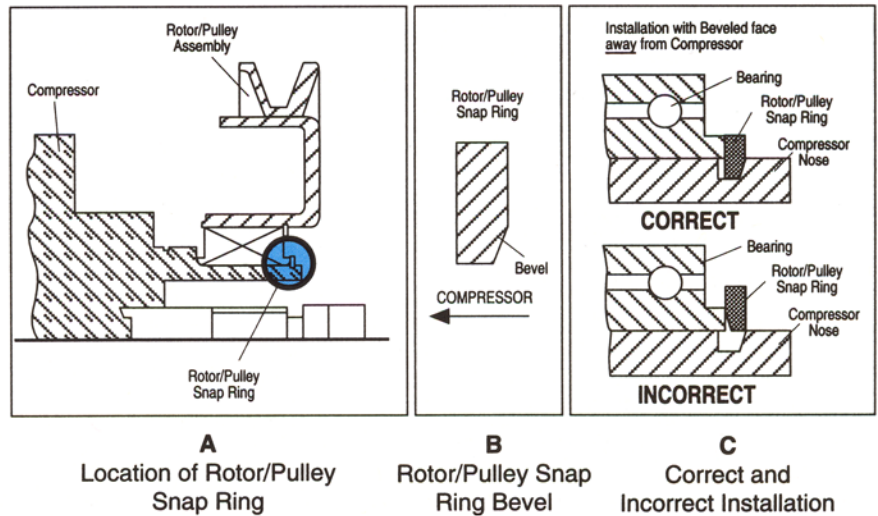

**Figure 19**

YES →

Damaged bearing.

Replace clutch.

## IMPORTANT

**⚠** Do not attempt to replace the bearing in the rotor/pulley.

# THE CLUTCH FAILS TO ENGAGE

INSPECTION	PRIMARY CAUSE(S)	CORRECTIVE ACTION
------------	------------------	-------------------

## STEP 1

Check the hub/armature to rotor/pulley air gap. Does it exceed 0.125 inches? See Figure 20.

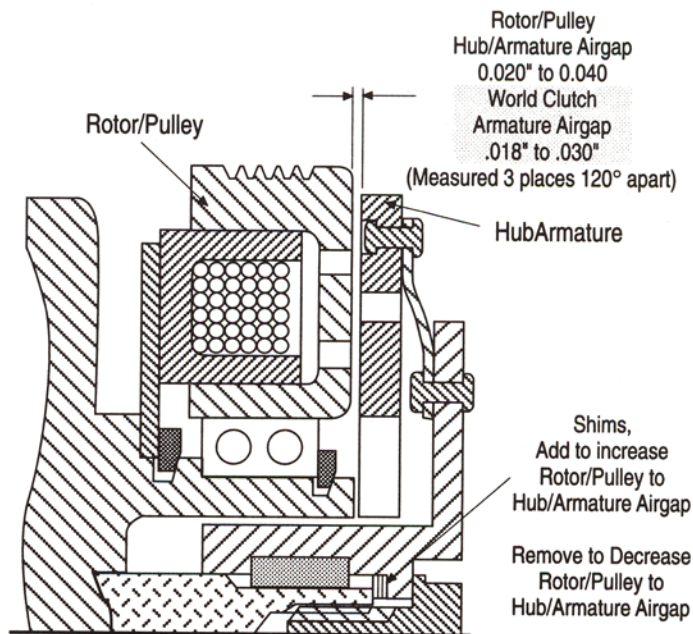

Figure 20

**YES.** →

Air gap excessive.

Reset the hub/armature to rotor/pulley air gap to 0.020 to 0.040 inch clearance by removing shims. World Clutch with Unidamp® Armature airgap settings are New .018" to .030" or Used .013" to .025". See Figure 18. Measure the air gap between the hub/armature and rotor/pulley at three locations 120° apart using a feeler gauge.

**NO.** proceed to STEP 2.

If clutch fails to engage, proceed to Step 2.

## STEP 2

Disconnect the electrical connections to the field coil. Check the voltage available to the field coil. All of the electrical accessories (lights, blowers, defroster, radio, windshield wipers, etc.) should be on. Is the voltage to the field coil at least 10.8 volts?

**NO.** →

1. Poor electrical connections.
2. Wiring less than 18 gage.
3. Damaged wiring, shorts.
4. Clutch relay problem (if applicable).
5. Vehicle charging system not operating properly.

Diagnose electrical system and repair. See vehicle manufacturer's service manual.

**YES.** Proceed to STEP 3.

Continued on page 17.



# THE CLUTCH FAILS TO ENGAGE

INSPECTION	PRIMARY CAUSE(S)	CORRECTIVE ACTION
------------	------------------	-------------------

## STEP 3

Check resistance of the field coil between both leads. See Figure 21. Is the resistance less than 2.0 ohms (or 3.2 ohms for a World Clutch field coil)?

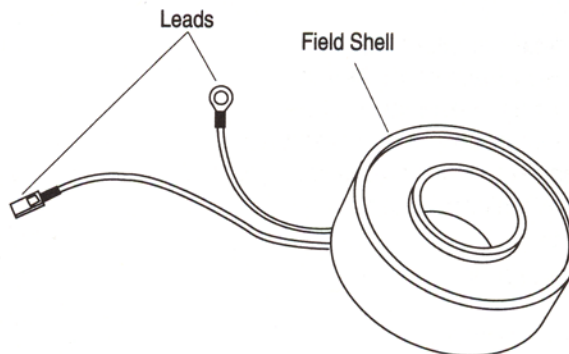

**Figure 21**

**YES** →

Shorted field coil.

Replace field coil.

**NO.** Proceed to STEP 4

## STEP 4

Is there continuity between either lead and the field shell? See Figure 21.

**YES** →

Shorted field coil.

Replace feild coil.

## STEP 5

Is there continuity between the field coil leads? See Figure 21.

**YES** →

Faulty electrical system.

Diagnose electrical system and repair. See vehicle manufacturer's service manual.

**NO** →

Open field coil.

Replace field coil.

Continued on page 18.

# THE CLUTCH FAILS TO DISENGAGE

INSPECTION	PRIMARY CAUSE(S)	CORRECTIVE ACTION
------------	------------------	-------------------

## STEP 1

Disconnect the field coil electrical connections. Check the rotor/pulley to hub/armature air gap. See Figure 22. Is there a minimum of 0.020 inch clearance between the hub/armature and the rotor/pulley? World Clutch with Unidamp® armature has .010" minimum airgap.

**YES.** Proceed to STEP 3.

**NO.** Proceed to STEP 2.

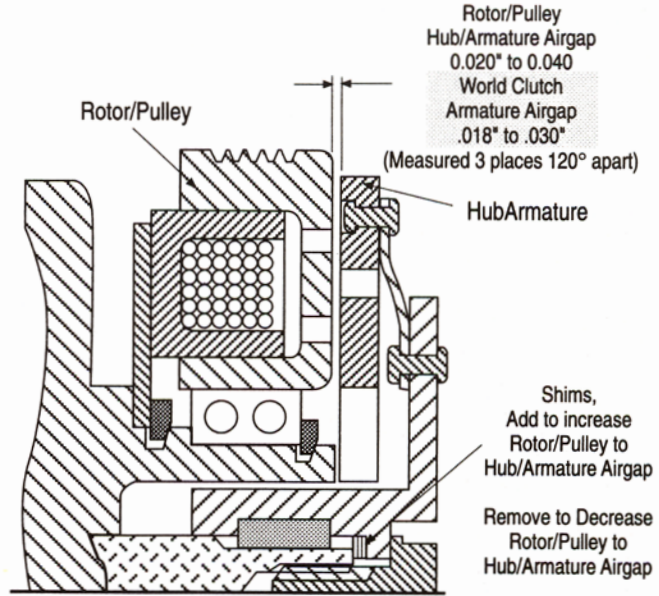

Figure 22

## STEP 2

Remove the hub/armature. Is the rotor/pulley snap ring missing or improperly installed? See Figures 23.

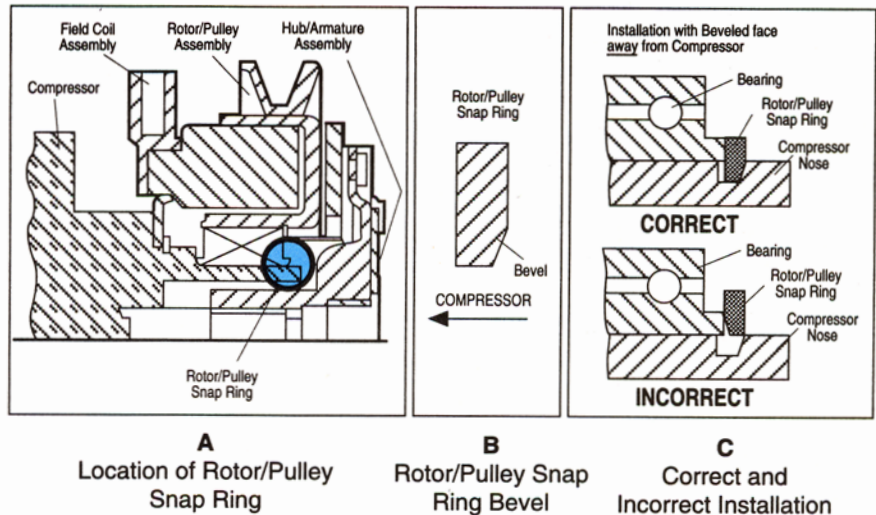

Figure 23

**YES.** →

The rotor/pulley snap ring was not installed or was improperly installed.

Replace the clutch if damaged. Repair or replace compressor as required.

### IMPORTANT

- The bevel on the rotor/pulley snap ring **MUST** face away from the compressor. See Figures 23.
- The rotor/pulley snap ring must be seated fully in the groove. See Figure 23C.
- World Clutch with Unidamp® armature average airgap setting is:  
New: .018" to .030"  
Used: .013" to .025"

# THE CLUTCH FAILS TO DISENGAGE

INSPECTION	PRIMARY CAUSE(S)	CORRECTIVE ACTION
NO. —————>	The hub/armature to rotor/pulley air gap is too small.	Reinstall the armature and set the hub/armature to rotor/pulley air gap to 0.020 to 0.040 inch clearance by adding shims. World Clutch with Unidamp armature airgap settings are New .018" to .030" and Used .013 .025". See Figure 22. Measure the air gap between the hub/armature and rotor/pulley at three locations 120° apart using a feeler gauge.

## STEP 3

Connect field coil terminals. Does the clutch engage without turning on the A/C?

YES. —————>

Electrical problem.

Diagnose electrical system and repair. See vehicle manufacturer's service manual.







[www.warnerelectric.com](http://www.warnerelectric.com)

31 Industrial Park Road  
New Hartford, CT 06057  
815-389-3771  
Fax: 815-389-2582

An **Altra Industrial Motion** Company

