

# Selection Guide

## Application Factors

Determine the best Wichita clutch or brake for your application by making a preliminary product selection.

1. Decide which of the four possible functions you wish to perform.
2. Choose the mounting arrangement best suited to your application.
3. In the Function/Mounting chart below, choose the proper type of mounting (1,2,3, etc.)
4. Consult your Wichita representative for final product selection.

Wichita Product	Page No.	Function/Mounting Condition				
		Controlled Acceleration Provide smooth acceleration of a load.	Cycling Accurately positions a load in a repeatable fashion.	Controlled Deceleration Provides a smooth, cushioned deceleration of a load.	Controlled Slip Provide continuous tension to a web or strand.	
					High Heat	Low Heat
Drum Clutch/Brake	78	1, 2	1, 2	1, 2, 3		1, 2
Very Low Inertia Clutch or Brake	12	1, 2	1, 2	1, 2, 3		1, 2, 3
Low Inertia Clutch or Brake	12	1, 2	1, 2	1, 2, 3		1, 2
High Torque Clutch	30		1	1		1
Spring-Set Air Release Brake	38		1, 2, 3	1, 2, 3		
CSM (Kopper Kool) Clutch or Brake	64	1, 2, 3	1, 2, 3	1, 2, 3	1, 2, 3	
Mistral II Brake (Tension Brakes)	46					2
ModEvo (Tension Brakes)	48					2, 3
AquaMaKKs Clutches and Brakes (Water Cooled)	82			2, 5		
Standard Vent Coupling Clutch	50	3, 4				
Standard Vent Grinding Mill Clutch	50	3, 4				
Oil Immersed and Dry HC	60	3, 4		3, 4		

## Types of Mounting (see page 7)

- |                         |                                      |
|-------------------------|--------------------------------------|
| <b>1</b> Indirect Mount | <b>4</b> Shaft-to-Shaft              |
| <b>2</b> Direct Mount   | <b>5</b> Brake Mount Electric        |
| <b>3</b> Through Shaft  | <b>6</b> Clutch or Brake Mount Press |

## Types of mounting

**1** Indirect Mount

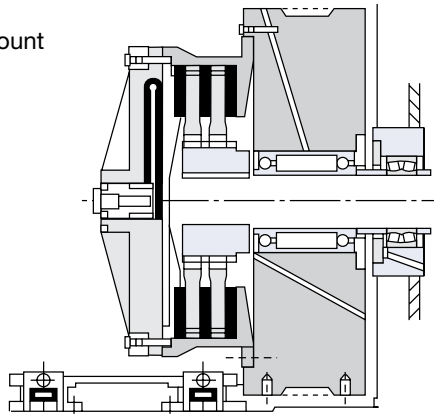

**2** Direct Mount

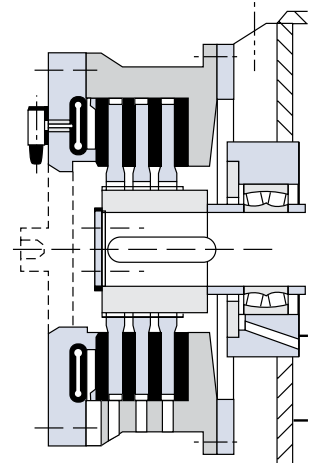

**3** Through Shaft, Inboard Mount Clutch

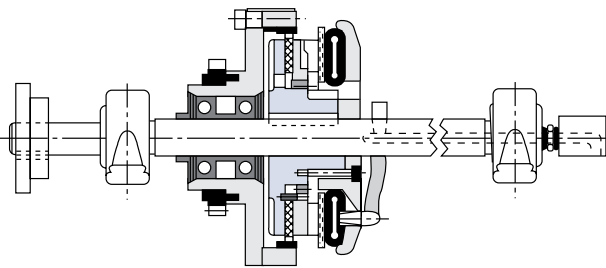

**4** Shaft-to-Shaft In-line (clutch-coupling)

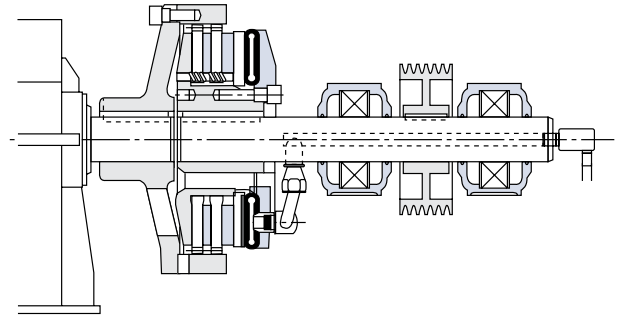

**5** Electric Motor C-Face or Foot Mount Brake

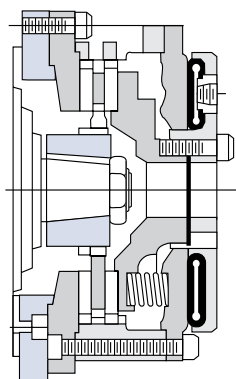

**6** Typical Wichita Clutch and Brake Mounting on a Press

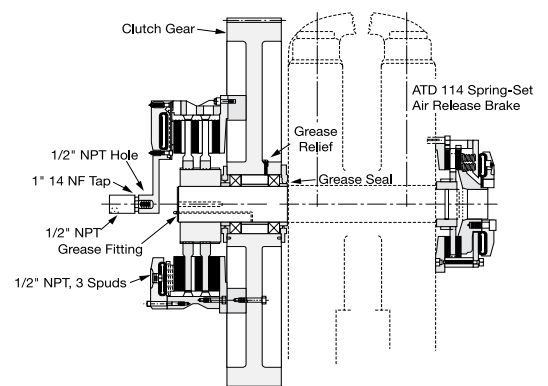

# Selection Guide

## Application Factors

Clutch/Brake sizes are affected by the following variables:

1. Machines that operate under smooth loads require smaller clutch/brakes. These machines are driven by either multi-cylinder high speed engines or electric motors with reduced starting current.
2. Drives that require high starting current motors will require clutch/brakes with sufficient torque to prevent excessive slipping while starting.
3. Starting torque may be high, which requires a fast clutch/brake response time to transmit the required torque; or, extended clutch/brake slip time is required to protect the prime mover.
4. Starting torques may be very low compared to the normal torque which may result in the clutch/brake not being fully pressurized prior to the time of torque requirement. This will cause the clutch/brake to overheat from slippage. Clutch/brake inflation time in this instance is very important.
5. Clutch/brakes on most machines are designed to slip prior to damage from shock loads. As a result, the clutch/brake may require periodic maintenance; therefore the clutch/brake should be located in the power train for easy access. Clutch/brakes should also be located for maximum cooling air. In instances where this is not possible, forced air cooling may be desirable to extend clutch/brake life.
6. Safe operating speeds for clutch/brakes should be maintained in design. The following material specifications are recommended for safe operation. The maximum speeds shown are safe operating speeds based upon years of Wichita experience. Consult Wichita for higher speed versions.

### Maximum Clutch/Brake

Contact Velocity m/sec	Material
30m/sec (Recommended upper limit for slip) . . . . .	cast iron
45m/sec. . . . .	ductile iron
60m/sec. . . . .	steel

Dynamic balancing recommended when peripheral speeds exceed 18 m/sec. These velocities are measured at the nominal outside diameter of the clutch/brake plate.

Field of Application	Machine or Equipment	Wichita Product												
		Drum C/B	Air Tube Disc Clutches & Brakes				CSM (KK)	Tension Brakes		Spring-Set Motor Brakes	Standard Vent Clutches		Oil Immersed and Dry HC	AquaMakKs
			Very Low Inertia	Low Inertia	High Torque	Spring-Set		Mistral II	ModEvo		Coupling	Ball Mill		
Air Movement Pumps	Centrifugal compressors	•		•	•						•			
	Reciprocating compressors (over 2 cylinders)	•		•	•						•			
	Reciprocating compressors (1 or 2 cylinders)	•		•	•						•			
	Centrifugal fans Blowers	•		•	•						•			
Agitators	Liquid Semi-solid Solids	•		•	•						•			
Brick manufacturing	Brick press	•	•	•		•					•			
	Extruder Pug mill	•		•	•						•			
Canning & bottling machine	Bottle-can feeders	•	•	•	•									
	Filling Mixers	•		•	•						•			

Field of Application	Machine or Equipment	Wichita Product												
		Drum C/B	Air Tube Disc Clutches & Brakes				CSM (KK)	Tension Brakes		Spring-Set Motor Brakes	Standard Vent Clutches		Oil Immersed and Dry HC	AquaMakks
			Very Low Inertia	Low Inertia	High Torque	Spring-Set		Mistral II	ModEvo		Coupling	Ball Mill		
Engine driven equipment	Crane	•		•		•			•	•			•	
	Hoist	•		•		•				•			•	
	Engine											•		
	Crowd	•		•						•				
Grinding mills	Ball-rod-sag-pebble											•		
	Crushers											•		
	Shakers											•		
Lumber processing	Yarder	•	•	•	•	•								
	Carriages, conveyers Chipper, logger	•	•	•	•	•								
Marine	Propulsion clutch CP wheel	•		•								•	•	
	Shaft brakes	•		•								•	•	
	Propulsion reversing type	•		•								•	•	
	Anchor winch	•		•		•						•	•	
Bulk material handling	Conveyors evenly loaded	•		•	•	•						•		
	Line shaft evenly loaded	•		•	•	•						•		
	Feeders	•		•	•	•						•		
	Elevators	•		•	•	•						•		
Metal production & metalforming	Coilers	•	•	•		•						•		
	Slitters	•	•	•	•	•						•		
	Press brake	•	•	•	•	•						•		
	Non-gearred press	•	•	•	•	•						•		
	Geared press	•	•	•	•	•						•		
	Draw bench	•	•	•		•						•		
	Rolling mill	•	•	•								•		
	Shear	•	•	•	•	•						•		
	Back geared press	•	•	•	•	•						•		
	Hammer Mill	•		•		•			•					
Forging	•		•		•						•			
Paper industry dryer sections & calenders, consult factory	Fourdrinier to 500 FPM													
	Fourdrinier to 1800 RPM													
	Paper mill plane	•		•		•		•	•			•		
	Smoothing press													
	Press selections													
	Dryers Calenders													
Petroleum production	Drilling & service rig	•		•		•						•	•	
	Master clutches	•		•								•		
	Compound clutches	•		•								•		
	Rotary Drum	•		•								•		
	Mud pumps	•										•	•	
	PTO clutches											•	•	
Rubber manufacturing	Transfer machines evenly loaded													
	Banberry mixer													
	Drum mixer	•		•								•		
	Extruder													
	Calender													
	Centrifuge													