

ERS VAR 15 for the Elevator Market



Elevator Applications

- Gearless Motors

ELECTRICALLY RELEASED BRAKE FOR ELEVATORS

Electrically Released Safety Brake

The ERS VAR 15, an electrically released safety brake with fixed magnets and a floating friction disc, is a highly modular braking system for gearless motors.

- Redundant system in accordance with EN 81-20/50 when two or more magnets are used
- Complies with Directive 2014/33/EU
- Compact and modular design: From 2 up to 4 magnets in standard configuration
- Torque Capacity in accordance with diameter of friction disc and number of magnets
- Available with optional hand release
- Low noise operation through the life of the brake
- Very easy installation
- Install directly on the drive housing or additional flange
- Micro switch equipped
- Nearly maintenance free (further information in our service manual)
- Overexcitation (dual voltage) or single voltage

www.warnerelectric.com

 **Warner Electric**[®]
Altra Industrial Motion

ERS VAR 15

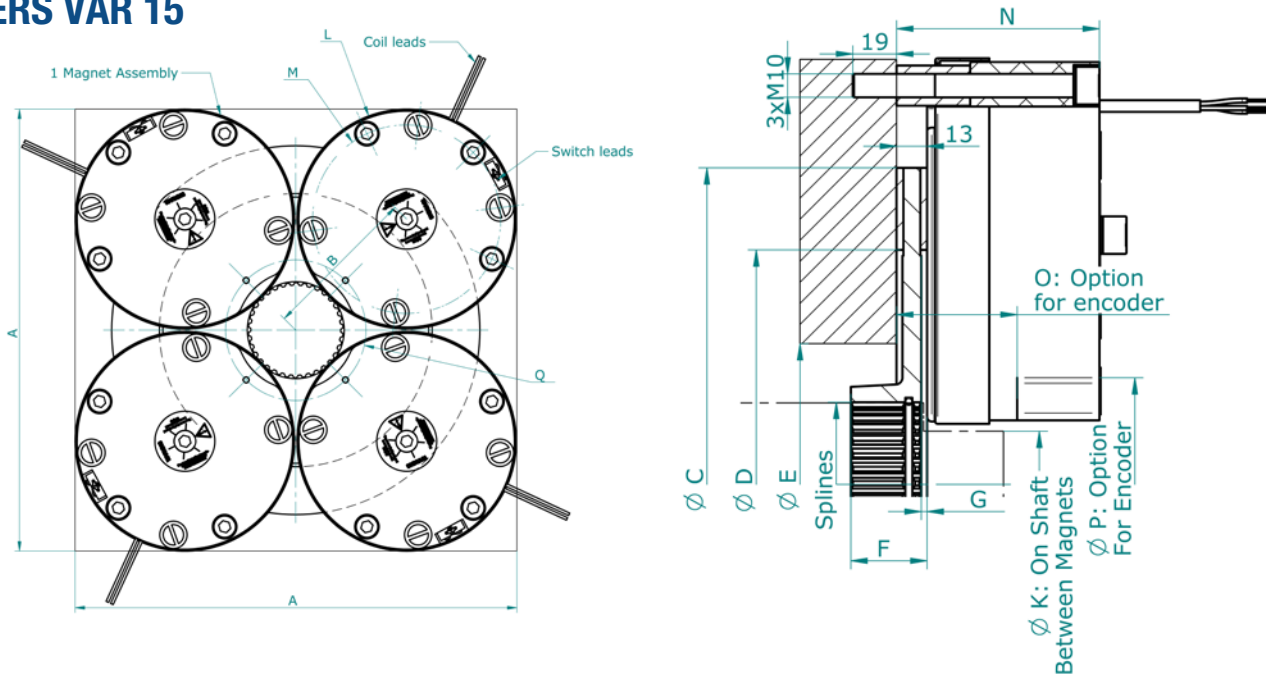

Characteristics for 1 Magnet Assembly

Size		ERS VAR15-02				ERS VAR15-11			
Friction Disc Ø	mm	237	270	237	270	237	270	237	270
Standard Torque Per Magnet	Nm	250	320	300	350	300**	400**	350	500
Cert. Max. Speed	m/s	6.5	3.25	6.5	3.25	6.15	3.69	6.15	3.69
Cert. Max. Speed	rpm	600	300	500	250	500	300	500	300
A	mm	290	305			292		324	
B	mm	103	112			93		115	
C	mm	237	270			237		270	
D	mm	177	200			177		200	
E _{min}	mm	100	100			100		100	
F	mm	30	30			30		30	
G	mm	3	3			3		3	
K	mm	59	78			25		69	
L Nominal	mm		143					161	
M	mm		124					138	
N	mm	101	101			86		86	
O (*)	mm	40	40			51		51	
P (*)	mm	83	105			50		90	
Q (*)	-	90	108			59		103	
Hand Release	-							Option	
Weight	Kg		10					11	

(*) Option For Encoder

(**) 2 Magnets Maximum

Voltage (VDC)

With Overexcitation	
Holding Voltage	Overexcitation Voltage
103.5	207
Without Overexcitation	
Single Voltage	
207	
103.5	
24	

Tolerances on the supply voltage at the brake terminals +5% / -10% (NF C 79-300).