

3

Bauer	
D-73446 Esslingen A1 1711M0816 49/2008	
Type: BG70-11DXE13LA4C2	
Ex II 2 G Ex e II T3	
PTR 08 ATEX 3052-BL02	
60 Hz	0.301 kW
400 V	11.9 A
1460 rpm	1810 rpm
8.1	12.0
IP 65	IP 23
1	40
CE 0102 EN 60034	

Page

19-28

Type Designations

Significance of type designation

BG-series helical-geared motor

BF-series shaft-mounted geared motor

BK-series bevel-geared motor

BS-series worm-geared motor

Description of the Designs

General Description

Type Designations

Significance of type designation

Bauer bevel-gear motor with brake and standard add-ons

Example: Bauer bevel-gear motor with brake and standard add-ons

Significance of type designation

The type designation of a BAUER geared motor is a code designating all the features in the drive configuration.

The build-up of the type designation is explained with the help of the following example of a bevel geared motor with brake and series options.

3

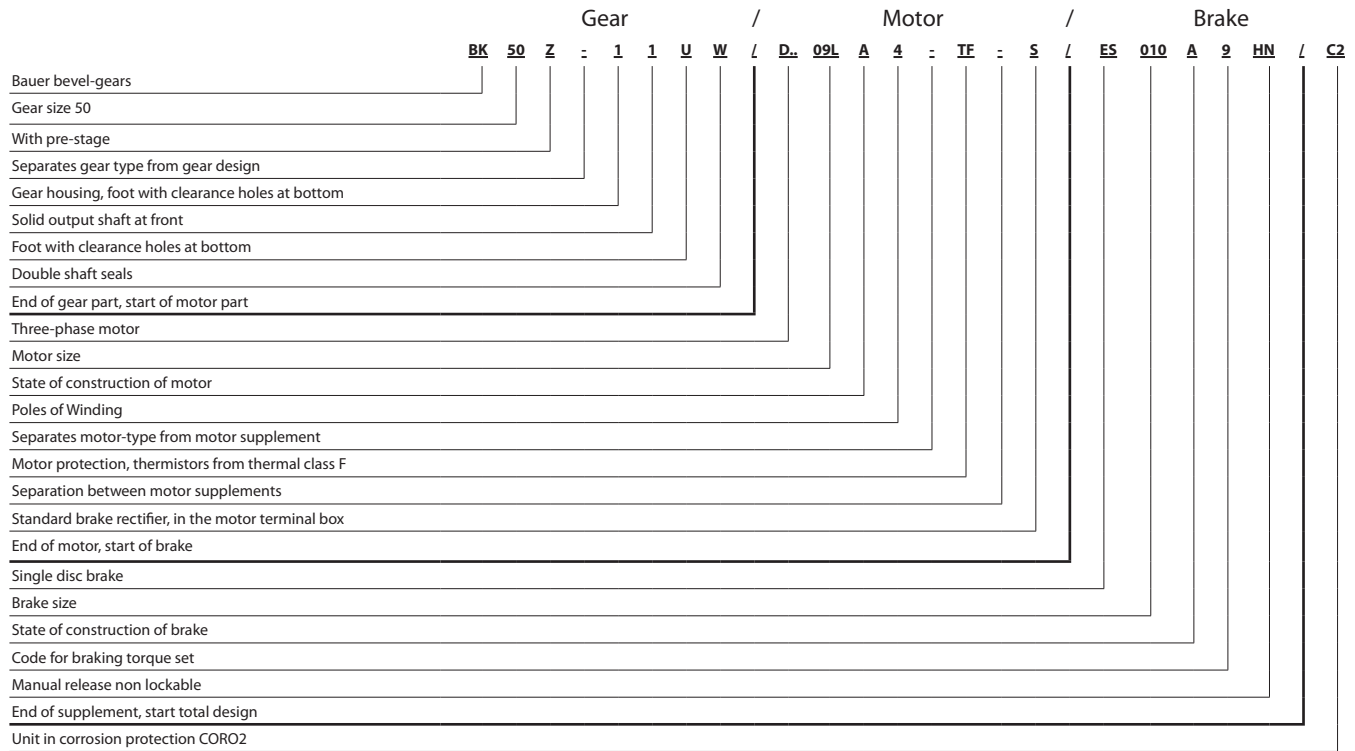

Type Designations

BG-series helical-geared motor

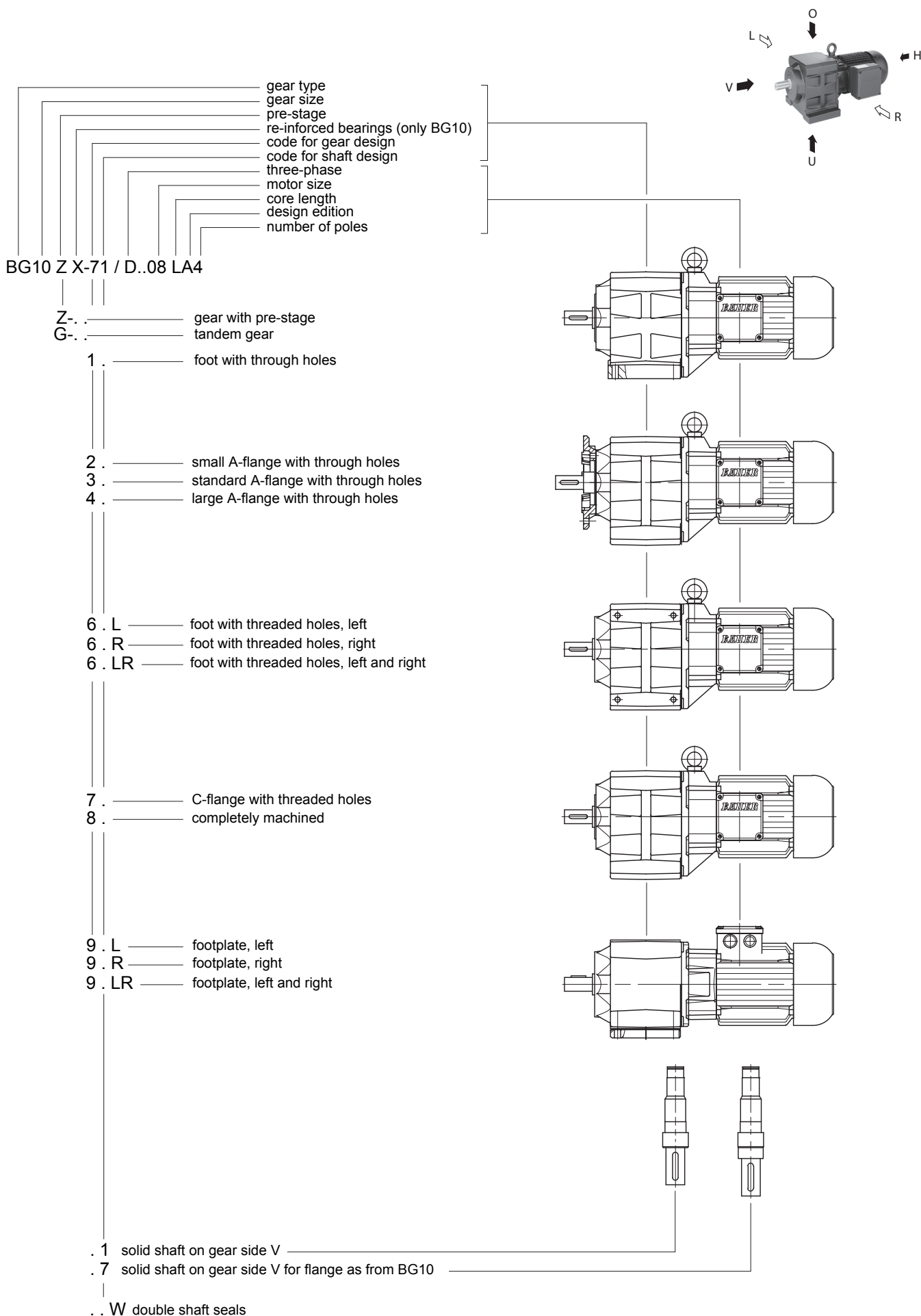

Type Designations

BF-series shaft-mounted geared motor

3

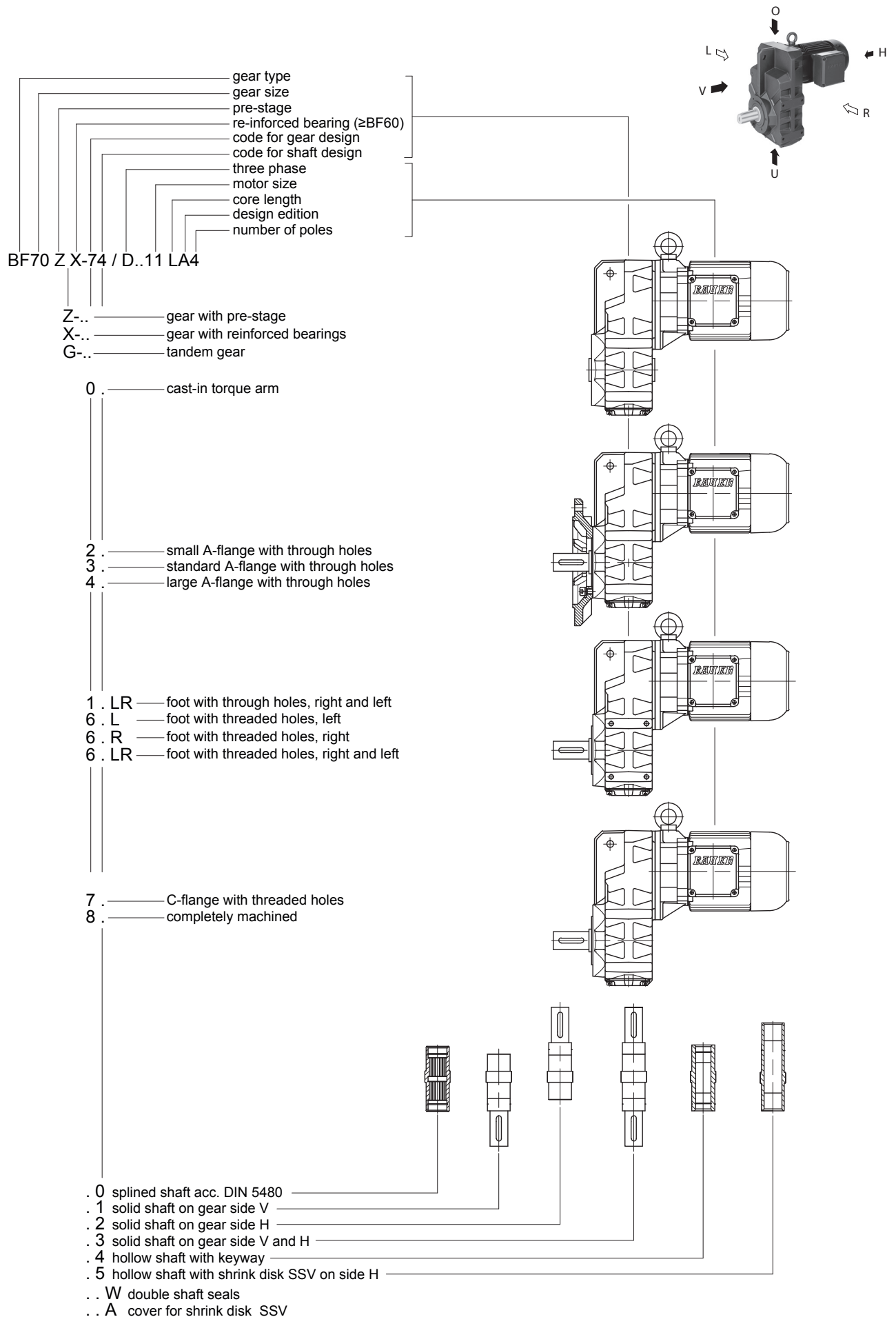

Type Designations

BK-series bevel-gear motor

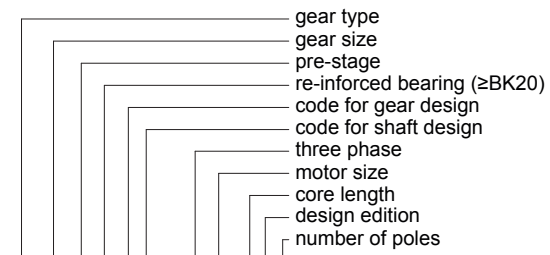

BK20 Z X-64U / D06 LA4

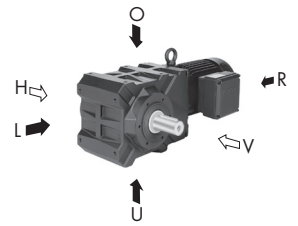

- 1 . U ——— foot with through holes, bottom
- 1 . L ——— foot with through holes, left
- 1 . O ——— foot with through holes, top

- 2 . V ——— small A-flange with through holes, front
- 3 . V ——— standard A-flange with through holes, front
- 4 . V ——— large A-flange with through holes, front
- . . H ——— A-flange, rear
- . . VH ——— A-flange, front and rear

- 5 . V ——— torque arm, front
- 5 . VL ——— torque arm, front to left
- 5 . VO ——— torque arm, front to top
- 5 . VU ——— torque arm, front to bottom
- 5 . HL ——— torque arm, rear to left
- 5 . HO ——— torque arm, rear to top
- 5 . HU ——— torque arm, rear to bottom

- 6 . U ——— foot with threaded holes, bottom
- 6 . L ——— foot with threaded holes, left
- 6 . O ——— foot with threaded holes, top

- 7 . V ——— C-flange with threaded holes, front
- 7 . H ——— C-flange with threaded holes, rear
- 7 . VH ——— C-flange with threaded holes, front and rear
- 8 . ——— completely machined

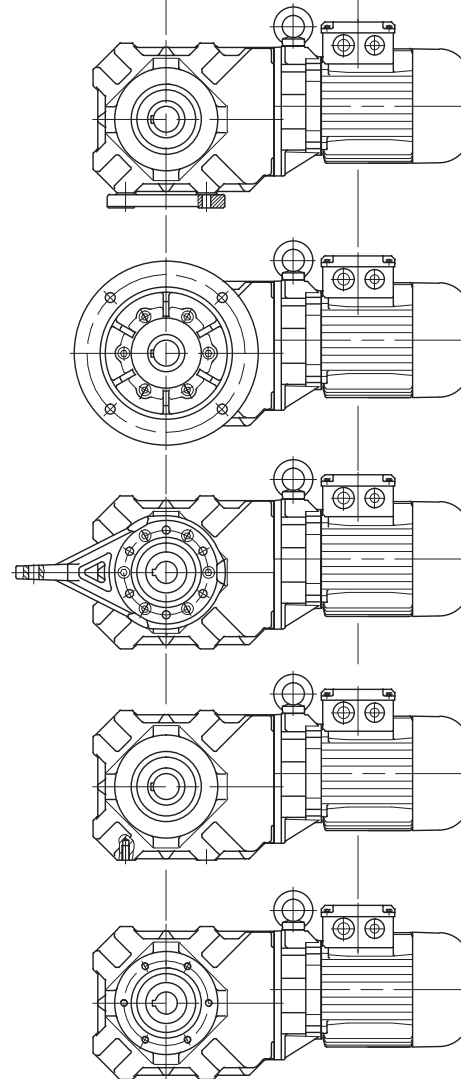

- . 0 Splined shaft acc. DIN 5480
- . 1 solid shaft on gear side V
- . 2 solid shaft on gear side H
- . 3 solid shaft on gear side V and H
- . 4 hollow shaft with keyway
- . 5 hollow shaft with shrink disk SSV on gear side H
- . . W double shaft seals
- . . A cover for shrink disk SSV

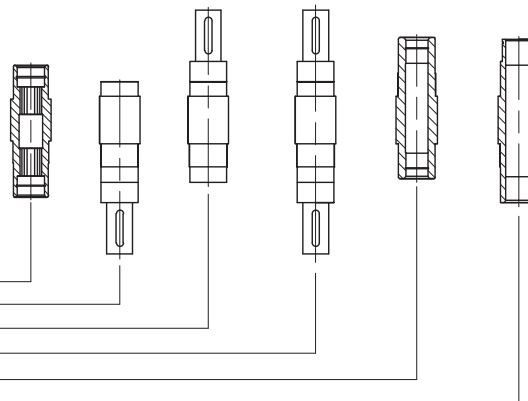

Type Designations

BS-series worm-geared motor

3

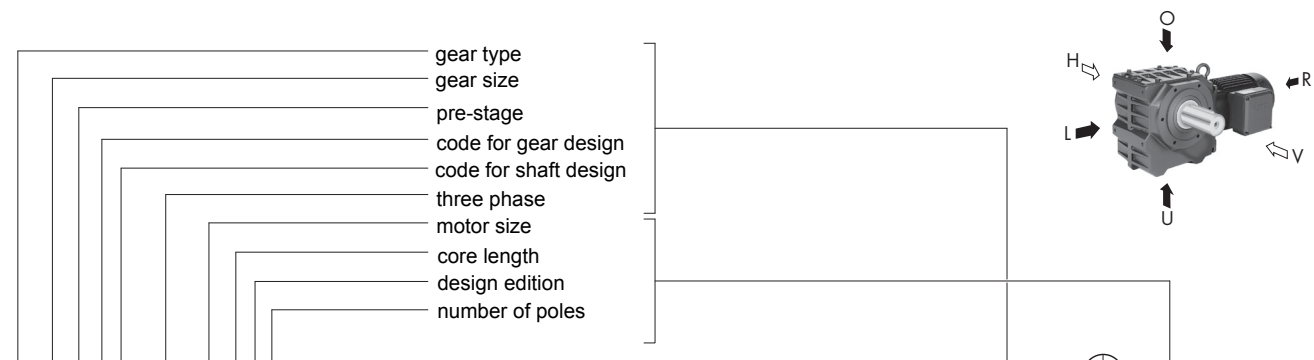

BS40 Z-64U/ D..08 LA4

- 1 . U ————— foot with through holes, bottom
- 1 . L ————— foot with through holes, left
- 1 . O ————— foot with through holes, top

- 2 . V ————— small A-Flange with through holes, front
- 3 . V ————— standard A-Flange with through holes, front
- 4 . V ————— large A-Flange with through holes, front
- .. H ————— A-flange, rear (standard flange)
- .. VH ————— A-flange, front and rear (standard flange)

- 5 . V ————— torque arm, front
- 5 . VL ————— torque arm, front to left
- 5 . VO ————— torque arm, front to top
- 5 . VU ————— torque arm, front to bottom
- 5 . HL ————— torque arm, rear to left
- 5 . HO ————— torque arm, rear to top
- 5 . HU ————— torque arm, rear to bottom

- 6 . U ————— foot with threaded holes, bottom
- 6 . L ————— foot with threaded holes, left
- 6 . O ————— foot with threaded holes, top

- 7 . V ————— C-flange with threaded holes, front
- 7 . H ————— C-flange with threaded holes, rear
- 7 . VH ————— C-flange with threaded holes, front and rear
- 8 . ————— completely machined

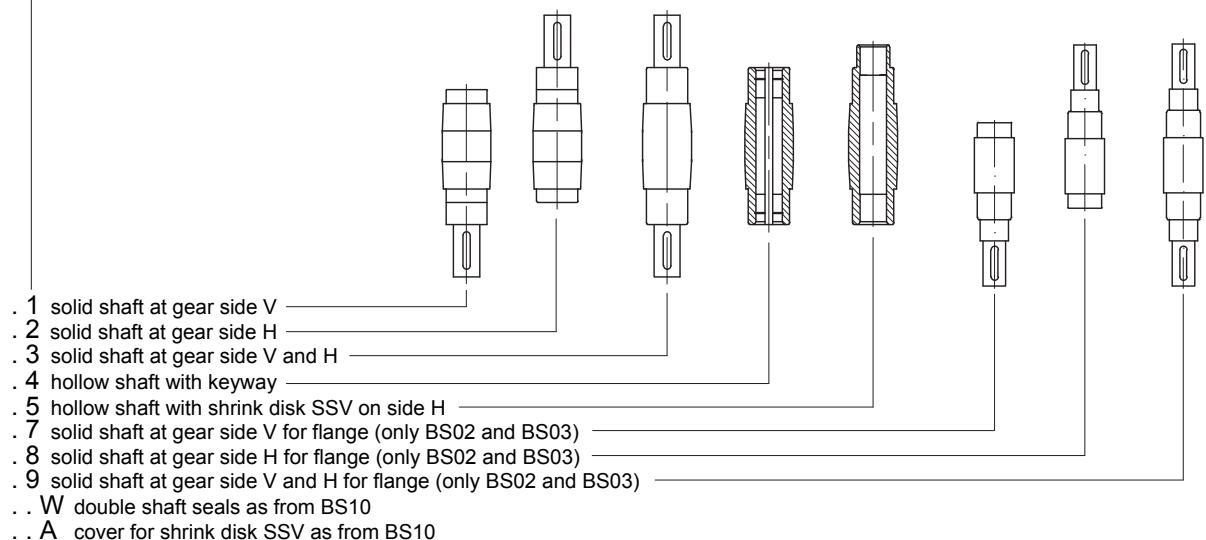
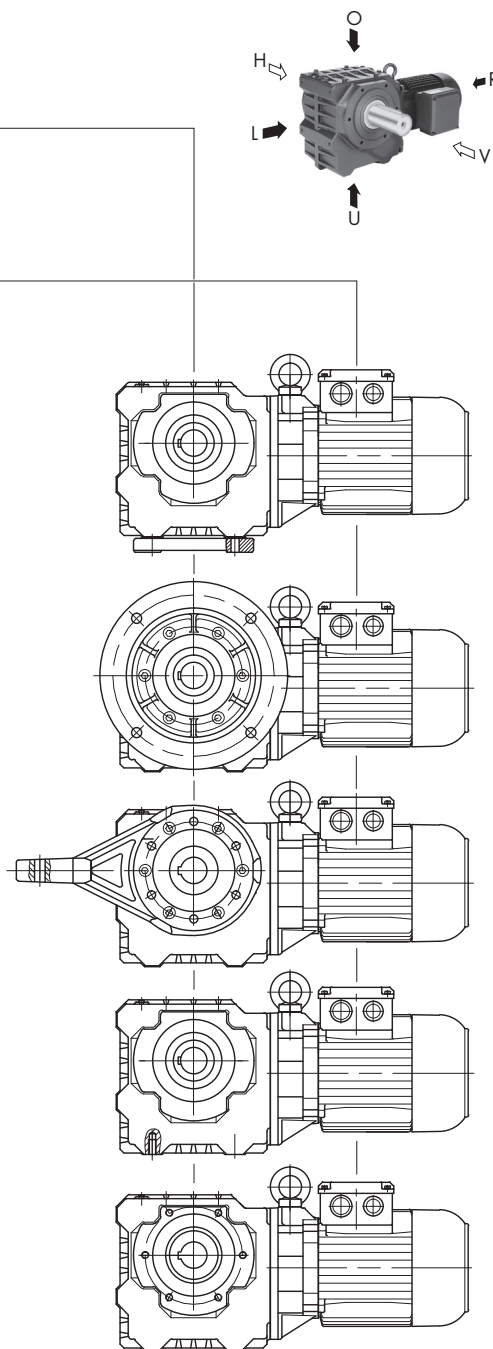

- . 1 solid shaft at gear side V
- . 2 solid shaft at gear side H
- . 3 solid shaft at gear side V and H
- . 4 hollow shaft with keyway
- . 5 hollow shaft with shrink disk SSV on side H
- . 7 solid shaft at gear side V for flange (only BS02 and BS03)
- . 8 solid shaft at gear side H for flange (only BS02 and BS03)
- . 9 solid shaft at gear side V and H for flange (only BS02 and BS03)
- .. W double shaft seals as from BS10
- .. A cover for shrink disk SSV as from BS10

BG and BF series

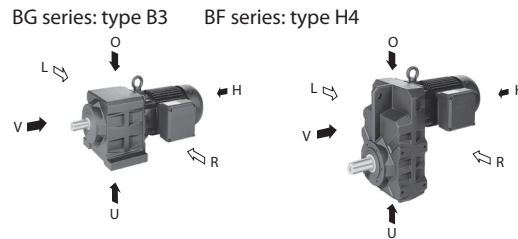

- V = Front
The side of the gear unit facing away from the motor or the source of motive power
- H = Rear
The side of the gear unit facing toward the motor or the source of motive power
- L = Left
The left side of the gear unit as viewed from the output shaft side of type B3 for the BG series or type H4 for the BF series
- R = Right
The right side of the gear unit as viewed from the output shaft side of type B3 for the BG series or type H4 for the BF series

BK and BS series

BK series: type H1 BS series: type H1

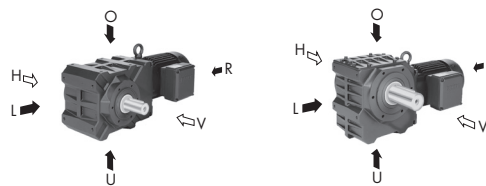

- V = Front
The side of the gear unit facing toward the viewer looking toward the type H1 unit
- H = Rear
The side of the gear unit facing away from the viewer looking toward the type H1 unit
- L = Links
The left side of the gear unit as viewed from the output shaft side of type H1, or the torque brace oriented to the left
- O = Top
The top side of the gear unit as viewed from the output shaft side of type H1, or the torque brace oriented upwards
- U = Bottom
The bottom side of the gear unit as viewed from the output shaft side of type H1, or the torque brace oriented downwards

Type Designations

General construction

3

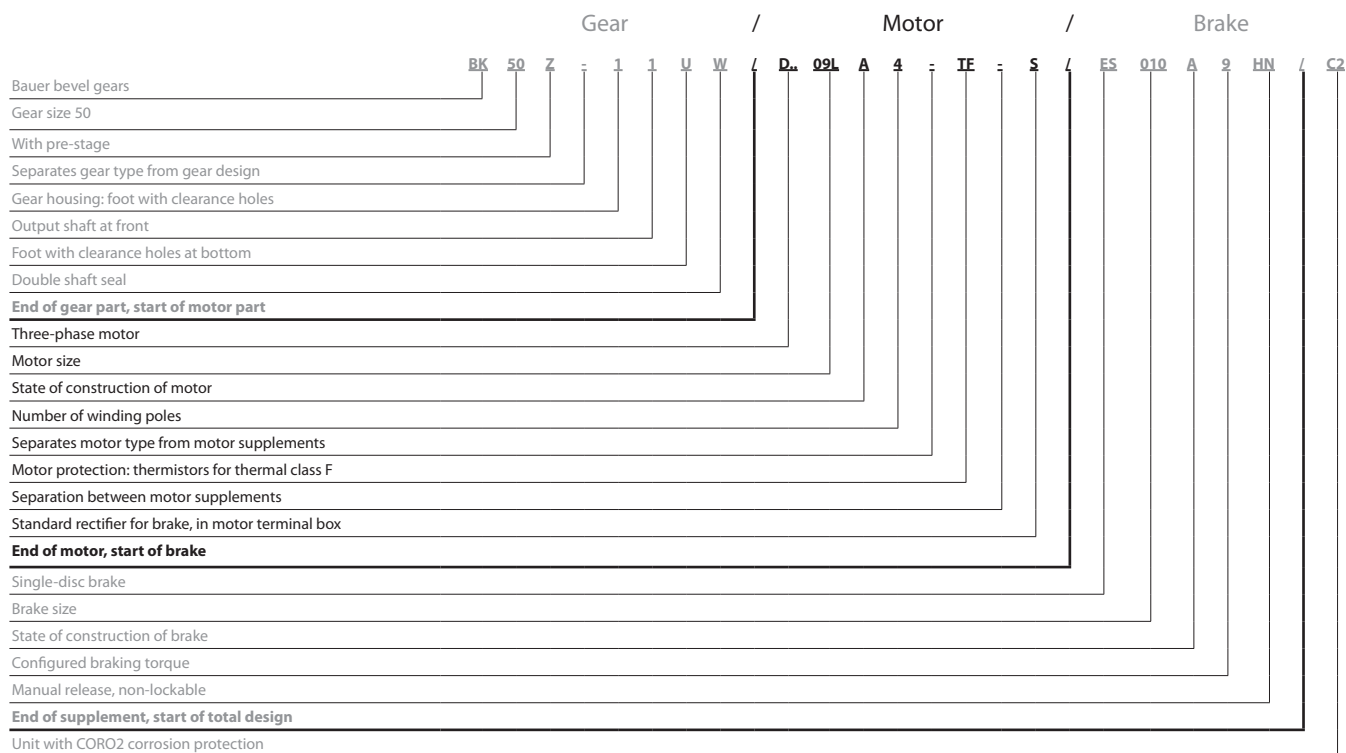

Three-phase motor

D	=	Three-phase motor
E	=	Single-phase motor (Steinmetz circuit)
S	=	PM-Synchronous motor
. A	=	Aseptic motor (germ-free drive)
. SE	=	Three-phase motor with enhanced efficiency compliant with IE1
. HE	=	Three-phase motor with enhanced efficiency compliant with IE2
. PE	=	Three-phase motor with enhanced efficiency compliant with IE3
. N	=	Motor without gear unit; foot-mount version
. NF	=	Motor without gear unit; flange-mount version
. R	=	Roller table motor
. XE	=	Explosion-proof motor with increased safety
. XD	=	Explosion-proof motors
. W	=	Torque motor
. L	=	Special rotor for traction and slewing gear motors
. C	=	With main and auxiliary windings; only with single-phase motors (EC...)
. V	=	Multiple voltage ranges (wide voltage range)
. U	=	Unventilated (no forced ventilation)

Motor protection

TB	=	Thermistor 140°
TF	=	Thermistor 160°
TH	=	Thermistor 180°
TEB	=	Thermistor warning/shutdown 120°/140°
TBF	=	Thermistor warning/shutdown 140°/160°
TFH	=	Thermistor warning/shutdown 160°/180°
TOB	=	Thermostatic switch, NC 140°
TOF	=	Thermostatic switch, NC 160°
TOH	=	Thermostatic switch, NC 180°
TSB	=	Thermostatic switch, NO 125°
TSF	=	Thermostatic switch, NO 160°
TSH	=	Thermostatic switch, NO 180°
TX	=	Other

Brake rectifier

in motor terminal box

S	=	Standard rectifier	SG
E	=	Special rectifier	ESG
M	=	Special rectifier	MSG

Plug connector	ST	= Harting (other)
Heavy-duty fan	SL	
Protective cover	D	
CleanDrive™	CD	= Aseptic drive with cable

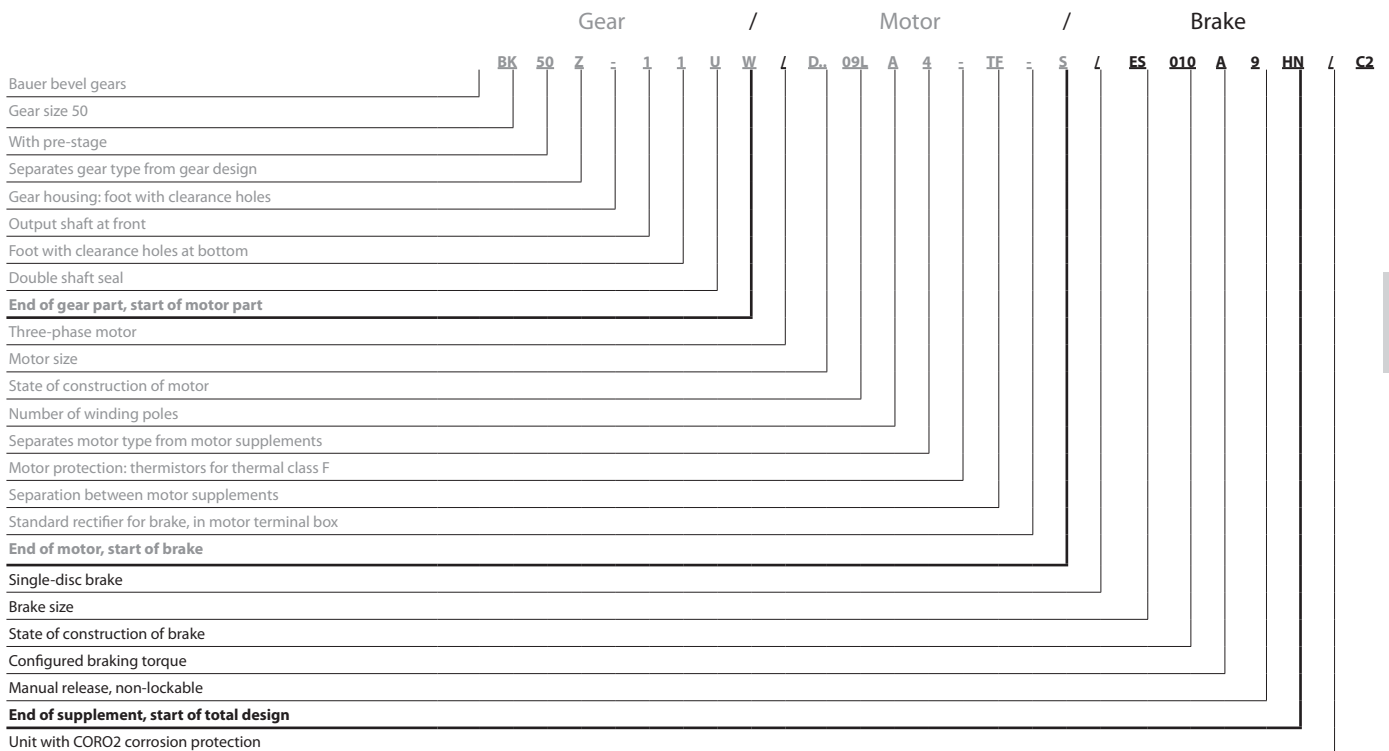

Brake

- E = Single-disc brake
- ES = Single-disc holding brake
- EH = Single-disc holding brake in heavy duty
- ZS = Two-disc holding brake
- ESX = Single-disc service brake
- EHX = Single-disc service brake in heavy duty version
- ZSX = Two-disc service brake
- ... 010 = Brake size
- A = Construction state
- 9 = Code for configured braking torque
- HN = Manual release (not lockable)
- HA = Manual release (lockable)

Reverse rotation block

- RR = Blocking direction clockwise
- RL = Blocking direction anticlockwise

Digital and analogue encoder

G

Second shaft end

- ZW = With key
- ZV = With square shaft

Forced ventilation

FV

Overall design

- AV = USA/Canada version with shaft dimensions in inches
- AM = USA/Canada version with metric shaft dimensions
- UL = US version
- CS = Canadian version
- C1 = Coro1 corrosion protection
- C2 = Coro2 corrosion protection
- C3 = Coro3 corrosion protection
- SP = Non-catalogue version

