

Page

Motor-mounted components

473-498

- Brake**
 - Encoder System**
 - Incremental Encoder**
 - Absolute Encoder**
 - Modular Motor System**
-

Motor Mounted Components

Brake

Functional description

The compression springs act on the anchor disc, which is free to move in the axial direction and presses the brake disc, which is keyed to the rotor shaft, against the friction plate or the motor bearing plate. This produces the braking torque.

When a DC voltage is applied to the coil in the electromagnet housing, it generates a magnetic force that opposes the spring force and causes the anchor disc to be pulled toward the electromagnet enclosure.

This releases the brake disc and disengages the brake.

Brakes are classified into two types according to how they are used: holding brakes and service brakes.

Holding brake ES.. / ZS..

brake that in normal operation does not convert kinetic energy into frictional energy but is only used to hold a mechanism in a particular position, but which can also be used for motion braking in an emergency.

Service brake ESX.. / ZSX..

A brake that converts kinetic energy into frictional energy in normal operation, which means that it brakes mechanical motion.

When a service brake is used as a holding brake, the braking torque tolerance of up to -30 % (in new condition) must be taken into account.

Product description of type ES(X) spring-actuated brakes

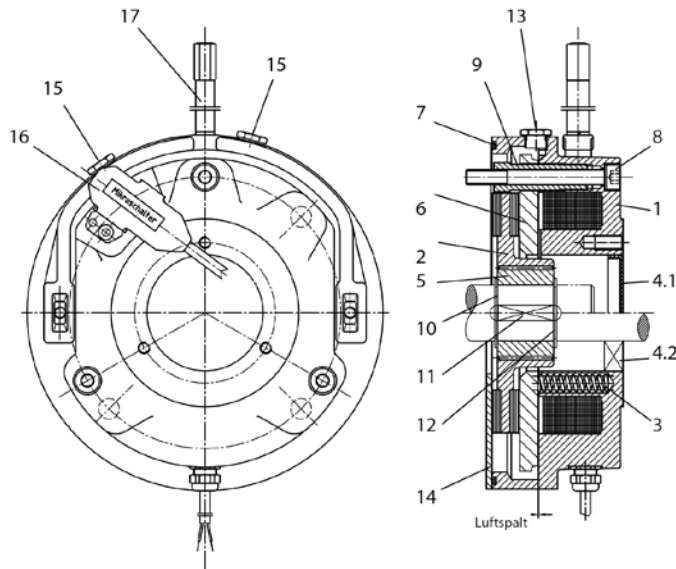

Figure 1: Construction of ES(X) brake

Brake mounting

ES and ESX: Brake mounting is under the fan cover
 EH and EHx: Brake mounting is on the fan cover

Options

- Manual release, non-locking or locking
- Microswitch for monitoring operation or wear

Construction

- | | |
|-----|--|
| 1 | Electromagnet housing |
| 2 | Brake disc |
| 3 | Compression spring |
| 4.1 | Cover plate with closed brake |
| 4.2 | Shaft seal with through shaft |
| 5 | Drive bush |
| 6 | Anchor disc |
| 7 | O-ring |
| 8 | Fitting screw with copper washer |
| 9 | Hollow screw |
| 10 | Retaining ring |
| 11 | Key |
| 12 | Retaining ring |
| 13 | Screw plug for checking air gap |
| 14 | Friction plate (only with motor size Dxx08 or Dxx09) |
| 15 | Screw plug for checking microswitch setting |
| 16 | Microswitch (optional) |
| 17 | Manual release (optional) |

Product description of type ZS(X) spring-actuated brakes

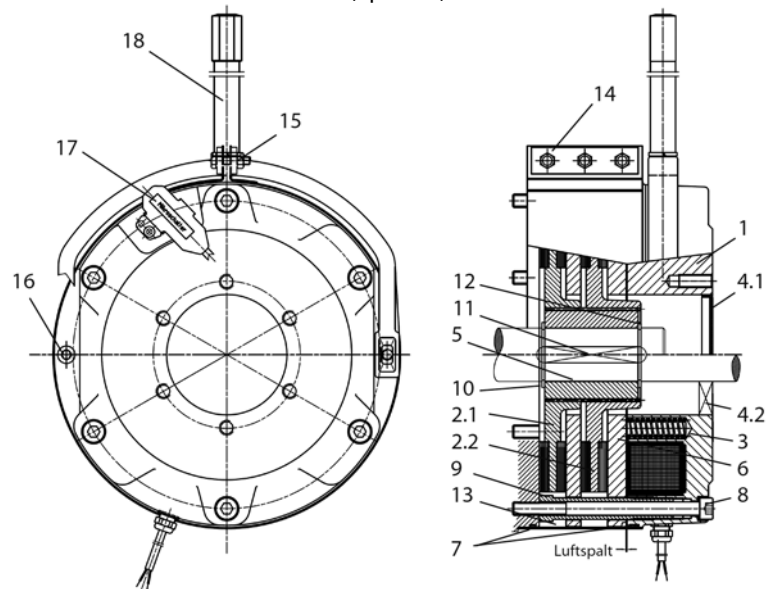

Figure 2: ZS(X) brake construction

Motor Mounted Components

Brake

Options

- Manual release, non-locking or locking
- Microswitch for monitoring operation or wear

Construction

1	Electromagnet housing
2	Brake disc 2.1 and 2.2
3	Compression spring
4.1	Cover plate
4.2	Shaft seal with through shaft
5	Drive bush
6	Anchor disc
7	O-ring
8	Fitting screw with copper washer
9	Hollow screw
10	Retaining ring
11	Key
12	Retaining ring
13	Cover
14	Fitting screws
15	Bracket
16	Assembly screw/assembly aid
17	Microswitch (optional)
18	Manual release (optional)

Brake selection and sizing

If the service brake is undersized, it will have increased wear and a shorter lifetime. If it is oversized, the resulting mechanical forces may overload the drive.

If specific application data is not available, in the case of horizontally driven equipment we recommend selecting a braking torque with a safety factor (K) of 1 to 1.5 times the rated torque of the motor.

For braking to standstill, the selected braking torque should be at least 80% of the rated torque of the drive.

Rated torque:

$$M_{\text{Berf}} = \frac{P \times 9550}{n_2} \times K$$

M_{Berf}	Braking torque	[Nm]
P	Motor power	[kW]
n	Rated speed at rotor shaft	[rpm]

For lifting operation, a braking torque equal to twice the rated motor torque should always be chosen for safety reasons.

If the moment of inertia, speed and allowable deceleration time of the machine are known, the braking torque can be calculated as described below.

External moments of inertia

If the masses to be decelerated by the brake do not run at the same speed as the rotor shaft, the moment of inertia (J_{ext}) must be reduced to the value at the rotor shaft

$$J_{\text{ext}'} = \frac{J_{\text{ext}}}{i^2}$$

or the external moment of inertia reduced by the gear ratio of the gear unit to the value at the rotor shaft.

$$J_{\text{ext}'} = \frac{J_{\text{ext}}}{i^2}$$

J_{ext}	Total external moment of inertia [kgm ²]
$J_{\text{ext}'}$	Total external moment of inertia referenced to the rotor shaft [kgm ²]
$J_{\text{ext}1,2,\dots}$	Individual external moments of inertia [kgm ²]
i	Gear reduction ratio
n	Rotor shaft speed
$n_{1,2,\dots}$	Speeds of the individual moments of inertia [rpm]

Load torque under static load

$$M_L = F \times r$$

M_L	Load torque [Nm]
F	Force [N]
r	radius [m]

Braking torque with dynamic load

A purely dynamic load is present when flywheels, rolls, etc. must be decelerated and the static load torque is negligible.

$$M_a = \frac{J_{\text{ges}} \times n_a}{9,55 \times (t_a - t_A)} = \frac{(J_{\text{ext}'} + J_{\text{rot}} + J_{\text{Br}}) \times n_a}{9,55 \times (t_a - t_A)}$$

J_{br}	Moment of inertia of the brake [kgm ²]
J_{rot}	Moment of inertia of the rotor shaft and rotor [kgm ²]
M_a	Deceleration torque [Nm]
n_a	Initial speed at start of deceleration [rpm]
t_a	Total deceleration time (from switch-off until drive is stationary) [s]
t_A	The response time of the brake for braking corresponds to t_{AC} or t_{DC} in the specification tables [s]

Dynamic and static loads

In most application situations, both static and dynamic loads are present.

$$M_{\text{Berf}} = (M_a \pm M_L) \times K \quad \text{where} \quad M_{\text{Berf}} \leq M_{\text{Br}} \quad \text{must hold true.}$$

M_L braking (positive) or driving (negative) load torque [Nm]

Heat generated by each brake cycle

Friction converts the kinetic energy of the moving masses into heat. This amounts to

$$W = \frac{J_{\text{ges}} \times n^2}{182,5} = \frac{(J_{\text{ext}'} + J_{\text{rot}} + J_{\text{Br}}) \times n_a^2}{182,5} \quad \text{where} \quad W \leq W_{\text{max}} \quad \text{must hold true.}$$

W	Braking energy for each brake cycle [J]
M_{max}	Maximum permissible frictional energy per brake cycle (see brake tables)

Thermally allowable braking energy of service brakes

With a uniform sequence of brake cycles, which means a certain average number of brake cycles per hour, the temperature rises until an equilibrium between heat input and heat dissipation is reached. The temperature rise must be sized to avoid overheating the coil and the friction layer, taking the ambient temperature into account.

Braking to standstill:

$$W_z = W \times Z \leq W_{th}$$

W_{th}	Maximum allowable braking energy per hour
W_z	Braking energy with Z brake cycles
Z	Number of brake cycles per hour

Lifting operation

In lowering operation, the drive motor acts as a generator and its braking effect results in a steady downward motion (constant speed). If we ignore transmission losses, under full load the drive must brake the load with the rated motor torque. If a mechanical brake with a braking torque equal to the braking torque of the motor is applied after the drive is switched off, the downward motion will continue at the same speed. This means that additional braking torque is necessary to stop the motion of the load. For example, if the brake is dimensioned for 200% braking torque, approximately 100 % is used for "static" deceleration and the rest is used for "dynamic" deceleration. If part of the braking torque is required for braking the load during lowering (downward motion), the brake engagement time is greater, and the thermal load is therefore greater.

In this case

$$W_H = \frac{M_{Br}}{M_{Br} - M_L} \times W_z$$

W_H	Friction energy per hour in lifting operation
M_{Br}	Braking torque of the brake

Brake lifetime

The energy absorbed during braking causes the brake disc to wear, which increases the air gap. If the air gap increases beyond a certain maximum gap size, the magnetic field is so weak that the pulling force of the electromagnet is no longer sufficient to release the brake. A proper air gap must be restored by adjusting the air gap or by replacing the brake disc, depending on the type of brake construction.

The maximum number of brake cycles until service is necessary can be calculated as follows:

$$Z_L = \frac{W_L}{W}$$

Z_L	Number of brake cycles until the air gap limit is reached
W_L	Maximum allowable braking energy until maintenance; i.e. replacing the brake disc or adjusting the air gap. Adjustment of the air gap is possible only with type ZX5xx brakes.

Deceleration time

The pure braking time from the start of mechanical braking to standstill depends on the braking deceleration.

Especially with lifting operation, but also in other types of operation, it is necessary to check whether the load torque reinforces the braking effect or counters the braking effect.

The deceleration time is therefore calculated as follows:

$$t_a = \frac{J_{ges} \times n_a}{9,55 \times (M_{Br} \pm M_L)}$$

Electrical connection

General

There are two basic options for providing the supply voltage for the DC electromagnet:

1. Externally from an existing DC control voltage mains or a rectifier in the cabinet.
2. From a rectifier built into the motor or brake terminal box. In this case, the rectifier can be powered either directly from the motor terminal board or from the mains.

Note that in the following cases the rectifier is not allowed to be connected to the terminal board of the motor:

- Pole-changing motors and motors with wide operating voltage range
- Operation from a frequency converter
- Other configurations in which the motor voltage is not constant, such as operation with soft-start devices, start-up transformers, etc.

Release

When the rated voltage is applied to the electromagnet coil, the current through the coils increases exponentially and with it the generated magnetic field. The current must rise to a certain value (I_{release}) before it overcomes the spring force and starts to release the brake.

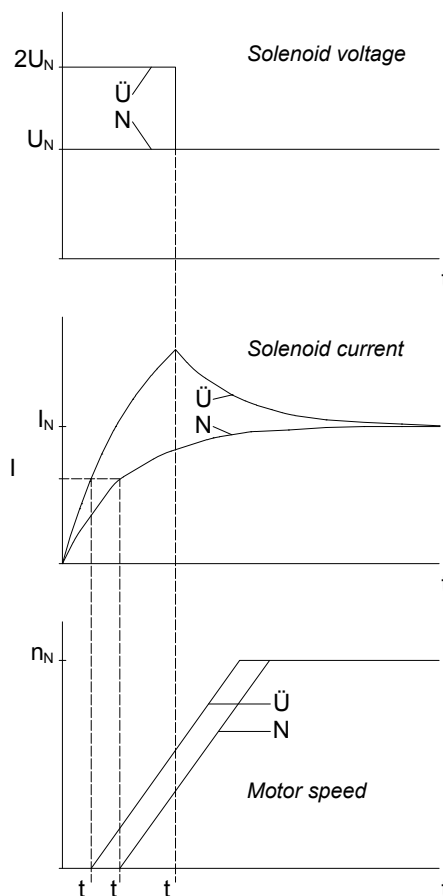

Figure 3: Idealized curves of coil voltage, coil current and motor speed with normal excitation (N) and overexcitation (Ü).
 t_0 : overexcitation time; t_{AN} , $t_{AÜ}$: Response time with normal excitation and overexcitation.

Two different situations can arise during the response time t_A , assuming that the voltage is applied to the motor and the brake simultaneously:

- The motor is locked if $M_A < M_L + M_{Br}$
The motor draws its locked-rotor current, which increases the thermal load on the motor.
This situation is illustrated in Figure 3.
- The brake slips if $M_A > M_L + M_{Br}$
In this case, the brake is also thermally stressed during start-up and wears faster.

M_A : locked rotor torque of the motor; M_L : load torque; M_{Br} : braking torque

As can be seen, there is an additional load on the motor and brake in both cases. The effect of the response time increases with increasing brake size. Consequently, it is advisable to reduce the response time, especially with medium-sized and large brakes and with a high cycle rate. This can be achieved relatively easily by means of electrical overexcitation. With this approach, the coil is briefly operated at twice its rated voltage after switch-on.

This causes the current to rise faster than with normal excitation, and it reduces the response time by approximately 50%. This overexcitation function is built into the type MSG special rectifier.

The release current increases with increasing air gap, and with it the response time. When the release current exceeds the rated coil current, the brake will not be released with normal excitation and the brake has reached its wear limit.

Braking

The brake does not start generating braking torque immediately after the coil voltage is switched off. First the magnetic energy must decline to the point that the spring force can overcome the magnetic force. This occurs at the holding current I_{hold} , which is lower than the release current.

The response time depends on how the voltage is switched off.

Switching off the AC supply voltage to a type SG standard rectifier

- a) Rectifier powered from the motor terminal board (Figure 4, curve 1)
Response time t_{A1} : very long

Cause: Due to the residual magnetism of the motor, after the motor voltage is switched off a slowly decaying voltage is induced, and it continues to supply power to the rectifier and thereby to the brake. In addition, the magnetic energy of the brake coil is dissipated relatively slowly in the freewheel circuit of the rectifier.

- b) Rectifier powered separately (Figure 4, curve 2)
Response time t_{A2} : long

Cause: After the rectifier voltage is switched off, the magnetic energy of the brake coil is dissipated relatively slowly in the freewheel circuit of the rectifier.

If the supply voltage is interrupted on the AC side, no significant switch-off voltage occurs on the electromagnet coil.

Interrupting the DC circuit of the electromagnet coil (Figure 4, curve 3)

- a) By a mechanical switch
 - with separate power supply from a DC control voltage mains or
 - at the DC switch contacts (A2 and A3) of the type SG standard rectifier
 Response time t_{A3} : very short

Cause: The magnetic energy of the brake coil is dissipated very quickly by arcing across the switch contacts.

b) Electronic

Using a type ESG or MSG special rectifier
 Response time t_{A3} : short

Cause: The magnetic energy of the brake coil is dissipated quickly by a varistor integrated in the rectifier.

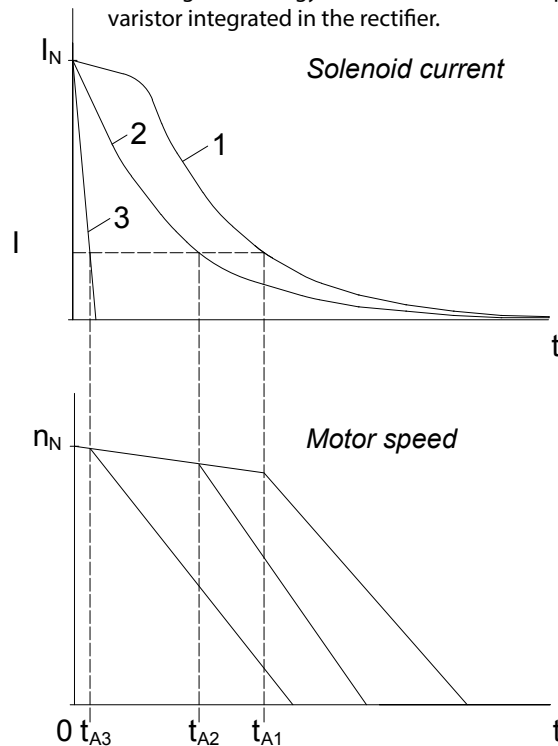

Figure 4: Idealized coil current and motor speed curves after switching off power on the AC side (1 and 2) or DC side (3)

If the circuit is interrupted on the DC side, a high voltage u_q is induced by the electromagnet coil. The magnitude of this voltage depends on the inductance L of the coil and the switch-off speed di/dt according to the formula

$$u_q = L \cdot \frac{di}{dt}$$

Due to the winding design, the inductance L increases with increasing rated coil voltage. Consequently, the voltage spikes induced at switch-off can reach hazardous levels with relatively high coil voltages. For this reason, a varistor is included in the circuit for all brakes with voltages greater than 24 V.

This varistor is solely intended to protect the electromagnet coil; it is not intended to protect adjacent electronic components or devices against electromagnetic interference. On request, brakes with rated voltages of 24 V or less can also be fitted with a varistor.

If the circuit is interrupted on the DC side by a mechanical switch, the resulting arcing over the switch contacts causes strong erosion of the contacts. For this reason, only special DC contactors or adapted AC contactors with contacts rated for use class AC3 as specified in EN 60947-4-1 may be used.

Motor Mounted Components

Brake

Specifications of holding brakes with emergency stop capability

The maximum allowable friction energy values stated here do not apply to brake motors for use in areas with potentially explosive atmospheres. Refer to separate data in appropriate documents for explosion-proof drives.

Type	M _{Br}	W _{max}	W _{th}	W _L	t _a	t _{AC}	t _{DC}	P _{el}	J
	[Nm]	[10 ³ J]	[10 ³ J]	[10 ⁶ J]	[ms]	[ms]	[ms]	[W]	[10 ⁻³ kgm ²]
E003B9	3	1.5	-	-	35	150	15	20	0.01
E003B7	2.2	1.8	-	-	28	210	20		
E003B4	1.5	2.1	-	-	21	275	30		
E004B9	5	2.5	-	-	37	125	15	30	0.017
E004B8	4	3	-	-	30	160	18		
E004B6	2.8	3.6	-	-	23	230	26		
E004B4	2	4.1	-	-	18	290	37		
E004B2	1.4	4.8	-	-	15	340	47		
ES010AX	15*	3	-	-	110	-	30	35	0.045
ES010A9	10	3	-	-	60	100	15		
ES010A8	8	3	-	-	55	150	20		
ES010A5	5	3	-	-	45	220	20		
ES010A4	4	3	-	-	30	250	20		
ES010A2	2.5	3	-	-	25	350	25		
ES027AX	32*	2.5	-	-	80	-	30		
ES/EH027A9	27	2.5	-	-	120	100	15	50	0.172
ES/EH027A7	20	2.5	-	-	100	130	20		
ES/EH027A6	16	2.5	-	-	80	170	25		
ES/EH040A9	40	3.5	-	-	100	100	20	65	0.45
ES/EH040A8	34	3.5	-	-	80	200	25		
ES/EH040A7	27	3.5	-	-	70	250	30		
ES070AX	90*	3.5	-	-	120	-	40		
ES070A9	70	3.5	-	-	120	150	18	85	0.86
ES070A8	63	3.5	-	-	120	200	20		
ES070A7	50	3.5	-	-	90	220	25		
ES/EH125A9	125	4.5	-	-	170	220	25		
ES/EH125A8	105	4.5	-	-	150	320	28	105	1.22
ES/EH125A7	85	4.5	-	-	135	350	30		
ES/EH125A6	70	4.5	-	-	120	440	35		
ES125A5	57	4.5	-	-	100	600	40		
ES125A3	42	4.5	-	-	90	700	45		
ES/EH200A9	200	8	-	-	400	150	22	105	2.85
ES/EH200A8	150	8	-	-	280	250	35		
ES/EH200A7	140	8	-	-	200	320	35		
ES250AX	350*	9	-	-	180	-	70	135	6.65
ES250A9	250	9	-	-	300	500	45		
ES250A8	200	9	-	-	200	960	60		
ES250A6	150	9	-	-	160	1100	60		
ES250A5	125	9	-	-	150	1500	90		
ES250A4	105	9	-	-	130	1800	110		
ZS300A9	300	8	-	-	280	220	35		
ZS300A8	250	8	-	-	210	380	45		
EH400A9	400	10	-	-	300	600	60	180	19.5
EH400A7	300	10	-	-	200	850	75		
EH400A5	200	10	-	-	150	1400	85		
ZS500A9	500	9	-	-	320	320	50	100	13.3
ZS500A8	400	9	-	-	260	600	60		
ZS800A9	800	20	-	-	400	550	65	140	38.5
ZS800A7	600	20	-	-	320	920	80		
ZS800A5	400	20	-	-	250	1450	100		

* Requires overexcitation; permissible only with MSG rectifier

Braking torque tolerance: -10 / +30 %

W_{th} and W_L are not specified because little or no braking energy is dissipated by holding brakes when they are used as intended.

For versions with braking torque marked with *, which may only be used with an MSG rectifier, the values of t_a and t_{DC} apply to operation with an MSG rectifier; i.e. t_a for overexcitation or t_{DC} for electronic circuit interruption on the DC side.

Due to the effects of operating temperature and manufacturing tolerances, actual response times may differ from the guideline values listed here.

Motor Mounted Components

Brake

Specifications of service brakes

The maximum braking energy values stated here do not apply to brake motors for use in areas with potentially explosive atmospheres. Refer to separate data in appropriate documents for explosion-proof drives.

Type	M _{Br} [Nm]	W _{max} [10 ³ J]	W _{th} [10 ³ J]	W _L [10 ⁶ J]		t _A [ms]	t _{AC} [ms]	t _{DC} [ms]	P _{el} [W]	J [10 ⁻³ kgm ²]
				without HL	with HL					
E003B9	3	1.5	36	55	55	35	150	15	20	0.01
E003B7	2.2	1.8	36	90	90	28	210	20		
E003B4	1.5	2.1	36	140	140	21	275	30		
E004B9	5	2.5	60	50	50	37	125	15	30	0.017
E004B8	4	3	60	100	100	30	160	18		
E004B6	2.8	3.6	60	180	180	23	230	26		
E004B4	2	4.1	60	235	235	18	290	37		
E004B2	1.4	4.8	60	310	310	15	340	47		
ESX010AX	15*	3	250	120	120	110	-	30	35	0.045
ESX010A9	10	3	250	120	120	60	100	15		
ESX010A8	8	3	250	150	150	55	150	20		
ESX010A5	5	3	250	240	240	45	220	20		
ESX010A4	4	3	250	300	240	30	250	20		
ESX010A2	2.5	3	250	390	240	25	350	25		
ESX027AX	27*	10	350	150	150	80	-	30		
ESX/EHX027A9	22	10	350	150	150	120	100	15	50	0.172
ESX/EHX027A7	16	10	350	300	300	100	130	20		
ESX/EHX027A6	13	10	350	350	350	80	170	25		
ESX/EHX040A9	32	20	450	420	420	100	100	20	65	0.45
ESX/EHX040A8	27	20	450	560	490	80	200	25		
ESX/EHX040A7	22	20	450	700	490	70	250	30		
ESX070AX	72*	28	550	700	700	120	-	40	85	0.86
ESX070A9	58	28	550	500	500	120	150	18		
ESX070A8	50	28	550	800	700	120	200	20		
ESX070A7	40	28	550	1200	700	90	220	25		
ESX/EHX125AX	100*	40	700	1900	1900	100	-	70	105	1.22
ESX/EHX125A9	85	40	700	1700	1700	150	320	28		
ESX/EHX125A8	70	40	700	1900	1700	135	350	30		
ESX/EHX125A7	58	40	700	2700	1700	120	440	35		
ESX125A5	45	40	700	3300	1700	100	600	40		
ESX125A3	34	40	700	3300	1700	90	700	45		
ESX/EHX200AX	160*	60	850	2000	2000	105	-	70		
ESX/EHX200A9	120	60	850	1700	1700	280	250	35	105	2.85
ESX/EHX200A8	110	60	850	2600	2600	200	320	35		
ESX250AX	280*	84	1000	2300	2300	180	-	70		
ESX250A9	200	84	1000	2800	2800	300	500	45	135	6.65
ESX250A8	160	84	1000	6800	5700	200	960	60		
ESX250A6	120	84	1000	8500	5700	160	1100	60		
ESX250A5	100	84	1000	11000	5700	150	1500	90		
ESX250A4	85	84	1000	11000	5700	130	1800	110		
ZSX300A9	250	60	850	1300	1300	280	220	35	75	5.7
ZSX300A8	200	60	850	2000	2000	210	380	45		
EHX400A9	320	120	1100	3000	3000	300	600	60	180	19.5
EHX400A7	240	120	1100	4800	4800	200	850	75		
EHX400A5	160	120	1100	6000	4800	150	1400	85		
ZSX500A9	400	84	1000	2800	2800	320	320	50	100	13.3
ZSX500A8	320	84	1000	4000	4000	260	600	60		
ZSX800A9	640	120	1150	1550	1550	400	550	65	140	38.5
ZSX800A7	480	120	1150	1550	1550	320	920	80		
ZSX800A5	320	120	1150	1550	1550	250	1450	100		

* Requires overexcitation; permissible only with MSG rectifier

Braking torque tolerance:

E003 / E004: -10 / +30 %

ESXxx / ZSXxx: -20 / +30 % after run-in; up to -30 % in new condition.

For versions with braking torque marked with *, which may only be used with an MSG rectifier, the values of t_A and t_{DC} apply for operation with an MSG rectifier; i.e. t_A for overexcitation or t_{DC} for electronic circuit interruption on the DC side.

The values for W_L are guidelines; actual values may vary significantly depending on the application situation. Periodic inspection of the air gap or brake disc thickness is recommended.

Actual response times may differ from the times listed here due to the effects of operating temperature, brake disc wear and manufacturing tolerances.

Key to symbols

M_{Br}	Rated braking torque
W_{max}	Maximum allowable friction energy for an emergency stop with a holding brake
W_{max}	Maximum allowable friction energy for each brake cycle with service brakes
W_{th}	Maximum allowable braking energy per hour
W_L	Maximum allowable braking energy until maintenance; i.e. brake disc replacement or air gap adjustment. Air gap adjustment is possible only with type ZSXxx brakes.
H_L	Manual release
t_A	Response time for release with normal excitation. Overexcitation with a type MSG special rectifier reduces the response time by approximately 50 %.
t_{AC}	Response time for brakes with AC-side switch-off, i.e. by switching off the supply voltage to a separately powered standard rectifier. If the supply voltage for the rectifier is taken from the motor terminals, considerably longer response times should be expected (depending on the motor size and winding design).
t_{DC}	Response time for braking with DC-side circuit interruption by a mechanical switch. In the case of electronic circuit interruption on the DC side by a type ESG or MSG special rectifier, the response times will be approximately two to three times as long.
P_{el}	Electromagnet coil power consumption at 20° C. Depending on the rated voltage of the coil, the actual power may differ from the guideline value stated here.
J	Moment of inertia of the drive bush and brake disc(s)

Connection

The electrical connections to the brake are made in the motor terminal box using terminals or the rectifier. Standard voltages:

380–420 V 50/60 Hz (brake coil voltage 180 V DC)

220–230 V 50/60 Hz (brake coil voltage 105 V DC)

24 V DC (brake coil voltage 24 V DC)

Other voltages are available at additional cost.

DC connection via terminals (K)

The brake must be connected via separate terminals in the motor or brake terminal box directly to the DC voltage. The standard voltages are 180 V DC, 105 V DC and 24 V DC. Brakes with other operating voltages are available at additional cost.

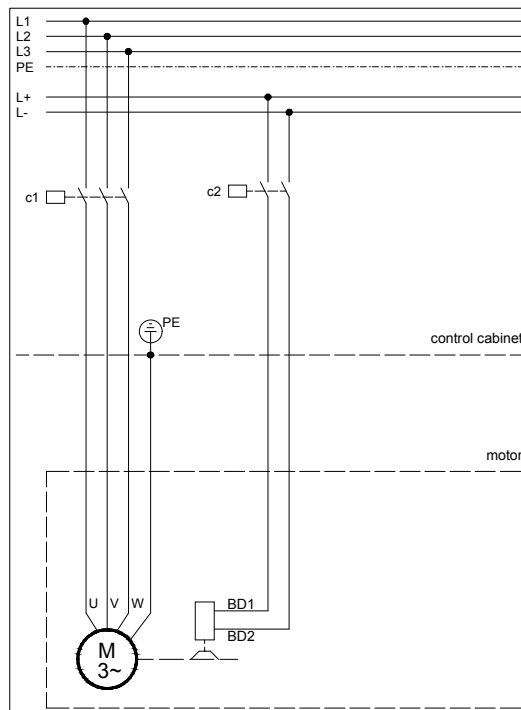

Motor Mounted Components

Brake

Standard rectifier (S)

Working principle

Half-wave rectifier with switch contacts for DC-side circuit interruption

Input voltage U_1

max. 575 VAC +5 %

Output voltage

$0.45 \times U_1$ VDC

Max. output current

2.5 A DC

Ambient temperature

-40 to +40° C

Connection

Caged Clamp terminals with clamp lever

Clampable conductor cross-section

max. 1.5 mm² without wire end sleeve

max. 1.5 mm² with wire end sleeve

Approvals

c-CSA-us

c-UL-us (only in combination with B2000 geared motors and brakes in the ES(X) or ZS(X) product series)

The brake must be connected to the AC supply via the standard rectifier in the motor terminal box or brake terminal box. The standard voltages are 380 ... 420 V 50/60 Hz or 220 ... 230 V 50/60 Hz. Other voltages up to 575 V are available at extra cost. In a configuration with standard rectifier, the brake circuit can be interrupted by an extra contact on the d.c. side in order to reduce the response time. This significantly reduces the braking time and overtravel distance.

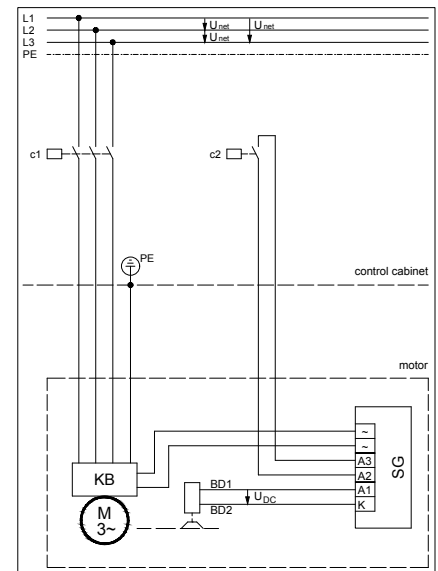
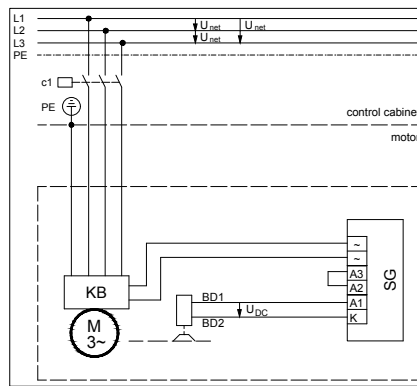

Voltage connection for the rectifier from the motor terminal block or cage clamp (see Rectifier Connection on Motor Terminal Block or Cage Clamp)

Rectifier for electronic rapid shutdown (E)

Working principle	Half-wave rectifier with electronic DC-side circuit interruption
Input voltage U_1	220–460 V AC $\pm 5\%$, 50/60 Hz
Output voltage	$0.45 \times U_1$, V DC
Max. output current	1 A DC
Ambient temperature	-20° C to +40° C
Clampable conductor cross-section	max. 1.5 mm ²

This rectifier permits electronic DC-side interruption of the brake circuit. No additional cable to the rectifier is necessary. The rectifier is supplied complete with a protective resistor which prevents a mains short-circuit via the shutdown arc of the high-speed motor contactor. Brake response times are significantly shorter than those achievable by AC-side interruption of the brake circuit. They are, however, longer than those achievable with DC-side interruption by a mechanical switch. The brake must be connected to the alternating current via the rapid shutdown rectifier in the motor terminal box or the brake terminal box. The standard voltages are 380 ... 420 V 50/60 Hz or 220 ... 230 V 50/60 Hz. Other voltages up to 460 V are available at extra cost.

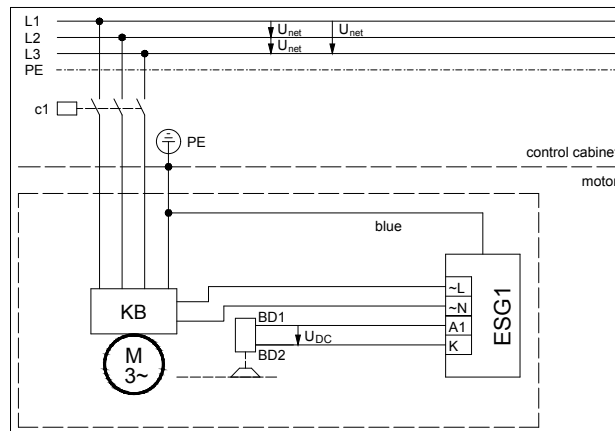

Voltage connection for the rectifier from the motor terminal block or cage clamp (see Rectifier Connection on Motor Terminal Block or Cage Clamp)

Motor Mounted Components

Brake

Standard rectifier (M)

Working principle	MSG 1.5.480I Half-wave rectifier with time-limited overexcitation and electronic DC-side circuit interruption Fast shutdown due to no motor current in one phase
Input voltage U_1	220–480 V AC +6 / -10 %, 50/60 Hz
Output voltage	0.9 x U_1 V DC during overexcitation 0.45 x U_1 V DC over overexcitation period
Overexcitation time	0.3 s
Max. output current	1.5 A DC
Ambient temperature	-20° C to +40° C
Clampable conductor cross-section	max. 1.5 mm ²

Working principle	MSG 1.5.500U Half-wave rectifier with time-limited overexcitation and electronic DC-side circuit interruption Fast shutdown due to the absence of input voltage
Input voltage U_1	220–500 V AC ±10 %, 50/60 Hz
Output voltage	0.9 x U_1 V DC during overexcitation 0.45 x U_1 V DC over overexcitation period
Overexcitation time	0.3 s
Max. output current	1.5 A DC
Ambient temperature	-20° C to +40° C
Clampable conductor cross-section	max. 1.5 mm ²

In cases where there are high motor switching frequencies, the brake can be de-energized more rapidly with this rectifier thereby significantly reducing the thermal stress on the motor. In addition, interrupting the brake's DC circuit by electronic means significantly reduces response times. Depending on the circumstances in which they are to be used, either the MSG 1.5.500 U (rapid shutdown brought about by removed supply voltage) or MSG 1.5.480 I (rapid shutdown brought about by removed motor current in a phase) is used. Power supply 220 to 480 V AC.

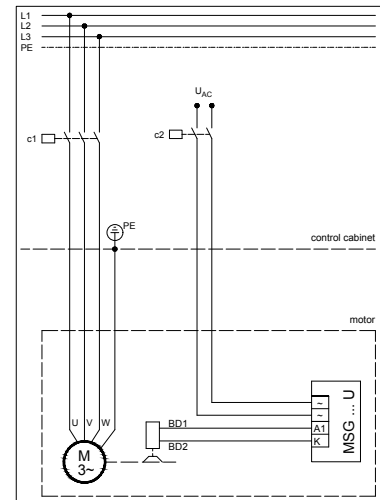
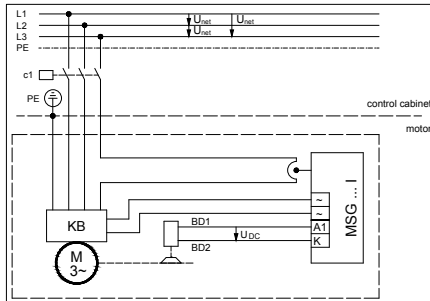

Motor Mounted Components

Brake

Rectifier Connection on Motor Terminal Block or Cage Clamp

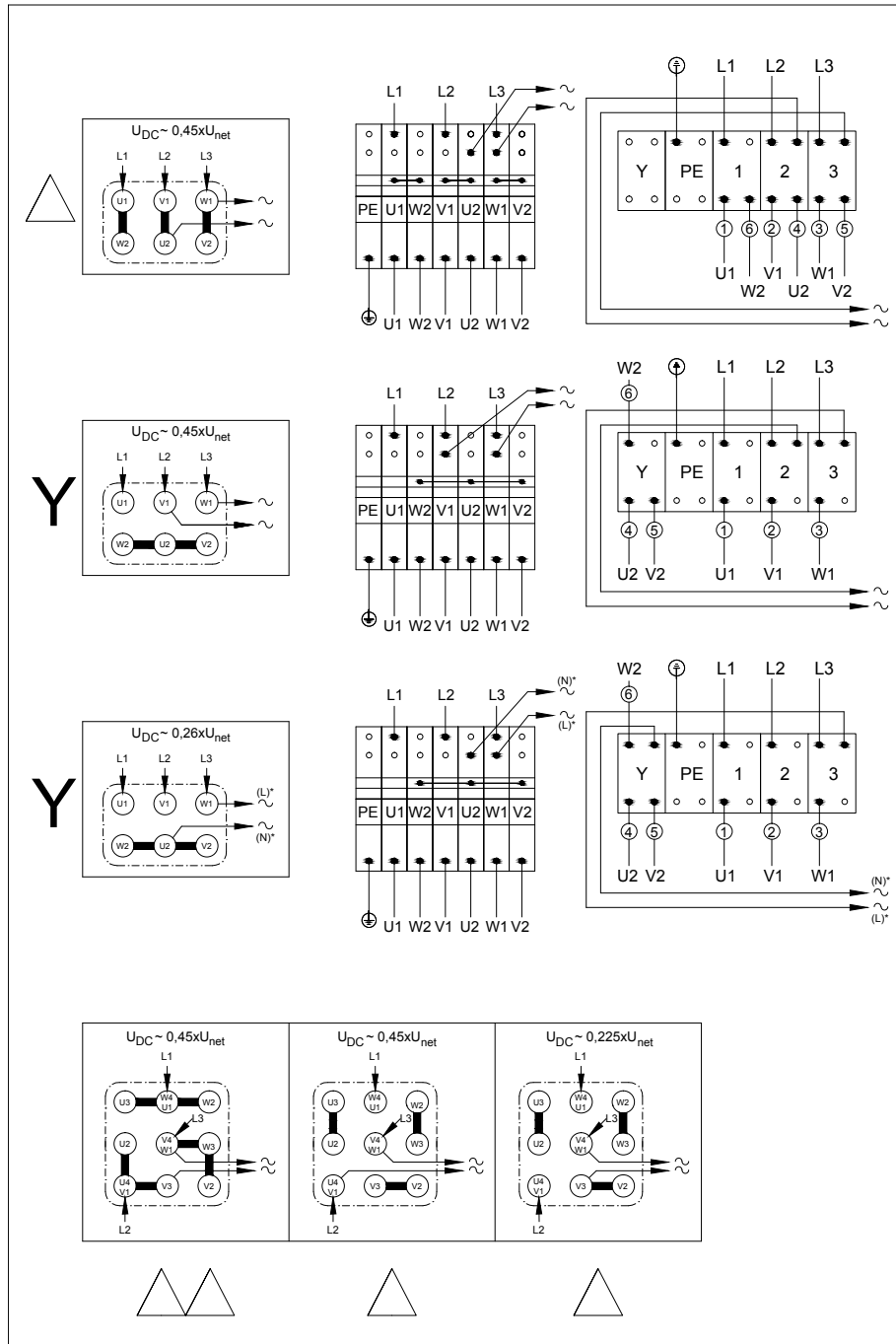

Motor Mounted Components

Brake

Brake connection, operation with frequency converter

The voltage present at the motor terminal block when operating with a frequency converter is frequency-dependent. Brakes require a constant voltage, so they need a separate electrical connection. This is the reason why the brake is not connected to the motor terminals ex-works.

Brake connection, pole-changing motors

The brakes of pole-changing motors need a separate electrical connection. As is the case with motors for operation with frequency inverters, the brake is not connected to the motor terminals ex-works.

Manual release (HA, HN)

All brakes are available with mechanical manual release on request. Non-latching manual release is the standard version (HN). A latching manual release (HA) can be supplied if required for all brake sizes.

Degree of protection

All BAUER brakes comply with degree of protection IP 65.

Special corrosion protection

If high requirements for corrosion resistance apply, the brakes are available with two levels of enhanced corrosion protection:

- CORO1 (C1):** Finished with two-component paint to protect against chemically aggressive gases and vapors.
- CORO2 (C2):** Same finish as CORO1. The screws for the terminal-box cover are non-rusting steel. The mechanical internals of the brake are made of corrosion-proofed material.

CE mark

BAUER geared motors with externally mounted spring-loaded brakes bear the CE mark.

The brakes comply with:

- the **Machinery Directive (2006/42/EG)**
Manufacturer's declaration available on request
- the **Low-Voltage Directive (2006/95/EG)**
Documented by the CE mark
- the **EMC Directive (2004/108/EG)**
Documented by the CE mark

See BAUER special print SD33.. for more information.

Explosion protection

Brakes for use in hazardous areas are subject to special regulations. Please consult our support specialists in these special cases.

Back stop (RR, RL)

Motors of size D..09 (1,1kW) up to D..18 (30kW) are available with backstop. The locking rotational direction clockwise (RR) or anticlockwise (RL) is to be given in the order. The reference is the connection side of the gearbox. Should the connection side not be clearly defined, gearbox side "V" (front) will be assumed (see chapter 17 Dimensions drawing "Motor with back stop").

Note that the back-stop functionality on a motor operating with a frequency converter is guaranteed only at rotor speeds above 670/min.

It is advisable to consult BAUER for applications in corrosive atmospheres, especially for motor-down installed positions.

Second motor extension (ZW, ZV)

The motors are also available on request with a second motor shaft extension in design ZW (shaft with key) or ZV (shaft with square end).

Half the central motor's rated power is available at each of the two shafts. Permissible radial loads available on request. Guards are not included in the scope of supply (for dimensional drawing see chapter 17).

Motors with brakes are available on request with a second shaft stub extended through the brake.

Protective fan cowl (D)

A protective hood over the fan cowl is recommended for outdoor installations where the motor is pointing upward and subject to severe or prolonged exposure to water (dimensional drawing, see chapter 17).

This protective hood is mandatory for upright explosion-proof motors.

A special fan cowl for the textiles industry is available on request at extra cost. This design prevents airborne fibers and fluff clogging the fan cowl.

Motor-independent fan (FV)

For special applications, standard motors and brake motors of size D08 and larger are available with externally mounted motor-independent fans. The standard line voltage of the motor-independent fan matches the voltage of the geared motor (dimensional drawing for motor-independent fan, see chapter 17).

The independent fans are supplied as standard with Bayonet-fitting for standard motor sizes D..16 and D..18 and brake motor sizes D..11 to D..18. Standard enclosure IP66.

Technical Data:

Multivolt Conception Running capacitor for single phase duty enclosed as standard.

Mode	Frame size	Blower diameter	Range of voltage		max. permissible current	max. power input
			50 Hz	60 Hz		
		(mm)			(A)	W
1 ~ Δ (Δ)	63	118	230-277	230-277	0.12	32
	71	132	230-277	230-277	0.12	33
	80	150	230-277	230-277	0.14	37
	90	169	230-277	230-277	0.29	65
	100	187	230-277	230-277	0.30	75
	112	210	230-277	230-277	0.37	94
	132	250	230-277	230-277	0.60	149
	160-200	300	230-277	---	0.96	236
3 ~ Y	63	118	380-500	380-575	0.06	28
	71	132	380-500	380-575	0.06	29
	80	156	380-500	380-575	0.06	34
	90	169	380-500	380-575	0.19	75
	100	187	380-500	380-575	0.17	94
	112	210	380-500	380-575	0.17	99
	132	250	380-500	380-575	0.25	148
	160-200	300	380-500	380-575	0.54	360
3 ~ Δ	63	118	220-290	220-332	0.10	28
	71	132	220-290	220-332	0.10	28
	80	156	220-290	220-332	0.10	34
	90	169	220-290	220-332	0.33	78
	100	187	220-290	220-332	0.31	87
	112	210	220-290	220-332	0.31	103
	132	250	220-290	220-332	0.45	146
	160-200	300	220-290	220-332	0.91	360

Heavy cast fan impeller

A heavy cast fan impeller can be used instead of the standard fan impeller with D05 to D09 motors in applications requiring soft start or a reduction in switching shock when poles are changed. The heavy cast fan impeller reduces the permissible switching frequency of the motor.

Classification, motors and cast-iron fan impeller

Type of motor	J _{sl} (Moment of inertia of the cast-iron fan impeller)
D05/D06	0,0014 kgm ²
D07	0,0014 kgm ²
D08	0,004 kgm ²
D09	0,007 kgm ²

Motor Mounted Components

Encoder System

Shaft encoder (G)

Bauer gear motors can be fitted with either an incremental encoder or an absolute encoder for special applications. Both the standard incremental encoder and the absolute encoder are optimized and suitable for use with all modern inverters.

Bauer standard encoders as from motor frame size D05 (0,18kW) are protected against mechanical damage by means of a protective cover (Additional Dimension Sheet see chapter 17).

Special features: standard incremental encoder:

- Robust mount
- Degree of protection IP66
- EMC-tested
- Protected against polarity reversal
- Supply voltage 8-30 V DC
- A-, B- and N-lines and inverted signals or output signals as preferred
- HTL output circuit (TTL on request)
- 1024 pulses per revolution

Special features: standard absolute encoder

- Enclosure: IP66
- Steps per revolution: 8192 (13 Bit)
- Number of turns: 4096 (12 Bit) shaft turns
- Execution of electronic: SSI (Synchronous-Serial Interface)
- Output code: Gray-Code
- Supply voltage: 11-27 VDC
- Loss efficiency (no load): ≤ 3 Watt
- Output driver: RS-422 (2-wire)

Motor Mounted Components

Incremental rotary encoder

Functional description

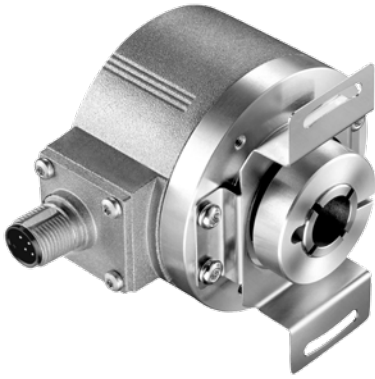

Incremental encoders are used to determine motor shaft positions. An incremental encoder detects rotary motion and converts it into an electrical output signal. An encoder disc with a specific number of periods per rotation senses angular motion. The optoelectronic scanning unit generates signals and issues pulses after the signals have been processed in trigger stages. The resolution is defined by the number of opaque and clear segments on the encoder disc. For example, an encoder with 1024 lines will generate a sequence of 1024 pulses for one full rotation.

The combination of an incremental encoder and a frequency converter allows optimised solutions to be developed, such as

- speed controllers with a wide adjustment range
- accurate speed control
- constant-speed control
- position control

Supply voltage:	8–30 V DC with HTL 5 V DC with differential TTL
Output signals:	HTL A, B and N tracks; optional TTL
Pulses per revolution:	1024 Optional 1...65536
Enclosure rating:	IP65 (optional IP67)
Temperature range:	-40° C to +100° C

Electrical specifications

Output voltage	RS 422 (TTL compatible)	RS 422 (TTL compatible)	Differential	Differential (7272)
Supply voltage	5–30 V DC	5 V ±5%	8–30 V DC	5–30 V DC
No-load current consumption With inversion:	max. 70 mA	max. 70 mA	max. 70 mA	max. 70 mA
Allowable load per channel: Pulse rate:	max. ±20 mA max. 300 kHz	max. ±20 mA max. 300 kHz	max. ±20 mA max. 160 kHz	max. ±20 mA max. 160 kHz
High signal level:	min. 2.5 V	min. 2.5 V	min. UB – 3 V	min. UB – 3 V
Low signal level:	max. 0.5 V	max. 0.5 V	max. 1 V	max. 1 V

Motor Mounted Components

Incremental rotary encoder

Plug end view with male pin insert

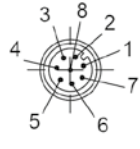
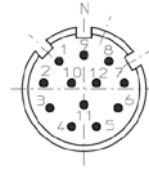
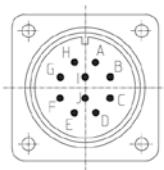
Connector type	8-pin M12 plug	12-pin M23 plug	MIL connector 10-pin
Layout			
Order code:	8.5000.XXX3.XXXX 8.5000.XXX4.XXXX	8.5000.XXX7.XXXX 8.5000.XXX8.XXXX	8.5000XXX.YXXXX
Mating 05.CMB-8181-0 connector:		8.0000.5012.0000	8.0000.5062.0000

Signal assignments

Signal:	0V GND	+U _B	0V Sens	+U _B Sens	A	A	B	B	Z	Z	Shield
M23 Multifast, 12-pin connector; pin assignments: M12 Eurofast, 8-pin connector; pin assignments:	10 1	12 2	11	2	5 3	6 4	8 5	1 6	3 7	4 8	1) 1)
Military version; 10-pin connector; pin assignments:	F	D		E	A	G	B	H	C	I	J')
Cable; lead colour:	WH	BN	GY PK	RD BU	GN	YE	GY	PK	BU	RD	Shield

¹ Shield connected to plug housing.

Insulate unused outputs before putting into service.

Functional description

Absolute encoders detect both angular and rotational motions and convert them into electrical signals. In contrast to incremental encoders, with absolute encoders the current position is directly available. If an absolute encoder is moved mechanically while it is switched off, after the power is switched on again the current position can be read out immediately and directly. Absolute encoders are available in single-turn and multi-turn versions.

Profibus DP interface

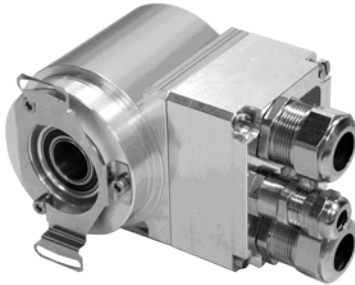

Specifications

Supply voltage	11–27 VDC
No-load current consumption	< 350 mA
Total resolution ¹	≤ 33 bits
Number of steps per revolution, standard/extended ¹	≤ 8,192 / ≤ 32,768
Number of turns, standard/extended ¹	≤ 4,096 / ≤ 256,000
Profibus DP V0	IEC 61158, IEC 61784
PNO encoder profile	Class 1/Class 2
parameters ¹	Counting direction switchover, scaling function, etc.
Output code ¹	Binary, Gray, truncated Gray
Address	3–99, set using a rotary switch
Baud rate	9.6 kbit/s to 12 Mbit/s
TR-specific functions ¹	Gear and speed outputs
Data width on bus for actual position	≤ 25 bits
Permissible mechanical speed	≤ 12,000 rpm
Shaft load	Own mass
Bearing life	≥ 3.9 x 10 ¹⁰ revolutions at
- speed	≤ 6,000 rpm
- operating temperature	≤ 60° C
Shaft diameter [mm]	10H7
Permissible angular acceleration	≤ 10 ⁴ rad/s ²
Moment of inertia	2.5 x 10 ⁻⁶ kg m ² (typical)
Start-up torque at 20 °C	2 Ncm (typical)
Weight	0.3–0.5 kg

¹ Configurable parameter

Ambient conditions

Vibration (EN 60068-2-6:1996)	≤ 100 m/s ² , sinusoidal 50–2,000 Hz
Shock (EN 60068-2-27:1995)	≤ 1000 m/s ² , half-cycle sinusoidal 11 ms
EMC	- Interference emission compliant with EN 61000-6-3:2007 - Interference immunity compliant with EN 61000-6-2:2006
Operating temperature	0° C to +60° C; optionally -20° C to +70° C
Storage temperature	-30° C to +80° C, dry
Relative humidity (EN 60068-3-4:2002)	98 %, non condensing
Enclosure rating (EN 60529:1991) ²	IP 65

²With mating connector fitted and/or cable glands fitted and tightened

Motor Mounted Components

Absolute rotary encoders

SSI interface



Specifications

Supply voltage	11–27 VDC
No-load current consumption	< 350 mA
Total resolution ¹	≤ 25 bits
Number of steps per revolution ¹	≤ 8,192
Number of rotations, standard ¹	≤ 4,096
Number of rotations, extended ¹	≤ 256,000
SSI	Synchronous Serial Interface
Clock input	Optocoupler
Data output	RS-422, 2-wire
Clock frequency	80 kHz – 1 MHz
Monostable time t_m	16 μ s ≤ t_m ≤ 25 μ s (20 μ s typical)
Output code ¹	Binary, Gray, BCD
Output format ¹	Standard, Tannenbaum, SSI + CRC, 26-bit cycle, variable number of data bits
Negative values ¹	Sign and magnitude, twos complement
SSI or parallel special bits ¹	Limit switch, overspeed, direction indication, motion indication, error indication, parity
F/R ¹	Counting direction
Preset ¹	Electronic alignment
Logic levels	"0" < +2 VDC; "1" = supply voltage
Permissible mechanical speed	≤ 12,000 rpm
Shaft load	Own mass
Bearing life	≥ 3.9 x 10 ¹⁰ revolutions at
- speed	≤ 6,000 rpm
- operating temperature	≤ 60 °C
Shaft diameter [mm]	10H7
Permissible angular acceleration	≤ 10 ⁴ rad/s ²
Moment of inertia	2.5 x 10 ⁻⁶ kg m ² (typical)
Start-up torque at 20 °C	2 Ncm (typical)
Weight	0.3–0.5 kg
Optional	
- incremental signals, RS422 levels	K1+, K1-, K2+, K2- with 1024 or 2048 pulses

¹⁾ Configurable parameter

Ambient conditions

Vibration (EN 60068-2-6:1996)	≤ 100 m/s ² , sinusoidal 50–2,000 Hz
Shock (EN 60068-2-27:1995)	≤ 1000 m/s ² , half-cycle sinusoidal 11 ms
EMC	
- Interference emission compliant with EN 61000-6-3:2007	
- Interference immunity compliant with EN 61000-6-2:2006	
Operating temperature	0° C to +60° C; optionally -20° C to +70° C
Storage temperature	-30° C to +80° C, dry
Relative humidity (EN 60068-3-4:2002)	98 %, non condensing
Enclosure rating (EN 60529:1991) ²	IP 65

²⁾ With mating connector fitted and/or cable glands fitted and tightened

In addition to the angular position within a rotation, multiturn encoders detect multiple rotations. An internal reduction gear mechanism connected to the motor shaft is used to detect the number of turns. Consequently, the value measured by a multiturn encoder consists of the current angular position and the number of turns. As with incremental encoders, the reading is calculated and output via various interface modules, depending on the interface.

On request, a large range of motor frames can be fitted with sensor bearings. The output signal from the sensor allows the direction of rotation to be determined, among other things. The number of possible pulse counts depends on the frame size. Please enquire for more information.

Motor and encoder

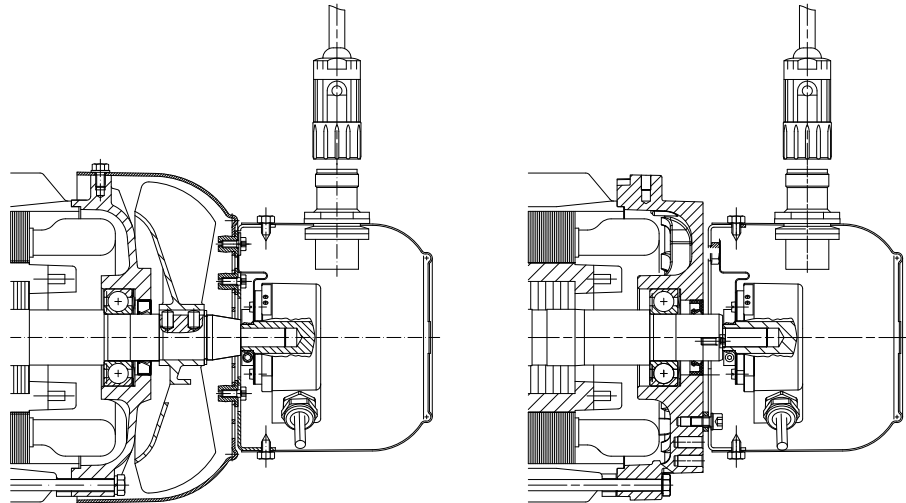

Motor, brake and encoder

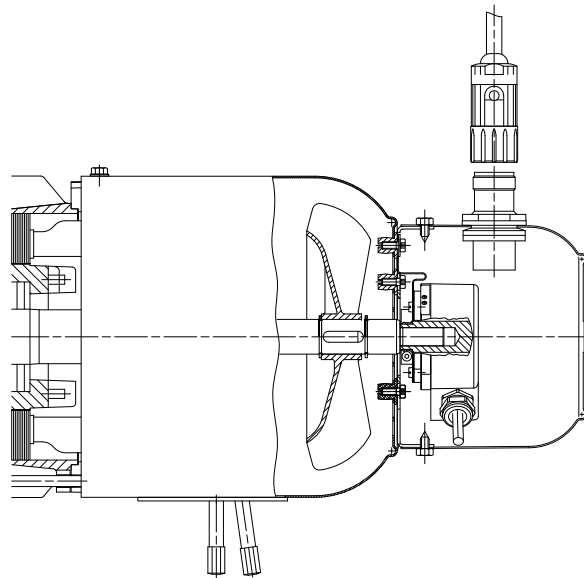

Motor and forced ventilation

