

Energy Efficient Geared Motors

AC Line Operated / European Union

BAUER		73734 Esslingen Made in Germany	
3-Mot.-No. ± 11115465-1	A/ 18905829	44/2020	
Type BK50-34V/DPE16XB4-TF			
15 kW	cosφ	0,82	S1
50 Hz	Y	380 V	30,5 A
Δ 1470	n _n	280 rpm	5,28 465 Nm
5-50-60 Hz	51-380-380 V	0,9-15-17,8 kW	
IM H3	FLU	100%	IE3 - 92,1 %
	IP 65	5,8	PGLP 220
T _a -20 ... 40 °C		180,3 kg	
CE		EN60034	

3

Type Designations

Type Designations	25
Significance of type designation	27
BG-series helical-geared motor	28
BF-series shaft-mounted geared motor	29
BK-series bevel-geared motor	30
BS-series worm-geared motor	31
Versions and options	32
BG and BF series	32
BK and BS series	32
Motor	33
Three-phase motor	33
Motor protection	33
Brake rectifier in motor terminal box	33
Plug connector	33
Heavy-duty fan	33
Protective cover	33
CleanDrive	33
Motor Mounted Components	34
Brake	34
Reverse rotation block	34
Digital and analogue encoder	34
Second shaft end	34
Forced ventilation	34
Overall design	34

Energy Efficient Geared Motors

AC Line Operated / European Union

3

Type Designations

Significance of type designation

Example: Bauer bevel-gear motor with brake and standard add-ons

Significance of type designation

The type designation of a BAUER geared motor is a code designating all the features in the drive configuration.

The build-up of the type designation is explained with the help of the following example of a bevel geared motor with brake and series options.

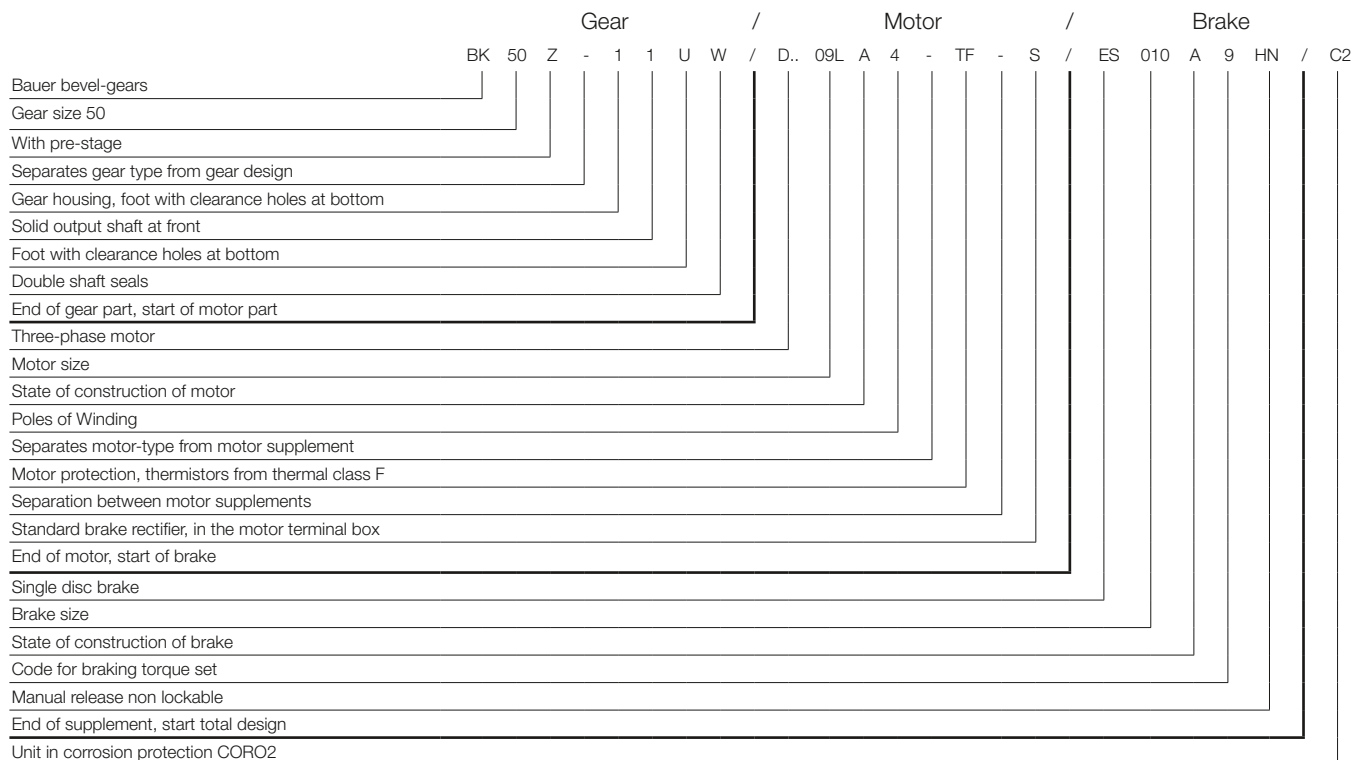

Type Designations

BG-series helical-geared motor

3

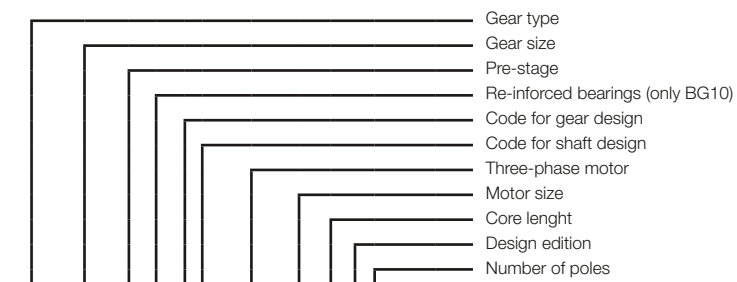

BG 10 Z X-71 / D..08 LA4

Z-... Gear with pre-stage
G-... Tandem gear

- 1. Foot with clearance holes
- 2. Small A-flange with clearance holes
- 3. Standard A-flange with clearance holes
- 4. Large A-flange with clearance holes
- 6. L Foot with tapped holes, left
- 6. R Foot with tapped holes, right
- 6. LR Foot with tapped holes, left and right
- 7. C-flange with threaded holes
- 8. Completely machined
- 9. L Foot plate, left
- 9. R Foot plate, right
- 9. LR Footplate, left and right

- . 1 Solid shaft on gear side V
- . 7 Solid shaft on gear side V for flange as from BG10
- .. W Double shaft seals

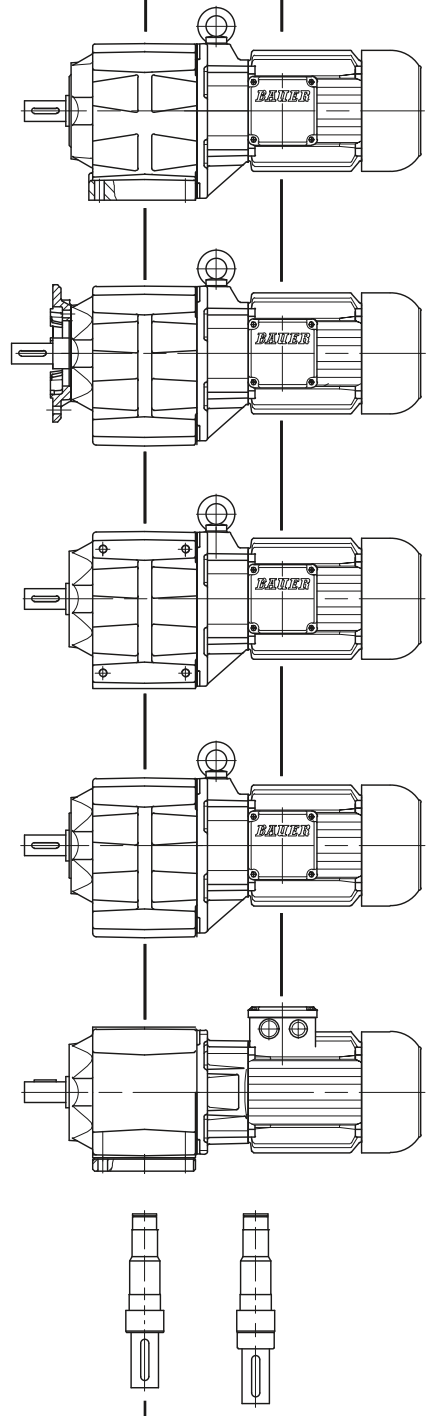
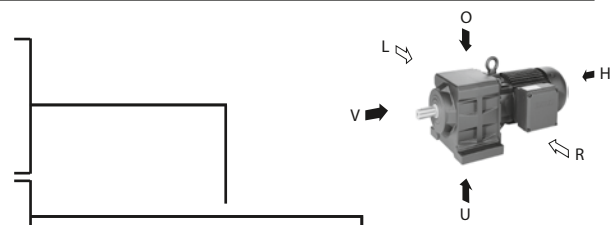

Type Designations

BF-series shaft-mounted geared motor

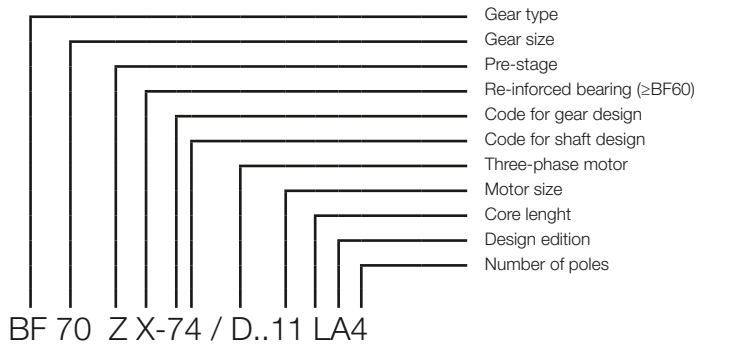

- I Gear with pre-stage
- X- Gear with re-inforced bearing
- G- Tandem gear

- 0 Cast-in torque arm

- 2 Small A-flange with clearance holes
- 3 Standard A-flange with clearance holes
- 4 Large A-flange with clearance holes

- 1 . LR Foot with clearance holes left and right
- 6 . L Foot with threaded holes, left
- 6 . R Foot with threaded holes, right
- 6 . LR Foot with threaded holes, left and right

- 7 C-flange with threaded holes
- 8 Completely machined

- . 0 Splined shaft acc. DIN 5480
- . 1 Solid shaft on gear side V
- . 2 Solid shaft on gear side H
- . 3 Solid shaft on gear side V und H
- . 4 Hollow shaft with keyway
- . 5 Hollow shaft for shrink disc SSV on gear side H
- .. W Double shaft seals
- .. A Cover for shrink disc SSV

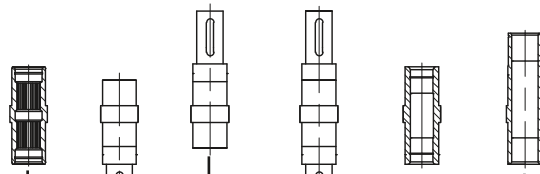
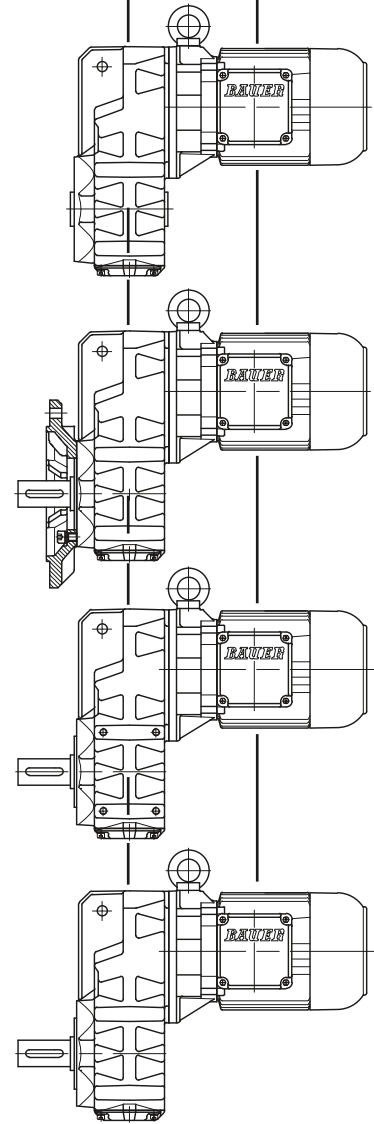
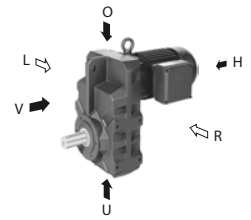

Type Designations

BK-series bevel-gear motor

3

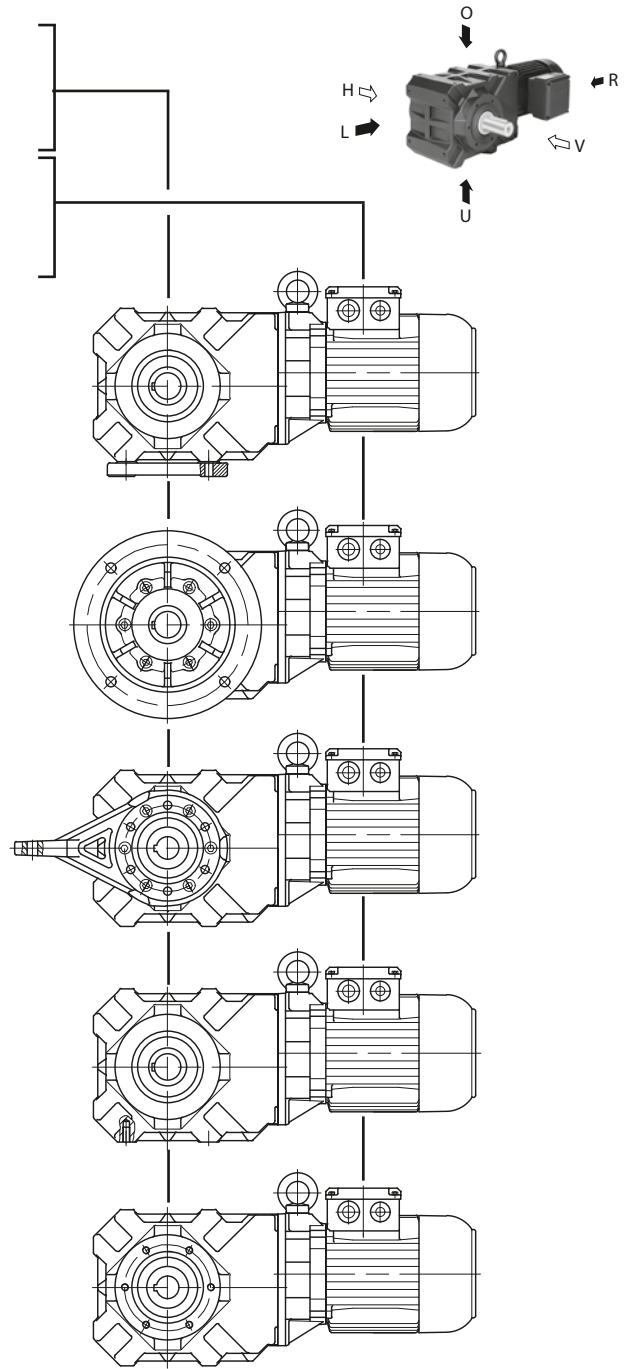
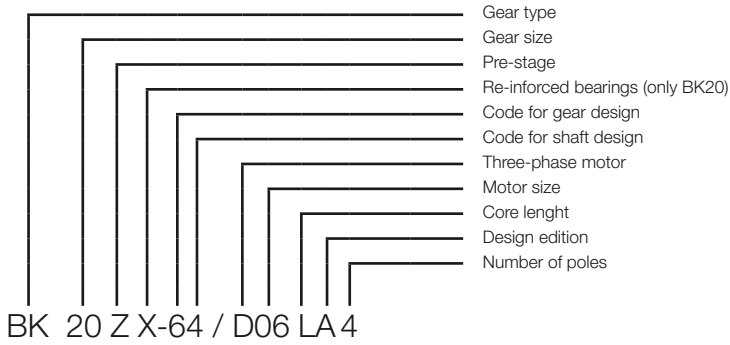

- 1 . U — Foot with clearance holes, bottom
- 1 . L — Foot with clearance holes, left
- 1 . O — Foot with clearance holes, top

- 2 . V — small A-flange with clearance holes , front
- 3 . V — Standard A-flange with clearance holes, front
- 4 . V — large A-flange with clearance holes, front
- .. H — A-flange, rear
- .. VH — A-flange, front and rear

- 5 . V — Torque arm at front
- 5 . VL — Torque arm, front to left
- 5 . VO — Torque arm, front to top
- 5 . VU — Torque arm, front to bottom
- 5 . HL — Torque arm, rear to left
- 5 . HO — Torque arm, rear to top
- 5 . HU — Torque arm, rear to bottom

- 6 . U — Foot with threaded holes, bottom
- 6 . L — Foot with threaded holes, left
- 6 . O — Foot with threaded holes, top

- 7 . V — C-flange with threaded holes, front
- 7 . H — C-flange with threaded holes, rear
- 7 . VH — C-flange with threaded holes, front and rear
- 8 . — Completely machined

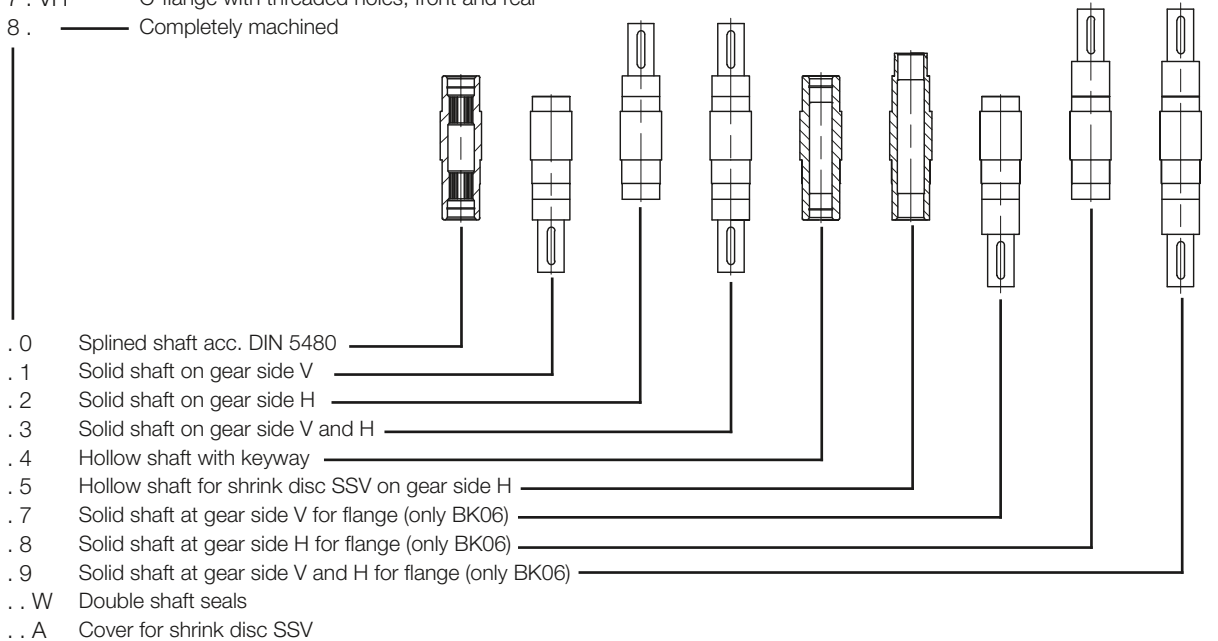

Type Designations

BS-series worm-geared motor

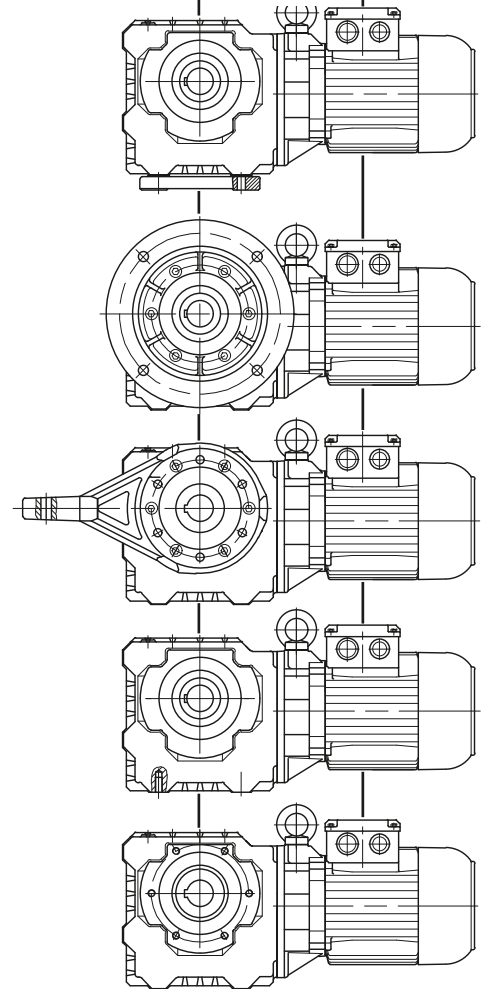
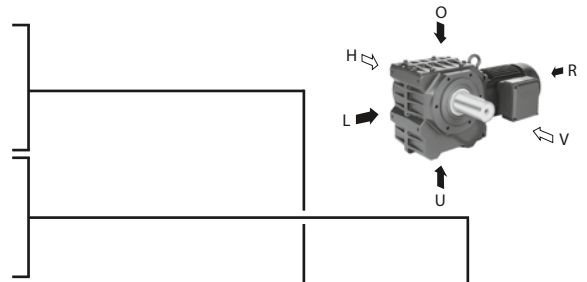

- 1 . U — Foot with clearance holes, bottom
- 1 . L — Foot with clearance holes, left
- 1 . O — Foot with clearance holes, top
- 2 . V — small A-flange with clearance holes , front
- 3 . V — Standard A-flange with clearance holes, front
- 4 . V — large A-flange with clearance holes, front
- .. H — A-flange, rear
- .. VH — A-flange, front and rear
- 5 . V — Torque arm at front
- 5 . VL — Torque arm, front to left
- 5 . VO — Torque arm, front to top
- 5 . VU — Torque arm, front to bottom
- 5 . HL — Torque arm, rear to left
- 5 . HO — Torque arm, rear to top
- 5 . HU — Torque arm, rear to bottom
- 6 . U — Foot with threaded holes, bottom
- 6 . L — Foot with threaded holes, left
- 6 . O — Foot with threaded holes, top
- 7 . V — C-flange with threaded holes, front
- 7 . H — C-flange with threaded holes, rear
- 7 . VH — C-flange with threaded holes, front and rear
- 8 . — Completely machined

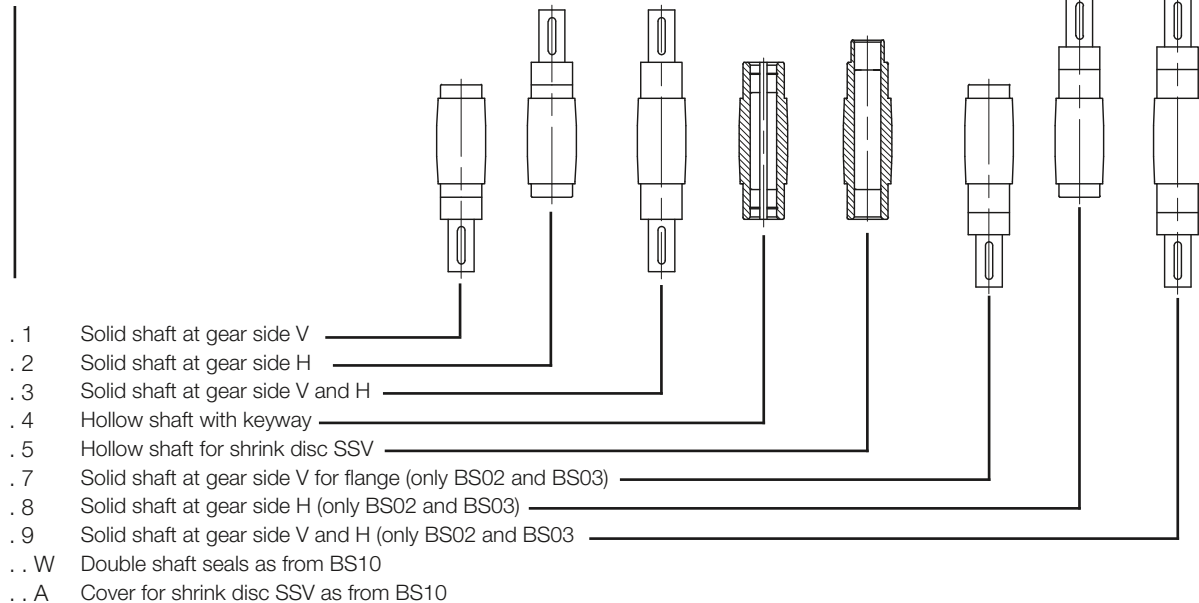

3

Type Designations

Versions and options

BG and BF series

BG series: type H4

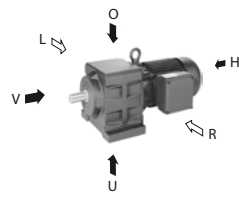

BF series: type H4

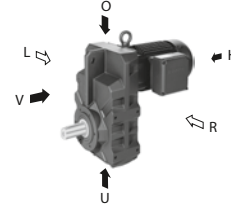

- V = Front
The side of the gear unit facing away from the motor or the source of motive power
- H = Rear
The side of the gear unit facing toward the motor or the source of motive power
- L = Left
The left side of the gear unit as viewed from the output shaft side of type B3 for the BG series or type H4 for the BF series
- R = Right
The right side of the gear unit as viewed from the output shaft side of type B3 for the BG series or type H4 for the BF series

BK and BS series

BK series: type H1

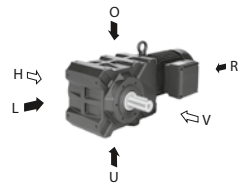

BS series: type H1

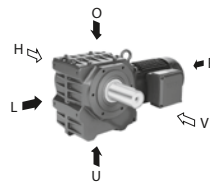

- V = Front
The side of the gear unit facing toward the viewer looking toward the type H1 unit
- H = Rear
The side of the gear unit facing away from the viewer looking toward the type H1 unit
- L = Left
The left side of the gear unit as viewed from the output shaft side of type H1, or the torque brace oriented to the left
- O = Top
The top side of the gear unit as viewed from the output shaft side of type H1, or the torque brace oriented upwards
- U = Bottom
The bottom side of the gear unit as viewed from the output shaft side of type H1, or the torque brace oriented downwards

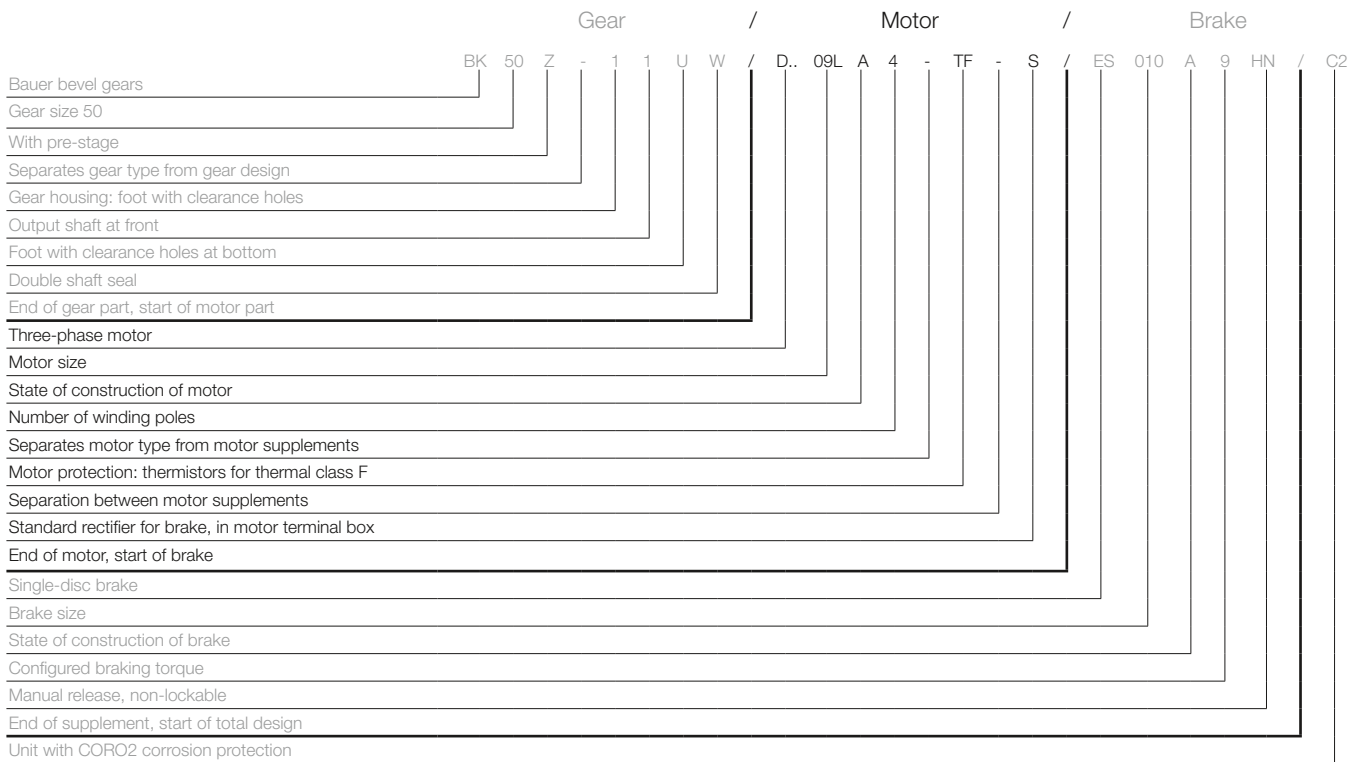

Three-phase motor

D	=	Three-phase motor
E	=	Single-phase motor (Steinmetz circuit)
S	=	PM-Synchronous motor
.	A	Aseptic motor (germ-free drive)
.	SE	Three-phase motor with enhanced efficiency compliant with IE1
.	HE	Three-phase motor with enhanced efficiency compliant with IE2
.	PE	Three-phase motor with enhanced efficiency compliant with IE3
.	N	Motor without gear unit; foot-mount version
.	NF	Motor without gear unit; flange-mount version
.	R	Roller table motor
.	XE	Explosion-proof motor with increased safety
.	XD	Explosion-proof motors
.	W	Torque motor
.	L	Special rotor for traction and slewing gear motors
.	C	With main and auxiliary windings; only with single-phase motors (EC....)
.	V	Multiple voltage ranges (wide voltage range)
.	U	Unventilated (no forced ventilation)

Motor protection

TB	=	Thermistor 140°
TF	=	Thermistor 160°
TH	=	Thermistor 180°
TEB	=	Thermistor warning/shutdown 120°/140°
TBF	=	Thermistor warning/shutdown 140°/160°
TFH	=	Thermistor warning/shutdown 160°/180°
TOB	=	Thermostatic switch, NC 140°
TOF	=	Thermostatic switch, NC 160°
TOH	=	Thermostatic switch, NC 180°
TSB	=	Thermostatic switch, NO 125°
TSF	=	Thermostatic switch, NO 160°
TSH	=	Thermostatic switch, NO 180°
TX	=	Other

Brake rectifier in motor terminal box

S	=	Standard rectifier	SG
E	=	Special rectifier	ESG
M	=	Special rectifier	MSG

Plug connector

ST	=	Harting (other)
----	---	-----------------

Heavy-duty fan

SL

Protective cover

D

CleanDrive

CD	=	Aseptic drive with cable
----	---	--------------------------

Type Designations

Motor Mounted Components

3

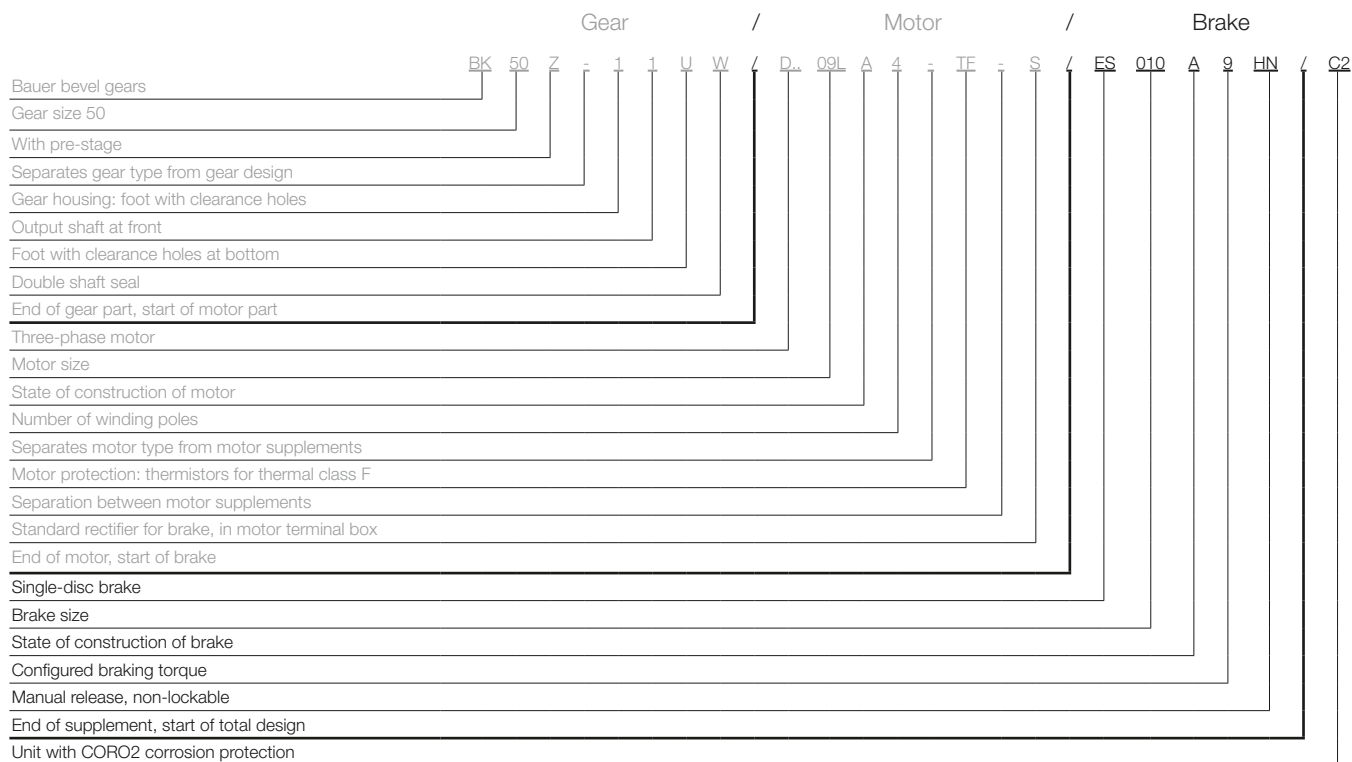

Brake

- E = Single-disc brake
- ES = Single-disc holding brake
- EH = Single-disc holding brake in heavy duty
- ZS = Two-disc holding brake
- ESX = Single-disc service brake
- EHX = Single-disc service brake in heavy duty version
- ZSX = Two-disc service brake
- ... 010 = Brake size
- A = Construction state
- 9 = Code for configured braking torque
- HN = Manual release (not lockable)
- HA = Manual release (lockable)

Reverse rotation block

- RR = Blocking direction clockwise
- RL = Blocking direction anticlockwise

Digital and analogue encoder

G

Second shaft end

- ZW = With key
- ZV = With square shaft

Forced ventilation

FV

Overall design

- AV = USA/Canada version with shaft dimensions in inches
- AM = USA/Canada version with metric shaft dimensions
- UL = US version
- CS = Canadian version
- C1 = Coro1 corrosion protection
- C2 = Coro2 corrosion protection
- C3 = Coro3 corrosion protection
- C4 = Coro4 corrosion protection
- C5I = Coro5 corrosion protection with protection level I
- C5M = Coro5 corrosion protection with protection level M
- IM2 = Protection against sea or brackish water
- SP = Non-catalogue version