

AsepticDrive™

Solutions for the Food & Beverage Industry

Main features

- Easy-to-clean design allowing cleaning agents to drain off completely
- Dirt traps are avoided
- Re-infection avoided around the motor
The fan-free design means no air turbulence occurs
- High degree of protection IP 67 as standard (optional with IP 69K)
- With acid and alkali resistant paint
- Motor windings equipped as standard with thermistors and class F insulation
- Suitable for frequency inverter duty
- Optional: solid or hollow shaft in stainless steel V4A (1.4571)

Available on request:

- Paint finish according to RAL tables
- Pre-fabricated 6 wire cable, 3 m long

Motor output

Available power ranges in continuous operation (S1):

Motor type	Power	Feature
DA05LA4	0,06 kW	
DA05LA4	0,09 kW	
DA05LA4	0,12 kW	
DA08LA4	0,25 kW	
DA08LA4	0,37 kW	according IE3
DA09LA4	0,55 kW	according IE3
DA09XA4	0,75 kW	IE3
DA09XA4	1,1 kW	IE2
DA11LA4	1,5 kW	IE3
DA11LA4	2,2 kW	IE2

An AsepticDrive™ is an asynchronous motor whose basic design dispenses with a fan and cooling ribs. The result is a motor with a completely smooth outer casing which is sealed by a matching non-drive end shield.

The AsepticDrive™ has as standard a stainless steel round connector which allows a quick and simple electrical connection of the motor. This connector contains not only the motor contacts but also those of the thermistors. The hygienic concept is also guaranteed due to the smooth surface of the connector.

The AsepticDrive™ can be easily fitted onto any gear in the BG, BF, BK or BS series, thereby catering for the majority of design requirements.

Application criteria

Special requirements regarding hygiene and cleaning are necessary in the production areas of the food and beverage industry. This is due to the sensitivity of the products and their perishable nature.

For this reason, most equipment and production machines are made of stainless steel, permitting thorough cleaning once production has ended. Stainless steel also allows the use of acid or alkali-based cleaning agents which, in combination with disinfectants, ensure that all relevant germs and bacteria are destroyed.

In the case of gear motors, which are generally mounted directly onto the machines, it has not been possible to fulfil these requirements in the past. The reasons for this are the design of the housing structures, the ribs of the motors and the fans used for cooling.

The AsepticDrive™ provides a smooth surface which can be cleaned simply and effectively without allowing any pockets of dirt to accumulate. It is also difficult for deposits to stick. The absence of a fan means above all that an inaccessible source of dirt, which like the dirt in the cooling ribs led to re-infections of the production machinery, has now been removed.

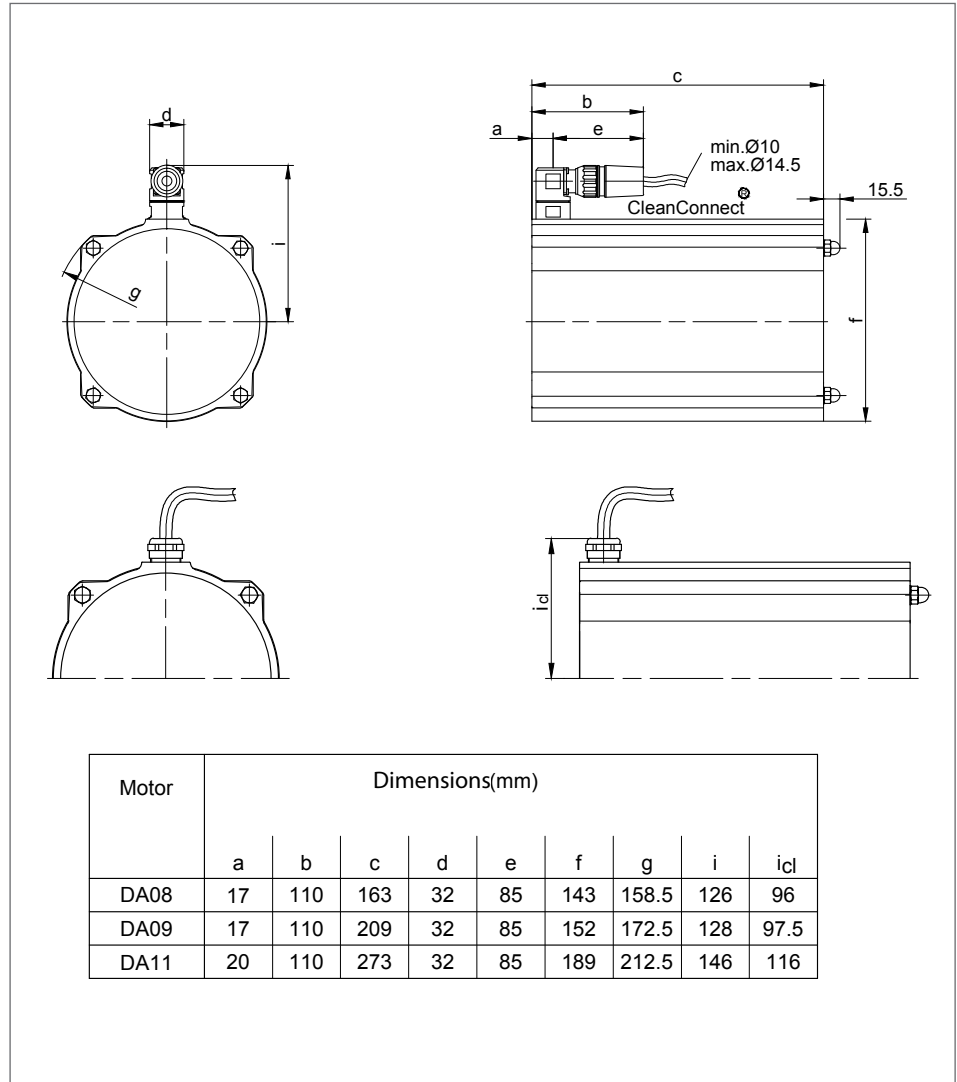

A secondary effect is that ambient and room-air infections are prevented, because any germs which form under the cowl over the weekend, for example, are not swirled around when the machinery is restarted.

To summarise, the AsepticDrive™ in combination with our new series of gears constitutes a highly effective solution for the food and beverages industry.

Bauer assumes no liability or responsibility for misprints and errors in catalogues, brochures and other printed documentation. Bauer reserves the right to make changes to products without prior notice, including to products that have already been ordered, unless contractual technical specifications are affected by such changes. All trademarks in these publications are the sole and exclusive property of the relevant companies. Bauer and the Bauer logo are trademarks of Bauer Gear Motor GmbH. All rights reserved.