

# VANE AIR MOTORS

1/2 TO 7-1/2 HP

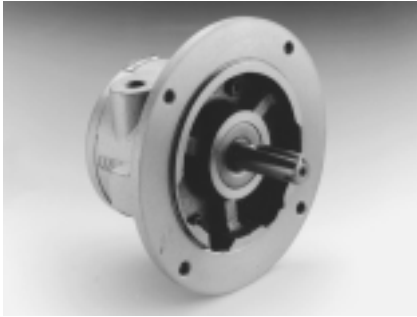

**Variable speed.** You can vary motor speed between 300 and 3,000 rpm with a simple valve in between the air source and air motor.

**Hazardous Location.** With no heat build-up, Boston Air Motors are ideal for use in flammable or explosive applications.

**Instantly reversible.\*** A four-way valve in the air line lets you reverse the air motor. A shifting of the valve changes direction—even when the air motor is running full open, you can change motor direction with a simple movement.

**Cool.** As the air motor turns, expanded air cools the motor. Units can be used in ambient temperatures up to 250°F.

**Little and light.** Get maximum horsepower with minimum size and weight.

**Little maintenance.** You can put Boston Air Motors in places where they won't get much service because there's virtually nothing to service on Boston Air Motors.

**Won't burn out.** Boston Air Motors can be stalled or overloaded for long periods of time without damage.

**No-shock starts.** Because Boston Air Motors go to work with air-cushioned smoothness they cut stress on your equipment.

**Self sealing vanes.** Vanes self-seal and self-adjust with wear, maintaining like-new output for thousands of hours of use.

**Operates in all positions.** Mount them sideways, up-side-down, or in any position so long as adequate lubrication is provided and end thrust is kept to design limits.

\*AXF-G counter clockwise only

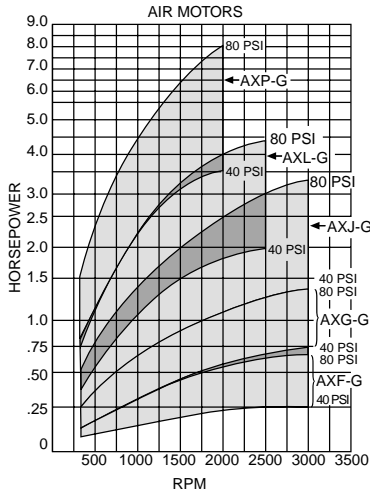

## 4 VANES COUNTER CLOCKWISE ROTATION

**AXF-G  
1/2 HP\***

\*RATED AT 80 PSIG  
1800 RPM

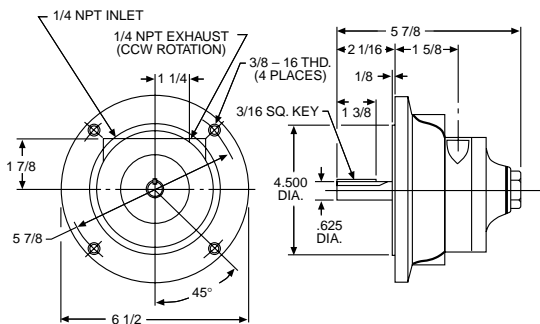

### ORDER BY CATALOG NUMBER OR ITEM CODE

Catalog Number	Item Code	NEMA Mounting
AXF-G	71478	56C

### RECOMMENDED ACCESSORIES

- Filter EN71221-MG (39914)
- Regulator EN72220-G (39928)
- Lubricator EN73220-MG (39923)
- FRL EN75221-MG (39872)
- Muffler EBB-2 (74517)

### REPAIR KIT

- AXF-G-9001 (73855)

### PERFORMANCE CHARACTERISTICS

MAXIMUM RECOMMENDED OPERATING PRESSURE: 100 PSIG  
SPEED VARIATION: 300-3000 RPM

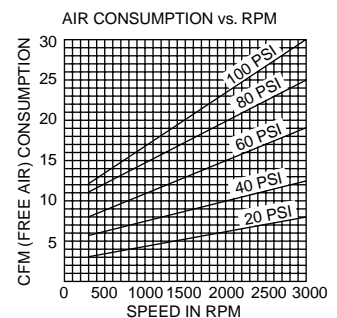
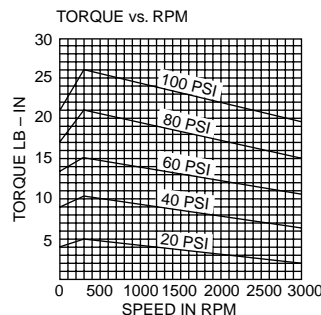

**BOSTON GEAR®**

# VANE AIR MOTORS

## 4 VANES REVERSIBLE

## AXG-G 1HP\*

\*RATED AT 80 PSIG  
1800 RPM

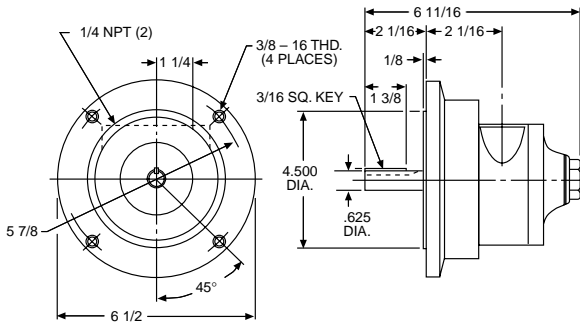

### ORDER BY CATALOG NUMBER OR ITEM CODE

Catalog Number	Item Code	NEMA Mounting
AXG-G	70720	56C

### PERFORMANCE CHARACTERISTICS

MAXIMUM RECOMMENDED OPERATING PRESSURE: 100 PSIG  
SPEED VARIATION: 300-3000 RPM

### RECOMMENDED ACCESSORIES

- Filter EN71221-MG (39914)
- Regulator EN72220-G (39928)
- Lubricator EN73220-MG (39923)
- FRL EN75221-MG (39872)
- Muffler EBB-2 (74517)

### REPAIR KIT

AXG-G-9001 (73856)

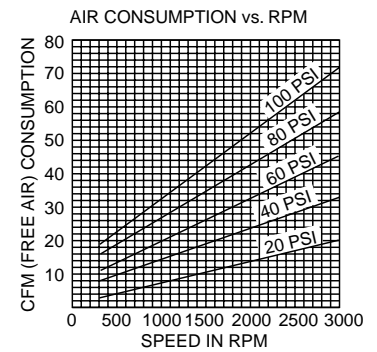
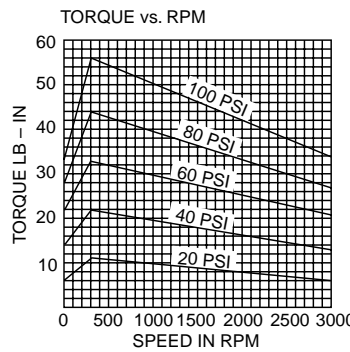

## 4 VANES REVERSIBLE

## AXJ-G 2HP\*

\*RATED AT 80 PSIG  
1800 RPM

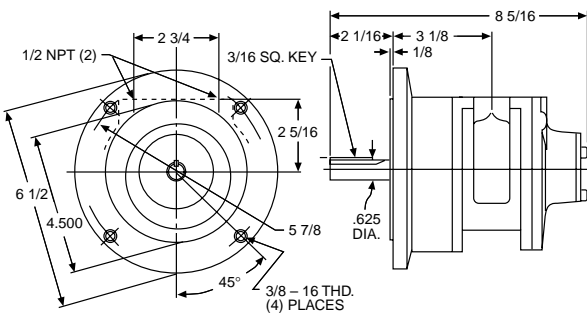

### ORDER BY CATALOG NUMBER OR ITEM CODE

Catalog Number	Item Code	NEMA Mounting
AXJ-G	70721	56C

### PERFORMANCE CHARACTERISTICS

MAXIMUM RECOMMENDED OPERATING PRESSURE: 100 PSIG  
SPEED VARIATION: 300-3000 RPM

### RECOMMENDED ACCESSORIES

- Filter EN61341-MG (70684)
- Regulator EN62340-G (70690)
- Lubricator EN63340-MG (70043)
- FRL EN65341-MG (70620)
- Muffler EBB-4 (74527)

### REPAIR KIT

AXJ-G-9001 (73857)

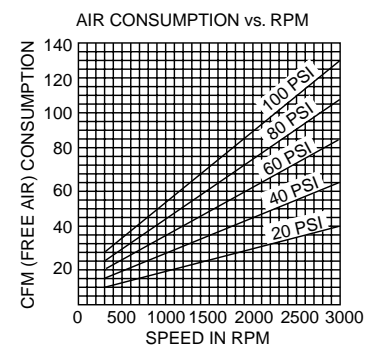
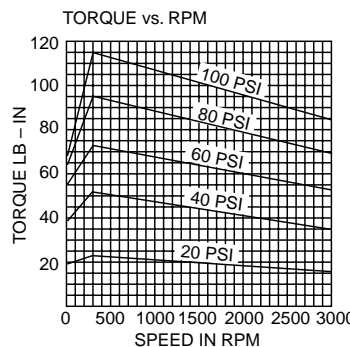

# VANE AIR MOTORS

## 4 VANES REVERSIBLE

## AXL-G 4HP

\*RATED AT 80 PSIG  
1800 RPM

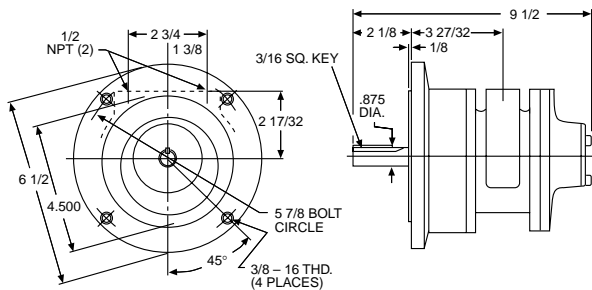

### ORDER BY CATALOG NUMBER OR ITEM CODE

Catalog Number	Item Code	NEMA Mounting
AXL-G	70722	145TC

### PERFORMANCE CHARACTERISTICS

MAXIMUM RECOMMENDED OPERATING PRESSURE: 100 PSIG  
SPEED VARIATION: 300-2500 RPM

### RECOMMENDED ACCESSORIES

- Filter EN61341-MG (70684)
- Regulator EN62340-G (70690)
- Lubricator EN63340-MG (70043)
- FRL EN65341-MG (70620)
- Muffler EBB-4 (74527)

### REPAIR KIT

AXL-G-9001 (73858)

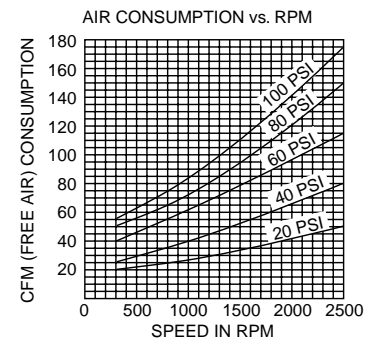
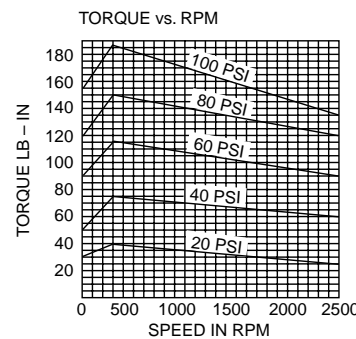

## 6 VANES REVERSIBLE

## AXP-G 7 1/2 HP\*

\*RATED AT 80 PSIG  
1800 RPM

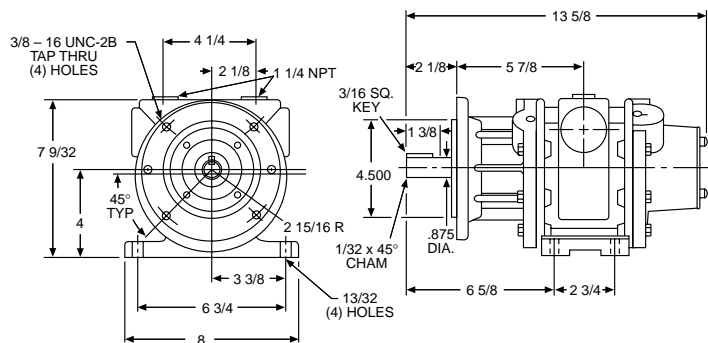

### ORDER BY CATALOG NUMBER OR ITEM CODE

Catalog Number	Item Code	NEMA Mounting
AXP-G	71477	145TC

### PERFORMANCE CHARACTERISTICS

MAXIMUM RECOMMENDED OPERATING PRESSURE: 100 PSIG  
SPEED VARIATION: 300-2000 RPM

### RECOMMENDED ACCESSORIES

- Filter EN41471-MG (73949)
- Regulator EN42470-G (74906)
- Lubricator EN43470-MG (73965)
- FRL EN45471-MG (73897)

### REPAIR KIT

AXP-G-9001 (73859)

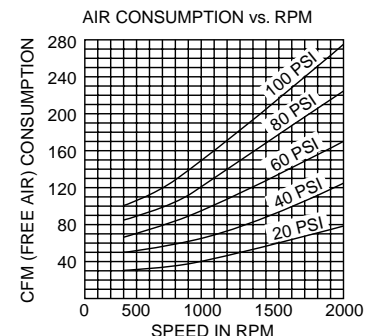
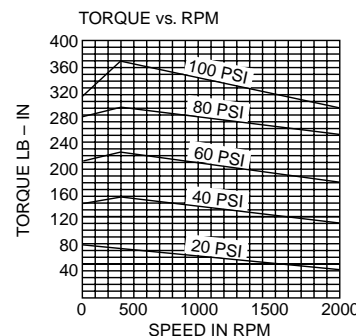

**BOSTON GEAR®**