



Section Contents

HM Series Features / How to Order	240
HM Series standard products	241
Mounting Assemblies	242
Lubrication / Operating Instructions	242-243
Helical Multiplier Ratings	244
Helical Multiplier Dimensions	245

Features / How to Order

Use alone as either a speed reducer or increaser or in combination with a 700 Series worm gear reducer to create an efficient right angle double reduction speed reducer.

- Close grained cast iron housing and flanges
- Hardened steel helical gearing for long life
- Anti-friction bearings
- Double lip seals guard against oil leakage
- Brass spring loaded breather plug keeps out dirt and water
- Optional steel bolt on base
- Double bearing design on input and output shaftt



Flanged

Unit Size	Optional Base Kits	
	Catalog Description	Item Code
1	HMF1 Base Kit	83501
2	HMF2 Base Kit	83502
3	HMF3 Base Kit	83503

Numbering System

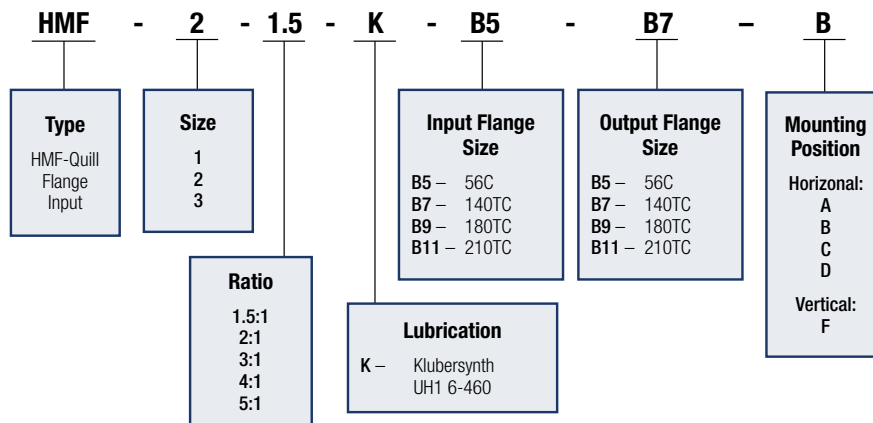

Available Styles

Model	Input	Output
HMF1	B5	B5
HMF 2	B5	B5
	B5	B7
	B7	B7
HMF3	B9	B9
	B9	B11
	B11	B9
	B11	B11

Helical Multiplier Series Reducer

NEMA C-Face Models

Catalog Number	Item Code
HMF1-1.5K-B5-B5	F05001
HMF1-2K-B5-B5	F05002
HMF1-3K-B5-B5	F05003
HMF1-4K-B5-B5	F05004
HMF1-5K-B5-B5	F05005
HMF2-1.5K-B5-B5	F05006
HMF2-1.5K-B5-B7	F05007
HMF2-1.5K-B7-B5	F05008
HMF2-1.5K-B7-B7	F05009
HMF2-2K-B5-B5	F05010
HMF2-2K-B5-B7	F05011
HMF2-2K-B7-B5	F05012
HMF2-2K-B7-B7	F05013
HMF2-3K-B5-B5	F05014
HMF2-3K-B5-B7	F05015
HMF2-3K-B7-B5	F05016
HMF2-3K-B7-B7	F05017
HMF2-4K-B5-B5	F05018
HMF2-4K-B5-B7	F05019
HMF2-4K-B7-B5	F05020
HMF2-4K-B7-B7	F05021
HMF2-5K-B5-B5	F05022
HMF2-5K-B5-B7	F05023
HMF2-5K-B7-B5	F05024
HMF2-5K-B7-B7	F05025

Catalog Number	Item Code
HMF3-1.5K-B11-B11	F05026
HMF3-1.5K-B11-B9	F05027
HMF3-1.5K-B9-B11	F05028
HMF3-1.5K-B9-B9	F05029
HMF3-2K-B11-B11	F05030
HMF3-2K-B11-B9	F05031
HMF3-2K-B9-B11	F05032
HMF3-2K-B9-B9	F05033
HMF3-3K-B11-B11	F05034
HMF3-3K-B11-B9	F05035
HMF3-3K-B9-B11	F05036
HMF3-3K-B9-B9	F05037
HMF3-4K-B11-B11	F05038
HMF3-4K-B11-B9	F05039
HMF3-4K-B9-B11	F05040
HMF3-4K-B9-B9	F05041
HMF3-5K-B11-B11	F05042
HMF3-5K-B11-B9	F05043
HMF3-5K-B9-B11	F05044
HMF3-5K-B9-B9	F05045

Helical Multiplier Lubrication

Horizontal Mounting

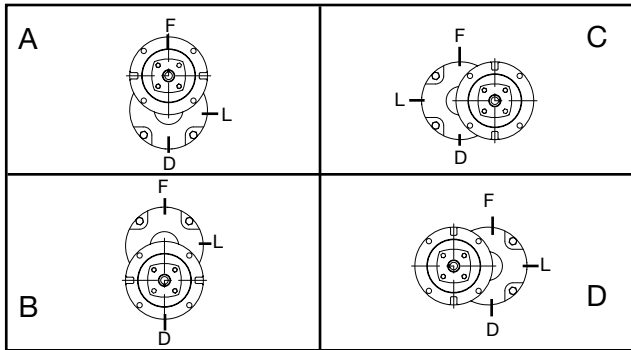

Vertical Mounting

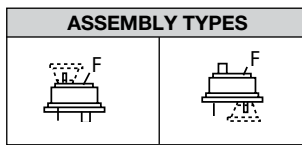

Recommended Lubricants

The following tables indicate the type and viscosity of lubricant suitable for reducers operating at various temperatures.

Lubrication and maintenance instructions are provided with each speed reducer. These instructions should be followed for best results. It is important that the proper type of oil be used since many oils are not suitable for the lubrication of gears. Various types of gearing require different types of lubricants.

The lubricant must remain free from oxidation and contamination by water or debris since only a very thin film of oil stands between efficient operation and failure. To assure long service life, the reducer should be periodically drained (preferably while warm) and refilled to the proper level with a recommended gear oil. Under normal environmental conditions oil changes, are suggested after the initial 250 hours of operation, and thereafter, at regular intervals of 2500 hours or every 6 months. Synthetic lubricants will allow extended lubrication intervals due to its increased resistance to thermal and oxidation degradation. It is suggested that the initial oil change be made at 1500 hours and, thereafter, at 5000 hour intervals.

During the initial period of operation, higher than normal operating temperatures may be seen. This is due to the initial break-in of the gear set. The temperature of Helical Gear Reducers may reach 160°F.

Enclosed Helical

Recommended Oil (or equivalent)	Viscosity Range S&S @ 100°F	Oil Type	ISO Viscosity Grade No.
Klubersynth* UH1 6-460	1950/2500	PAG	460
Mobile SHC634	1950/2500	PAO	320/460

Ambient temperature range of -20F to +125F is suitable for standard configured products and ratings. Contact technical support for operating conditions beyond this range.

Recommended Lubricant	Boston Gear Item Code
	Quart
Klubersynth UH1 6-460	65159
Mobile SHC634	51493

CAUTION: Relubricate more frequently, if drive is operated in high ambient temperatures or unusually contaminated atmospheres. High loads and operating temperatures will also require more frequent relubrication.

*Synthetic recommendation is exclusively for Klubersynth UH1 6-460.

‡The UH1 6-460 lubricant will perform at temperatures considerably higher than 225°F. However, the factory should always be consulted prior to operating at higher temperatures, as damage may occur to oil seals and other components.

Drain Plug must be installed in the lower most location of the housing. This plug will be on the input shaft side of the housing for positions B, C, D and A, may be either side for A.

The **Vented Filler Plug** should be installed in the uppermost location. This plug will be on the input shaft side for positions A, C, or D, on either side for B and must be tightened into position.

Level Plug position will be as indicated for horizontal positions. For vertical positions the oil level is established by an oil level distance measured from the outer surface of the housing from the oil filler hole.

Size	Flanged		Non-Flanged	
	Weight (lbs.)	Capacity (ozs)	Weight (lbs.)	Capacity (ozs)
1	18	11	14	11
2	25	14	21	14
3	50	28	43	28

Installation, Lubrication and Operation Instructions

Warning: *Boston Gear speed reducers are normally shipped without lubricant. They must be filled to the proper level with the recommended lubricant before operation.*

These instructions must be read thoroughly before installing or operating speed reducers. File instructions for future reference.

CAUTION

- For safe operation of any gear drive, all rotating shafts and auxiliary components must be shielded to conform with applicable safety standards. You must consider overall operational system safety at all times.
- When using a gear drive to raise or lower a load, such as in hoisting applications, provision must be made for external braking. Under no conditions should a speed reducer be considered self-locking.
- Mounting of speed reducers in overhead positions may be hazardous. Use of external guides or supports is strongly recommended for overhead mounting.

General Instructions

1. When mounting, use maximum possible bolt size and secure gear drive to a rigid foundation. Periodic inspection of all bolts is recommended.
2. Align all shafts accurately. Improper alignment can result in failure. Use of flexible couplings is recommended to compensate for slight misalignment.
3. Arrange the drain and breather plug per your mounting position as indicated on page 230. The breather plug should also be located in the Fill position.
4. Auxiliary drive components (such as sprockets, gears and pulleys) should be mounted on the shafts as close as possible to the housing to minimize effects of overhung loads. Avoid force fits that might damage bearings or gears.
5. Gear drives are nameplated for 1750 RPM Input Speed and Class I Service. For lower Input Speeds and other Service Class, refer to catalog rating information.
6. Input speeds of 1750 and lower are shown in catalog rating tables for speed reducing applications. This does not represent the maximum speed. Since speed limitation is based on pitching velocity and varies with size and ratio.

Instructions for Flanged Models

HMF (Quill Type Input)

1. Assemble the key to the motor shaft and coat the quill bore with anti-seize compound. Insert the motor shaft into the reducer input shaft.
2. Rotate the motor to proper position and firmly secure to flange with four hex-head cap screws.

CAUTION - If the motor does not readily seat itself, check to determine if key has moved axially along motor shaft, causing interference. Staking of the keyway adjacent to the motor key will facilitate this procedure.

Location of Filler, Level and Drain Plugs

Helical-Multiplier reducers may be mounted in any position shown.

Filler, level and drain plugs are completely interchangeable and should be arranged to suit the required mounting positions.

Helical Multiplier Series Ratio & Capacity Selection Tables

Horsepower and Torque Capacities (Service Factor 1.0)

Series Size			HMF Size 1			HMF Size 2			HMF Size 3		
Ratio	Input RPM	Output RPM	Input HP	Output		Input HP	Output		Input HP	Output	
				HP	Torque (Lb. In.)		HP	Torque (Lb. In.)		HP	Torque (Lb. In.)
1.5	1750	1167	3.29	3.19	172	13.60	13.19	712	17.79	17.26	932
2	1750	875	2.74	2.66	192	11.76	11.41	822	15.38	14.92	1075
3	1750	583	2.06	2.00	216	9.48	9.20	944	12.39	12.02	1299
4	1750	437	1.45	1.41	203	6.88	6.67	962	8.99	8.72	1258
5	1750	350	1.05	1.02	183	5.06	4.91	884	6.61	6.41	1155

Output Shaft Thrust Rating (lbs.)

	1.5:1	2:1	3:1	4:1	5:1
HMF1	153	169	193	213	230
HMF2	230	253	289	319	345
HMF3	313	345	394	435	470

Overhung Loads (lbs.)

	HMF Size 1	HMF Size 2		HMF Size 3	
Input	200	200		350	
Output	315	B5 375	B7 750	B9 1100	B11 1135

Ratings Shown Reflect Maximum Gear Capacity With KLUBERSYNTH UH1 6-460 Lubricant.

Overhung Load is at centerline of output shaft projection and with NO THRUST Load.

Maximum Input Speed 1750 RPM

Helical Multiplier Dimensions

HMF Basic

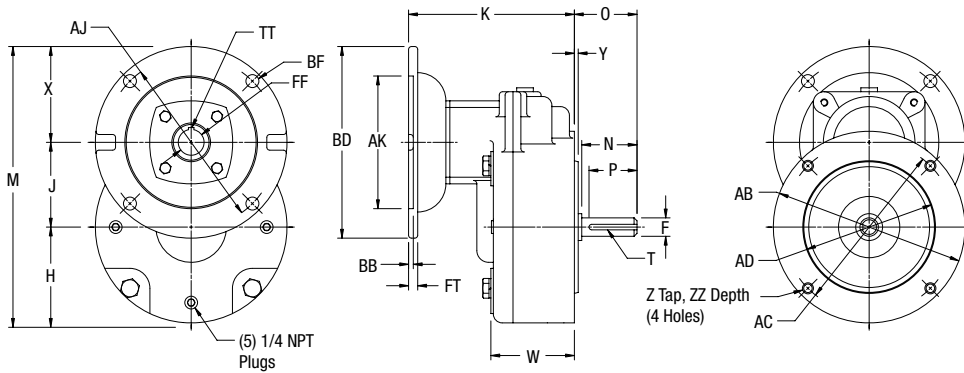

HMF with Base

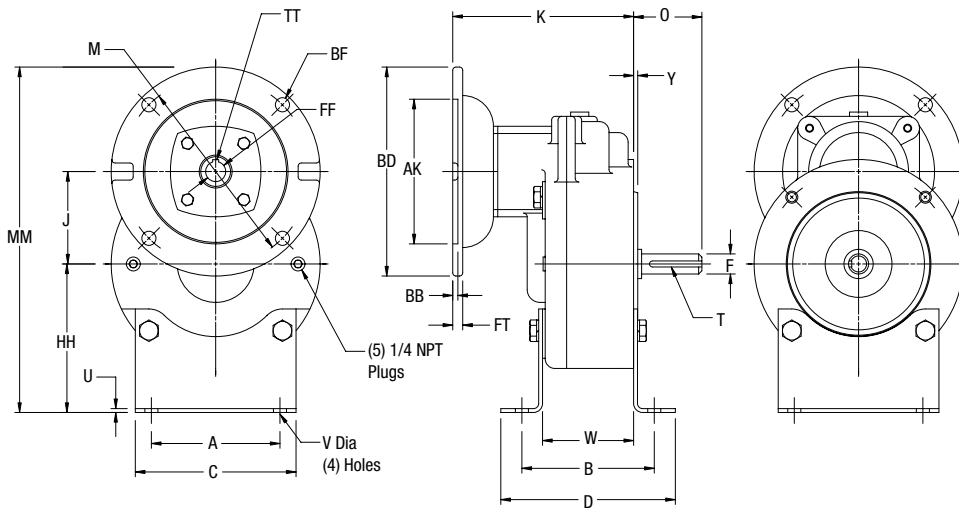

ALL DIMENSIONS IN INCHES

Size	Output Flange	Foot				Main Dimensions										
		A	B	C	D	F	H	HH	J	K	M	MM	N	O	P	T
1	B5	4.00	3.87	5.00	5.18	0.625	2.39	4.62	1.675	4.19	7.31	9.54	1.89	2.04	1.57	3/16X3/32
	B5	4.00	4.12	5.00	5.44	0.625	3.37	4.62	2.875	5.00	9.49	10.74	1.84	1.90	1.57	3/16X3/32
2	B7	4.00	4.12	5.00	5.44	0.875	3.37	4.62	2.875	5.00	9.49	10.74	1.84	1.90	1.57	3/16X3/32
	B9	5.13	4.74	6.37	6.15	1.125	4.25	4.81	2.875	6.44	11.63	12.19	2.50	3.31	1.97	1/4X1/8
3	B11	5.13	4.74	6.37	6.15	1.375	4.25	4.81	2.875	6.44	11.63	12.19	2.50	3.31	1.97	5/16X5/32

Size	Main Dimensions					Output Flange					
	U	V	W	X	Y	Z	ZZ	AB	AC	AD	
1	0.12	0.406	1.95	3.25	0.16	3/8 - 16	Thru	6.5	5.875	4.5	
2	0.12	0.406	3.00	3.25	0.16	3/8 - 16	0.75	6.5	5.875	4.5	
3	0.16	0.500	3.35	4.50	0.31	1/2 - 13	Thru	--	7.250	8.5	

Size	Input Flange	Input Flange							
		AJ	AK	BD	BF	BB	FF	FT	TT
1	B5	5.875	4.5	6.5	0.43	0.16	0.625	0.35	3/16x3/32
	B5	5.875	4.5	6.5	0.41	0.16	0.625	0.43	3/16x3/32
2	B7	5.875	4.5	6.5	0.41	0.16	0.875	0.43	3/16x3/32
	B9	7.250	8.5	9.0	0.59	0.24	1.125	0.59	1/4x1/8
3	B11	7.250	8.5	9.0	0.59	0.24	1.375	0.59	5/16x5/32

