

# Varitorque Pneumatic Overload Clutches VOR Series

---



## Section Contents

FEATURES .....	70
OPERATING PRINCIPLES .....	70
SELECTION .....	71
HOW TO ORDER.....	71
RATINGS AND DIMENSIONS .....	72
GENERAL INFORMATION .....	73

# Varitorque Pneumatic Overload Clutches VOR Series

## Features

- “In Flight” torque control. Precise torque control adjustable for starting and overrunning loads
- Single positioning for re-engagement at the exact cycle point at which it released
- Torque accuracy within  $\pm 5\%$
- Bi-directional operation
- Electroless nickel finish
- Six point drive engagement
- Automatic disconnect
- Deublin flange mounted air union
- Automatic switch actuating plate for instantaneous remote detection of overload condition
- Completely enclosed for “dirty” applications
- Pressure lubrication
- Positive split locking collar for secure shaft mounting
- Operates on static air pressure (20-80 psi), no elaborate air systems required

## Operating Principles

### Air Union

The air pressure supplied to the clutch enters through the hex steel rotor of the Deublin air union. When the VOR Series VariTorque is engaged and operating, the union rotor is the only stationary part. The union housing rotates on a double row ball bearing protected by dirt-tight seals. A spring-loaded carbon micro-lapped seal prevents air leakage between the rotor and housing of the union. The air passes through the union housing into the cylinder assembly of the VariTorque.

### Cylinder Assembly

Air pressure acts against the surface area of the piston exerting a force to move the piston against the pressure pins. Resulting torque ranges are developed by different size piston surface areas of the two cylinder sizes, (L-small, H-large).

The switch actuating plate moves with the piston. It is directly connected to the piston through the cylinder housing via trip pins and trip plate bolts. The plate’s lateral motion can be used to actuate a limit switch signaling an overload condition.



The valve assembly located through the piston serves two purposes. The first is to provide the single position engagement of the clutch. The piston will not be energized until the valve is seated in its cam seat located on the end of the rotor. This ensures that the rotor and cylinder-housing assembly always engage in the same relative position. The second purpose of the valve assembly is to relieve cylinder air pressure by allowing it to escape through the air exhaust muffler upon overload.

### Piston Springs

Once the valve is seated in its single home position, the clutch can be engaged. Air pressure forces the piston against the three piston springs. These springs serve to move the piston and switch actuating plate out when the clutch overloads or the air pressure is shut off to the clutch.

### Housing Assembly

The force from the piston is transmitted to six pressure pins. Six pawls equally spaced around the rotor are forced by the pressure pins to engage into six notches in the rotor barrel. The pressure pins, pawls and rotor are made of alloy steel and are electroless nickel plated for long life.

When the set torque limit in the VariTorque is exceeded, the pawls are forced out of the notches in the rotor barrel. They in turn push the pressure pins and piston. When the rotor turns in relation to the housing-cylinder assembly, the valve rides up the ramp of the cam seat and relieves the cylinder air pressure. The rotor now can rotate freely, independent of the housing assembly on two sealed ball bearings.

# Varitorque Pneumatic Overload Clutches VOR Series

## Selection

- Determine the overload release torque by one of these methods:
  - Use the torque formula with horsepower and RPM specific to the selected clutch location. A service factor may be required for high inertia starts, reversing or peak load conditions, (refer to Page 98 for service factor information. For average applications, a service factor "SF" of 1.25 is recommended):
 
$$\text{Torque (Lb. In.)} = \frac{\text{HP} \times 63025}{\text{RPM}} \times \text{SF}$$
  - Determine the "weak link" in the drive, (i.e. chain, reducer, belt or shaft). Select an overload release torque below the "weak link's" maximum torque rating.
  - Physically measure the drive torque with a torque wrench and size accordingly.
- Determine the bore size and keyway.
- Determine the approximate start-up and running air pressures for the application.
- Refer to the Basic Selection Chart for the appropriate clutch size.
- Refer to Page 72 for ratings and dimensions.
- Refer to Page 97 for recommended mounting locations.

**Figure 1**  
Air pressure and torque capacity

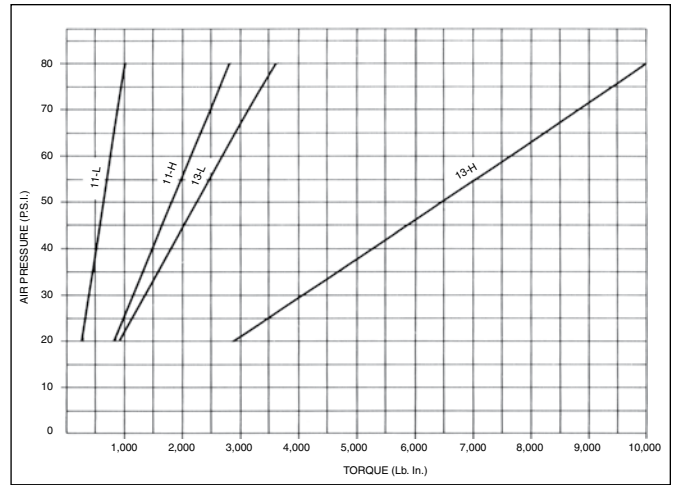

**Basic Selection Chart**

Clutch Size	Maximum Bore (In.)*	Torque Code	Torque Range (Lb. In.)	Maximum RPM
11	1.3125	L	250-1,000	1,000
	1.2500	H	800-2,800	
13	2.1875	L	900-3,600	1,000
	2.0000	H	2,800-10,000	

\*Larger bores may require flat keys (supplied with unit).

## VOR Series Part Numbering System

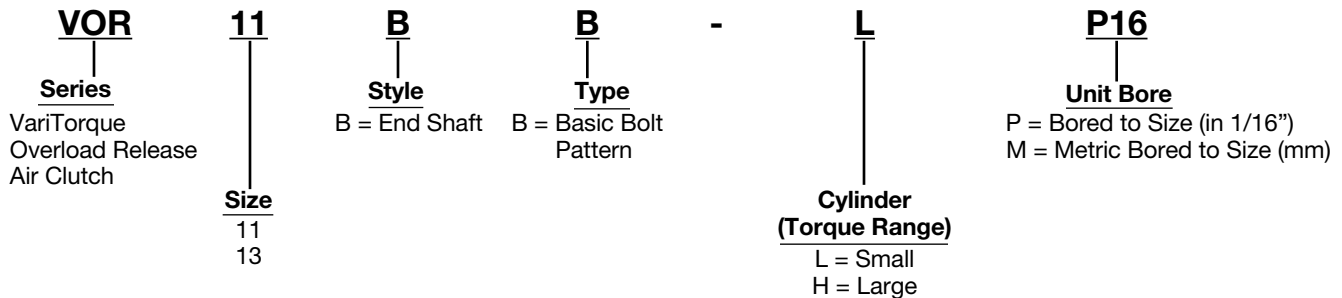

## How to Order

When ordering a VOR Series VariTorque Overload Clutch, please include code letters/numbers for series, size, style, type, torque range, and unit bore.

### Example:

Required Size, 11 VOR Series Overload Clutch, end shaft mount, basic type, small torque range, with a one inch bore:



# Varitorque Pneumatic Overload Clutches VOR Series

## Style B

### Type B Basic Sprocket Mounting

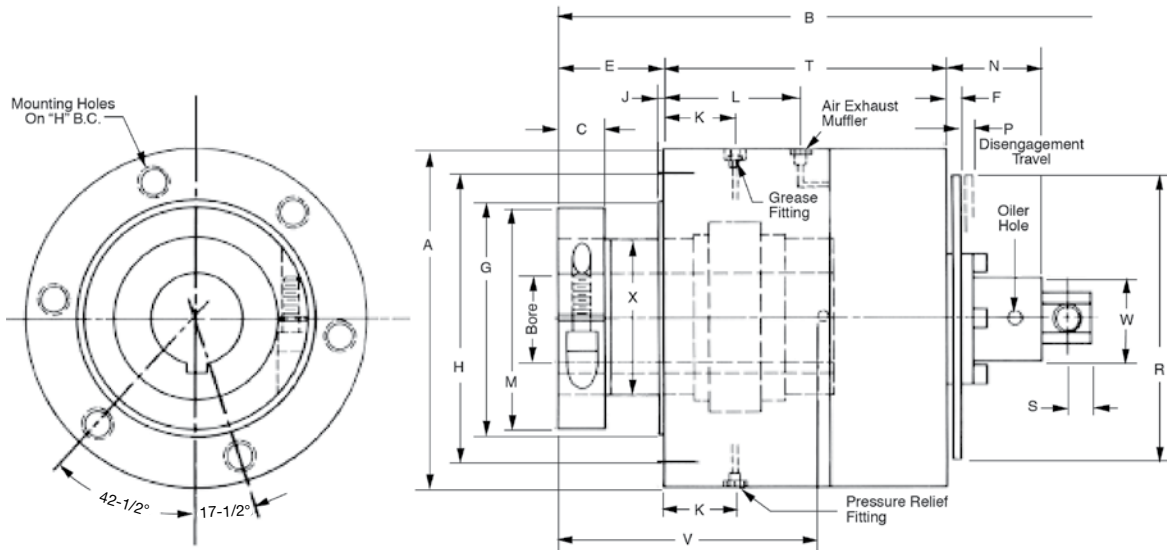

All Dimensions in Inches

Clutch Size	A	B	C	E	F	G ±.001	H Bolt Center	J	K	L	M	N	P	R	S	T	V	W	X +.0000 -.0005	Mounting Holes	
																				Qty.	Thread Size
11	4.75	9.03	.68	1.50	.21	2.748	3.500	.06	0.96	1.69	2.75	2.19	.13	4.75	.44	4.42	3.03	1.62	1.7722	6	5/16-18
13	6.50	10.19	.87	2.00	.21	4.498	5.500	.06	1.38	2.62	4.00	1.81	.16	6.50	.44	5.44	4.47	1.62	2.7565	6	5/8-11

### Ratings

Clutch Size	Torque Code	Torque Range (Lb.-In.)	Max. RPM	Air Inlet (NPT)	WR2 (Lb.-In.2)	Weight (Lbs.)
11	L	250-1,000	1,000	1/4	45.7	17
	H	800-2,800			46.5	18
13	L	900-3,600	1,000	1/4	197	39
	H	2,800 - 10,000			212	41

### Clutch Bores

Clutch Size	Torque Range	Bores (inch)	
		Max. (1)	Max. (2)
11	L	1.1875	1.3125
	H	1.1875	1.2500
13	L	1.7500	2.1875
	H	1.7500	2.0000

Refer to Page 96 for a complete list of bore codes.

- (1) Square Key
- (2) Flat Key

Refer to Page 71 for ordering information.

# Varitorque Pneumatic Overload Clutches

## General Information

### Limit Switch

In the layout in Figure 2 the limit switch should be wired in its normally closed condition. The switch is used to open the circuit to the motor during a torque overload condition. The switch should be wired in parallel with the JOG button so the drive may be started in the event the VariTorque clutch has stopped with the limit switch circuit in an open state.

### Air Controls

The HIGH pressure regulator should be set at a pressure just HIGH enough to permit the VariTorque clutch to overcome any momentary overload torques caused during the machine's start-up and stopping period.

The LOW pressure regulator should be set at a pressure just LOW enough to permit the VariTorque clutch to overcome the normal operating torques caused during the machines running period and to permit a crisp and positive re-engagement of the VariTorque clutch should an overload occur.

### Indirect Drives

The VariTorque overload release air clutch is utilized in conjunction with chain sprockets or belt driven sheaves. For chain and sprocket applications smaller than those shown in the table below or belt driven sheave applications, consult with the factory. In most cases, a minor modification of the VariTorque design or the sprocket/sheave will permit usage.

### Special Finishes

All VariTorque clutches are supplied with an electroless nickel finish. Special coatings, finishes or paints are also available.

### Custom Variations

- Sprockets or sheaves supplied and mounted
- Dimensional changes (i.e. overall length, actuating plate diameters)
- Bores and keyways (i.e. metric, non-standard)
- Special adaptations

Figure 2

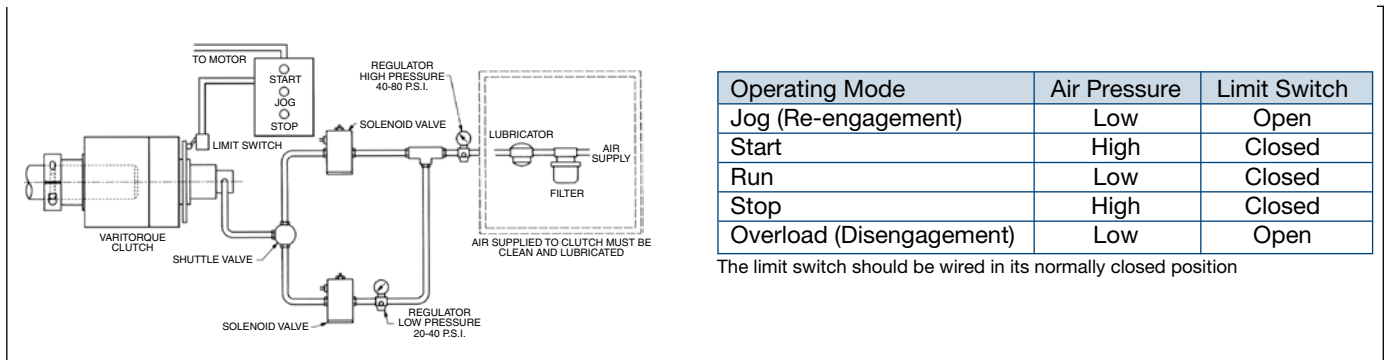

Refer to Boston Gear's Fluid Power Products Catalog for air preparation and control products.

### Minimum Acceptable Plate Sprocket Mounts

Clutch Size	Chain Size and Pitch									
	#35 3/8 Pitch	#40 1/2 Pitch	#41 1/2 Pitch	#50 5/8 Pitch	#60 3/4 Pitch	#80 1 Pitch	#100 1-1/4 Pitch	#120 1-1/2 Pitch	#140 1-3/4 Pitch	#160 2 Pitch
11	45	34	35	28	24	19	16	14	12	—
13	60	45	45	36	31	24	20	17	16	14

Boston Gear will also supply and mount sprockets or sheaves, as specified, for a complete package.

