

### ADJUSTABLE SPEED DRIVES – WHAT THEY ARE, HOW THEY WORK

The primary function of any adjustable speed drive is to control the speed, torque, acceleration, deceleration and direction of rotation of a machine. Unlike constant speed systems, the adjustable speed drive permits the selection of an infinite number of speeds within its operating range.

Most multi-purpose production machines benefit from adjustable speed control, since frequently their speeds must change to optimize the machine process or adapt it to various tasks for improved product quality, production speed or safety. Lathes and other machine tools run small diameter work pieces at high speed and large diameter pieces at low speeds to optimize the feed rate into the cutting tool. A printing press is operated at the speed that produces the best quality product, which may vary greatly with the weight and coating of paper, and the characteristics of the inks used. Also, the controlled acceleration provided by an adjustable speed drive allows the press to accelerate smoothly to prevent breaking the web of paper. A pump supplying water in a high rise building may run at very slow speeds at 3 o'clock AM to maintain system pressure, but be called upon at 3 o'clock PM to run at high speeds to provide high flow rates necessitated by water usage by the inhabitants.

While early types of adjustable speed drives based upon mechanical and hydraulic principles still remain in limited usage, the overwhelming choice today for industrial applications is the electrical adjustable speed drive. No other type offers the combined benefits of high performance, high efficiency, low maintenance, versatility and moderate initial cost. Electrical adjustable speed drives are offered in a number of basic types, but the two most versatile for general purpose applications and therefore the most common, are direct current (DC drives) and adjustable frequency (AC drives) as manufactured by Boston Gear. Electrical adjustable speed drives typically consist of three principle elements, as shown by the system block diagram in Figure 1.

### 1. OPERATOR CONTROL STATION – THE BOSS

Allows the operator to start and stop the drive controller by push buttons or switches, and set the motor speed by turning a potentiometer to the desired dial setting. Operator controls may be integrated into the controller or mounted remotely from the drive controller.



### 2. DRIVE CONTROLLER – THE BRAINS

Converts the fixed voltage and frequency of the alternating current (AC) plant power source into an adjustable power output to control the drive motor over a wide speed range. The output is established by the speed control potentiometer. The controller includes sensing circuits to hold or regulate the motor at the desired speed with variations in the source voltage and changes in motor load. The controller also includes protective circuitry and devices to prevent damage from overloads, power source transients and output power faults.



### 3. DRIVE MOTOR – THE MUSCLE

Translates electrical energy into mechanical motion. The output is a shaft rotation (RPM), which varies in proportion to the power applied by the drive controller. The motor shaft is normally coupled to a gear reducer or other mechanical power transmission device to further reduce the motor speed to a level useable by the driven machine.

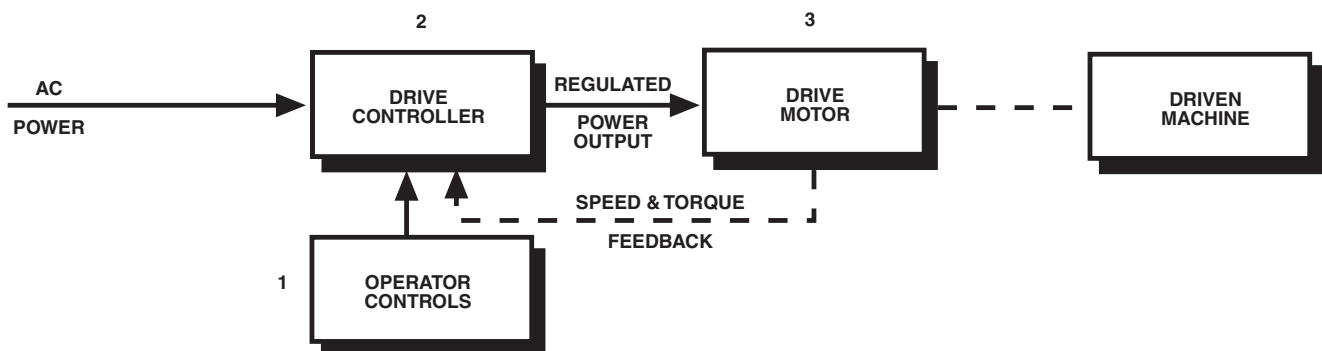

FIGURE 1.

# APPLICATION ENGINEERING

## AC & DC Controllers

### DC DRIVES – PRINCIPLES OF OPERATION

DC drives, because of their simplicity, ease of application, reliability and favorable cost remain the backbone of industrial applications. A typical adjustable speed drive using a silicon controller rectifier (SCR) power conversion section, common for this type unit, is shown in Figure 2. The SCR, (also termed a thyristor) power converter converts the fixed voltage alternating current (AC) of the power source to an adjustable voltage, controlled direct current (DC) output which is applied to the armature of a DC motor.

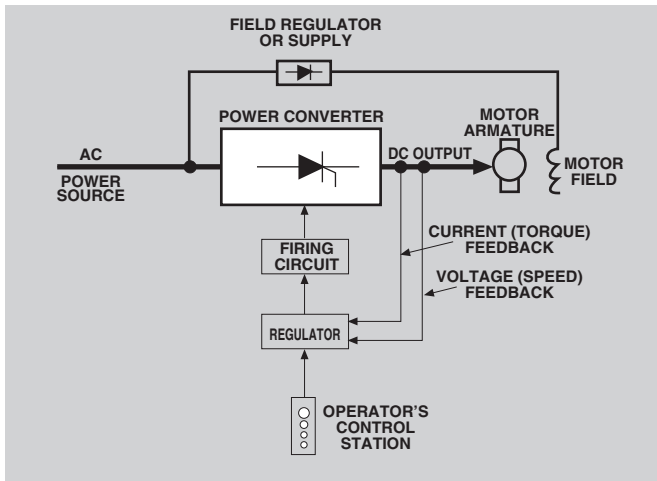

FIGURE 2. TYPICAL DC DRIVE

SCR's provide a controllable power output by "phase angle control", so called because the firing angle (a point in time where the SCR is triggered into conduction) is synchronized with the phase rotation of the AC power source. If the device is triggered early in half cycle, maximum power is delivered to the motor; late triggering in the half cycle provides minimum power, as illustrated by Figure 3. The effect is similar to a very high speed switch, capable of being turned on and "conducted" off at an infinite number of points within each half cycle. This occurs at a rate of 60 times a second on a 60 Hz line, to deliver a precise amount of power to the motor. The efficiency of this form of power control is extremely high since a very small amount of triggering energy can enable the SCR to control a great deal of output power.

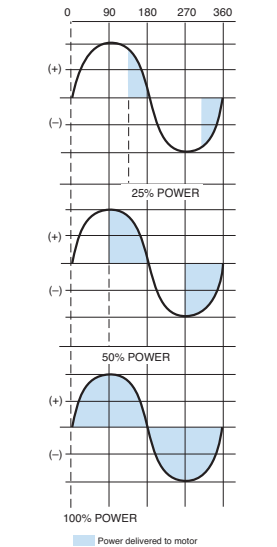

FIGURE 3. TRIGGERING POINTS FOR VARIOUS POWER OUTPUTS

### DC DRIVE TYPES

**Nonregenerative DC Drives**—Nonregenerative DC drives are the most conventional type in common usage. In their most basic form they are able to control motor speed and torque in one direction only as shown by Quadrant I in Figure 4. The addition of an electromechanical (magnetic) armature

reversing contactor or manual switch permits reversing the controller output polarity and therefore the direction of rotation of the motor armature as illustrated in Quadrant III. In both cases torque and rotational direction are the same.

**Regenerative DC Drives**—Regenerative adjustable speed drives, also known as four-quadrant drives, are capable of controlling not only the speed and direction of motor rotation, but also the direction of motor torque. This is illustrated by Figure 4.

The term regenerative describes the ability of the drive under braking conditions to convert the mechanical energy of the motor and connected load into electrical energy which is returned (or regenerated) to the AC power source.

When the drive is operating in Quadrants I and III, both motor rotation and torque are in the same direction and it functions as a conventional nonregenerative unit. The unique characteristics of a regenerative drive are apparent only in Quadrants II and IV. In these quadrants, the motor torque opposes the direction of motor rotation which provides a controlled braking or retarding force. A high performance regenerative drive, is able to switch rapidly from motoring to braking modes while simultaneously controlling the direction of motor rotation.

A regenerative DC drive is essentially two coordinated DC drives integrated within a common package. One drive operates in Quadrants I and IV, the other operates in Quadrants II and III. Sophisticated electronic control circuits provide interlocking between the two opposing drive sections for reliable control of the direction of motor torque and/or direction of rotation.

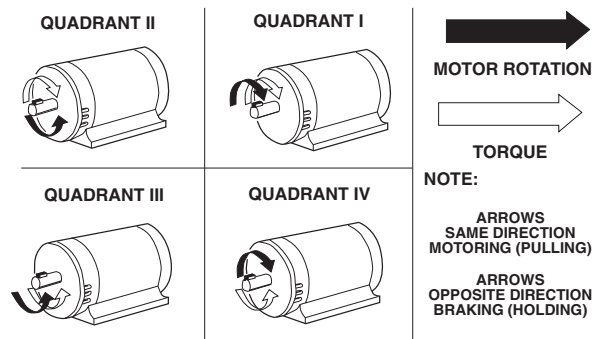

FIGURE 4.

TABLE 1. COMPARISON OF NONREGENERATIVE VS. REGENERATIVE DC DRIVE CAPABILITIES

	Nonregenerative	Regenerative
Braking	No inherent braking capability. Requires the addition of a dynamic braking circuit which dissipates the braking energy as heat in a resistor. Braking effort is exponential with initial high torque which reduces to zero at zero speed. Braking circuits are rated for stopping only, not continuous hold back, or as a holding brake.	Inherent electronically by regeneration whereby the kinetic energy of the motor and driven machine is restored to the AC power source. Can be regulated to control the braking torque down to, and at zero speed. Typically capable of continuous braking torque for hold back applications.
Reversing	No inherent reversing capability. Requires the addition of reversing contactors or a switch to reverse the polarity of DC voltage applied to the motor. Normally rated for occasional reversing.	An inherent capability. Motor polarity is reversed electronically with no contacts to arc, burn or wear. Desirable for applications requiring frequent reversals.
Simplicity	The least complex and least expensive form of electronic adjustable speed motor control.	More complex since it includes double the nonregenerative circuitry.
Efficiency and Speed Range	Controller efficiency up to 99%, complete drive with motor 87%. Speed range up to 50:1 without a feedback tachometer, 200:1 and greater with a tachometer.	

**Converter Types** – The power conversion or rectified power section of a DC drive is commonly called the converter. The individual characteristics of the various converter types used in standard industrial applications have had a definite influence in the design of compatible DC motors as shown in Table 2.

TABLE 2.								
Series	Rectified Power Source				Motor Ratings			
	Converter Type	NEMA Code	Form Factor	Ripple <sup>(2)</sup> Hz	Source VAC	HP Range	Armature VDC	Field VDC
P40 P60 DP60 DP60RG	Full Converter 6 SCR Nonregenerative 12 SCR Regenerative	C	1.01	360	230 460	5-125 5-1000	240 500	150 300
P25	Semiconverter 3 SCR, 4 Diode	D	1.05	180	230 460	5-10 5-20	240 500	150 300
Ratiopax BETA II DCX	Semiconverter 2 SCR, 3 Diode <sup>(1)</sup>	K	1.35	120	115,230	1-3	90, 180	50,100 100,200 100,200
BETAplus VEplus VED VERG	Full Converter 4 SCR Nonregenerative 8 SCR Regenerative <sup>(1)</sup>	–	–	120	115,230	1-5	90,180	100,200

NOTES: (1) Single-phase: others are three-phase  
 (2) Ripple frequency quoted for 60 Hz power source. 50 Hz power sources result in ripple currents 20%, higher than those for a 60 Hz source under the same operating conditions. The higher ripple produces additional heating which may be compensated by reducing the continuous load capability below base speed by approximately 5%. Form factor is at base speed, full load. Form factor of the current is the ratio of the rms current to the average current. For pure DC, such as a battery, the form factor is 1.0. For motors operated on rectified power the AC ripple content of the rectified current causes additional heating which increases as the square of the form factor. A motor is suitable for continuous operation of the form factor stamped on the data plate at rated load and rated speed. Actual motor heating when run from a half-wave converter should be determined by test, and is the responsibility of the purchaser.

### DC MOTOR CONTROL CHARACTERISTICS

A shunt-wound motor is a direct-current motor in which the field windings and the armature may be connected in parallel across a constant-voltage supply. In adjustable speed applications, the field is connected across a constant-voltage supply and the armature is connected across an independent adjustable-voltage supply. Permanent magnet motors have similar control characteristics but differ primarily by their integral permanent magnet field excitation.

The speed (N) of a DC motor is proportional to its armature voltage; the torque (T) is proportional to armature current, and the two quantities are independent, as illustrated in Figure 5.

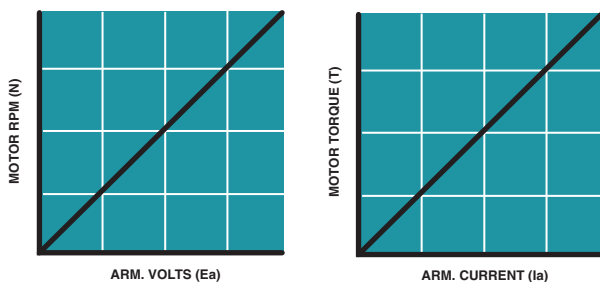

FIGURE 5. DC MOTOR CHARACTERISTICS

### CONSTANT TORQUE APPLICATIONS

Armature voltage controlled DC drives are constant torque drives. They are capable of providing rated torque at any speed between zero and the base (rated) speed of the motor as shown by Figure 6. Horsepower varies in direct proportion to speed, and 100% rated horsepower is developed only at 100% rated motor speed with rated torque.

### CONSTANT HORSEPOWER APPLICATIONS

**Armature Controlled DC Drives** – Certain applications require constant horsepower over a specified speed range. The screened area, under the horsepower curve in Figure 6, illustrates the limits of constant horsepower operation for armature controlled DC drives. As an example, the motor could provide constant horsepower between 50% speed and 100% speed, or a 2:1 range. However, the 50% speed point coincides with the 50% horsepower point. Any constant horsepower application may be easily calculated by multiplying the desired horsepower by the ratio of the speed range over which horsepower must remain constant. If 5 HP is required over a 2:1 range, an armature only controlled drive rated for 10 (5 x 2) horsepower would be required.

Table 3 provides a convenient listing of horsepower output at various operating speeds for constant torque drives.

**Field Controlled DC Drives** – Another characteristic of a shunt-wound DC motor is that a reduction in field voltage to less than the design rating will result in an increase in speed for a given armature voltage. It is important to note, however, that this results in a higher armature current for a given motor load. A simple method of accomplishing this is by inserting a resistor in series with the field voltage source. This may be useful for trimming to an ideal motor speed for the application. An optional, more sophisticated method uses a variable voltage field source as shown by Figure 6. This provides coordinated automatic armature and field voltage control for extended speed range and constant HP applications. The motor is armature voltage controlled for constant torque-variable HP operation to base speed where it is transferred to field control for constant HP-variable torque operation to motor maximum speed.

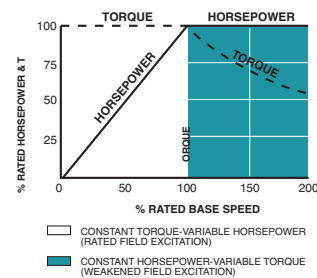

FIGURE 6.

### AC DRIVES – PRINCIPLES OF OPERATION

Adjustable frequency AC motor drive controllers frequently termed inverters are typically more complex than DC controllers since they must perform two power section functions, that of conversion of the AC line power source to DC and finally an inverter changes the DC to a coordinated adjustable frequency and voltage output to the AC motor. The appeal of the adjustable frequency drive is based upon the simplicity and reliability of the AC drive motor, which has no brushes, commutator or other parts that require routine

(Continued)

**TABLE 3. HORSEPOWER OUTPUT AT VARIOUS MOTOR SPEEDS WITH 1750 RPM BASE SPEED CONSTANT TORQUE DRIVES**

Rated HP At 1750 RPM Base Speed	Rated Torque At All Speeds Lb. -Ft. (1)	HP Ratings at Various Motor RPM										
		1575	1400	1225	1050	875	700	525	350	175	87.5	35
1/6	0.50	.150	.133	.117	.100	.083	.067	.050	.033	.017	.008	.003
1/4	0.75	.225	.200	.175	.150	.125	.100	.075	.050	.025	.013	.005
1/3	1.00	.300	.267	.233	.200	.167	.133	.100	.067	.033	.017	.007
1/2	1.50	.450	.400	.350	.300	.250	.200	.150	.100	.050	.025	.010
3/4	2.25	.675	.600	.525	.450	.375	.300	.225	.150	.075	.038	.015
1	3.00	.900	.800	.700	.600	.500	.400	.300	.200	.100	.050	.020
1-1/2	4.50	1.350	1.200	1.050	.900	.750	.600	.450	.300	.150	.075	.030
2	6.00	1.800	1.600	1.400	1.200	1.000	.800	.600	.400	.200	.100	.040
3	9.00	2.700	2.400	2.100	1.800	1.500	1.200	.900	.600	.300	.150	.060
5	15.00	4.500	4.000	3.500	3.000	2.500	2.000	1.500	1.000	.500	.250	.100
7-1/2	22.50	6.750	6.000	5.250	4.500	3.750	3.000	2.250	1.500	.750	.375	.150
10	30.00	9.000	8.000	7.000	6.000	5.000	4.000	3.000	2.000	1.000	.500	.200
15	45.00	13.500	12.000	10.500	9.000	7.500	6.000	4.500	3.000	1.500	.750	.300
20	60.00	18.000	16.000	14.000	12.000	10.000	8.000	6.000	4.000	2.000	1.000	.400
25	75.00	22.500	20.000	17.500	15.000	12.500	10.000	7.500	5.000	2.500	1.250	.500
30	90.00	27.000	24.000	21.000	18.000	15.000	12.000	9.000	6.000	3.000	1.500	.600
40	120.00	36.000	32.000	28.000	24.000	20.000	16.000	12.000	8.000	4.000	2.000	.800
50	150.00	45.000	40.000	35.000	30.000	25.000	20.000	15.000	10.000	5.000	2.500	1.000
60	180.00	54.000	48.000	42.000	36.000	30.000	24.000	18.000	12.000	6.000	3.000	1.200
75	225.00	67.500	60.000	52.500	45.000	37.000	30.000	22.500	15.000	7.500	3.750	1.500
100	300.00	90.000	80.000	70.000	60.000	50.000	40.000	30.000	20.000	10.000	5.000	2.00
125	375.00	112.500	100.000	87.500	75.000	62.500	50.000	37.500	25.000	12.500	6.250	2.50
Percent of Base Speed		90	80	70	60	50	40	30	20	10	5	2

Motors may require supplemental cooling when operated continuously at rated load at reduced speeds. See Motor Specifications.  
NOTE: (1) lb-in = lb - ft x 12

- (1) Torque ratings for other base speed motors:  
2500 RPM Motor = 1750 RPM Torque x .7 Approx.  
1150 RPM Motor = 1750 RPM Torque x 1.52 Approx.  
850 RPM Motor = 1750 RPM Torque x 2.06 Approx.

maintenance, which more than compensates for the complexity of the AC controller. The robust construction, and low cost of the AC motor makes it very desirable for a wide range of uses. Also, the ability to make an existing standard constant speed AC motor an adjustable speed device simply by the addition of an adjustable frequency controller creates a very strong incentive for this type of drive.

### AC CONTROLLER TYPES

A number of different types of AC motor controllers are currently in common use as general purpose drives: Six-Step or Variable Voltage Input (VVI), Pulse Width Modulated (PWM), Current Source Input (CSI), and the Load Commutated Inverter (LCI). Each type offers specific benefits and characteristics but the Six-Step and PWM types have been selected by Boston Gear as offering the best combination of simplicity, performance and economy for general purpose applications. Table 4 shows comparative advantages and disadvantages.

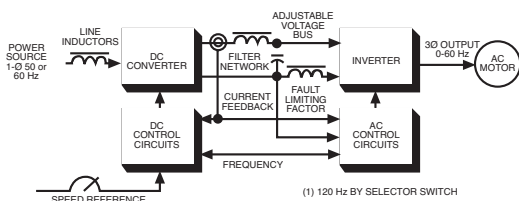

FIGURE 7.

**Six Step Controllers** – Six-Step controllers, so called due to their output voltage waveform, utilize an adjustable voltage, linkcoupled inverter system as shown in Figure 7.

The controller converts the AC power source to an adjustable DC voltage proportional to the speed reference command. The DC voltage is smoothed by a filter network and directed to a six-step inverter. The inverter changes the DC to AC at a frequency proportional to the speed reference. Output voltage and frequency are simultaneously coordinated and regulated to maintain a specific relationship of voltage and frequency (volts/Hz ratio) throughout the normal speed range. The voltage waveform applied to the motor is a stepped wave approximation of a true sinusoidal waveform as shown by Figure 8. The low harmonic content of this waveform has little adverse effect on the motor.

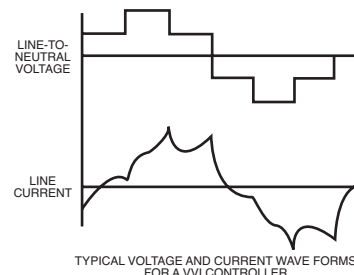

FIGURE 8.

**TABLE 4. COMPARISON OF PWM VERSUS SIX-STEP ADJUSTABLE FREQUENCY AC CONTROLLER CAPABILITIES**

Type	Advantages	Disadvantages
PWM	<ul style="list-style-type: none"> <li>Microprocessor based PWM units are typically less expensive than six-step units which commonly use SCR phase converters and analog techniques.</li> <li>30:1 and greater, constant torque speed range with smooth, noncogging low speed operation.</li> <li>High Power Factor—Displacement power factor is 96% or better over entire speed range at rated load.</li> <li>High Efficiency – Controller only 96%. Complete drive powered by a 3-phase source 83%, 70-80% when powered from a single-phase source, dependent upon motor efficiency.</li> <li>Power section with simple diode bridge AC to DC front end converter.</li> <li>Diode converter causes no line notching.</li> <li>Complex microprocessor circuitry easily serviced by substitution.</li> </ul>	<ul style="list-style-type: none"> <li>Audible motor noise may be objectionable for some applications. This can be minimized/eliminated with higher carrier frequencies, but this reduces controller efficiency (IGBT units allow higher switching frequencies, therefore less audible motor noise).</li> <li>Microprocessor control common to PWM inverters and high frequency power output tends to produce radiated, radio frequency interference (RFI) which may be objectionable in sensitive environments such as hospitals, communications centers, etc.</li> <li>Up to 2.5 times greater distortion of the AC voltage source than phase control input six step drives.</li> </ul>
Six-Step	<ul style="list-style-type: none"> <li>Quiet motor operation with minimal audible noise.</li> <li>Radiated RFI well within F.C.C. guidelines (non-microprocessor designs) making them desirable for sensitive applications such as hospitals.</li> <li>Minimal distortion of the AC voltage source with phase control input designs.</li> <li>Power factor 95% or less, variable with speed and load.</li> </ul>	<ul style="list-style-type: none"> <li>Speed range limited to 10:1 constant torque. Rated torque operation produces motor cogging at and below this speed.</li> <li>Phase controlled converter may produce notches in the AC line power source.</li> <li>Power factor reduces with speed and load.</li> <li>SCR phase converters and analog circuitry common to these units usually make them more expensive than PWM designs.</li> </ul>

**PWM Controllers**—The PWM controller converts the AC power source to a fixed DC voltage by a full-wave rectifier. The resultant DC voltage is smoothed by a filter network and applied to a pulse width modulated inverter using high power transistors. These transistors are normally Darlingtons, MOSFET (Metal Oxide Semiconductor Field Effect Transistor) or IGBT (Insulated Gate Bipolar Transistor) types. The MOSFET and IGBT types allow higher switching frequencies and therefore, less audible motor noise. The speed reference command is directed to the microprocessor which simultaneously optimizes the carrier (chopping) frequency and inverter output frequency to maintain a proper volts/Hz ratio and high efficiency throughout the normal speed range. See Block Diagram, Figure 9.

The voltage applied to the motor is a pulsed approximation of a true sinusoidal waveform as shown in Figure 10. This is

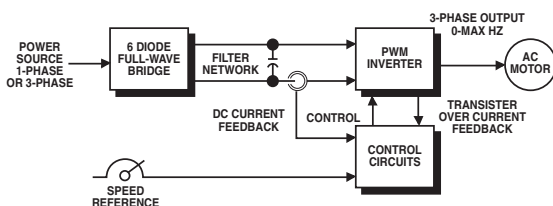

**FIGURE 9.**

commonly called a PWM waveform because both the carrier frequency and pulse-width is changed (modulated) to change the effective voltage amplitude and frequency. The current waveform very closely follows the shape of a sine wave and therefore provides improved low speed motor performance, efficiency, and minimizes motor heating.

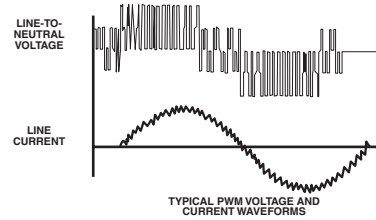

**FIGURE 10.**

### AC MOTOR CONTROL CHARACTERISTICS

The synchronous speed of an AC induction motor is directly proportional to the applied frequency.

$$\text{Speed} = \frac{120 \times \text{Frequency}}{\text{No. of Motor Poles}}$$

The synchronous speed is the speed of the rotating electrical field, not the actual motor rotor speed. The difference between the synchronous speed and the full-load motor speed is called slip, which is normally expressed in percent. The percentage of slip is determined by the design of the motor, primarily the rotor resistance. NEMA has assigned code letters (A, B, C, D, etc.) to standardize motor characteristics including slip. The type most commonly used is NEMA Design B with 3% slip at rated operating conditions. Figure 11 shows typical speed/torque curves for NEMA Design B and D motors.

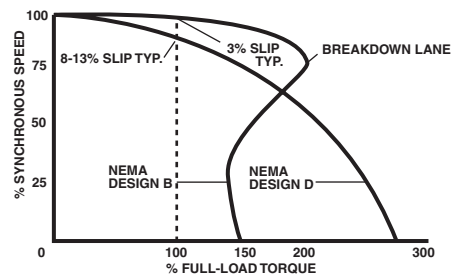

**FIGURE 11.**

As the applied frequency is changed, the motor will run faster or slower as shown by Figure 12. The actual full-load motor slip (as a percent of the motor synchronous speed) varies in inverse proportion to the frequency, where a 3% slip motor 60 Hz would have a 6% slip at 30 Hz or 1 1/2 % slip at 120 Hz. Motor speed is limited only by the maximum inverter output frequency, load torque requirements, and the mechanical integrity of the motor.

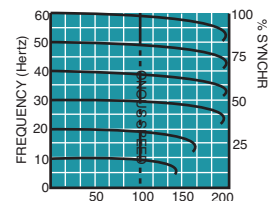
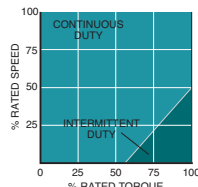

**FIGURE 12. TYPICAL SPEED TORQUE CURVES FOR 60 HZ NEMA DESIGN B MOTOR (WITHOUT VOLTAGE BOOST)**

### MOTOR SELECTION

**Constant Torque Applications**—About 90% of all general industrial machines, other than fans and pumps, are constant torque systems where the machine's torque requirement is independent of its speed. If the machine speed is doubled, its horsepower requirement doubles. Conversely a reduction in machine speed by 50% will result in an equal reduction in horsepower, but no reduction in torque.

- Standard three-phase AC motors, designed for fixed speed operation at standard line frequency, may be easily adapted for use with the AC controller by considering the following:
  - A slight increase in motor losses occurs with inverter power.
  - The motor thermal capacity must typically be derated as a function of the minimum, continuous operating speed in accord with Figure 13, due to the reduced ventilation provided by the integral motor fan. Where the application requires 100% rated torque at speeds below 50% of synchronous speed, a separately powered ventilation blower, a nonventilated motor with greater reserve thermal capacity or, a motor with higher rated capacity should be used. When a separately powered ventilation blower is used, a thermostat should be built into the motor to prevent damage which may result from a failure in the ventilation system.
- Any three-phase synchronous or induction AC motor designed expressly for adjustable speed service by inverter control may normally be used over its design speed range with the AC controller.



**FIGURE 13. TYPICAL STANDARD AC MOTORS ADJUSTABLE SPEED OPERATION**

**Variable Torque Applications**—The application of standard AC motors to adjustable speed variable torque applications such as centrifugal fans or pumps is ideal from a motor cooling standpoint. The torque characteristics of a variable torque (cubed exponential horsepower) load are such that the load falls off rapidly as the motor speed is reduced. The variable torque load eliminates the necessity to derate the motor due to excessive heat resulting from diminished motor cooling at reduced speeds. Figure 14 illustrates the relationship between speed and torque in variable torque applications.

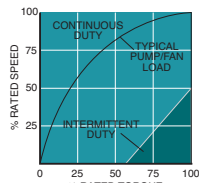

**FIGURE 14. TYPICAL STANDARD AC MOTOR APPLICATION WITH VARIABLE TORQUE LOADS**

**Potential Power Savings**—Most fan and pump applications require the system to run for sustained periods at reduced outputs by either reducing the speed of the motor or by mechanically altering the flow. Figure 15 illustrates typical energy savings, in percent of rated power, which can be realized when using an adjustable frequency

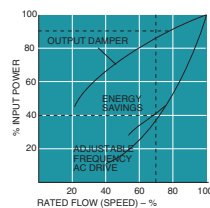

**FIGURE 15. ENERGY SAVINGS**

controller to reduce motor speed and thereby system flow as opposed to a constant speed motor which has its system flow varied by an outlet damper.

**Constant Torque Operation**—The ability of the AC controller to maintain a constant volts/Hz relationship is ideal from a motor standpoint. This permits operation of the motor at rated torque from near standstill to rated speed.

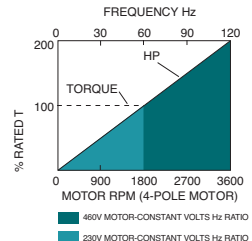
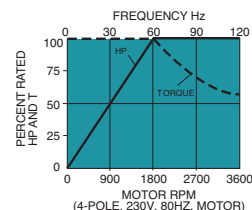

**FIGURE 16. CONSTANT TORQUE OPERATION**

Figure 16 represents the relationship between torque, horsepower and motor speed with a maintained volts/Hz ratio using a 60 Hz controller for illustration. A standard 4-pole 460V motor can be controlled by this method to its synchronous speed of 1800 RPM. If the same motor were wound for 50% of the input voltage (230V), it could be controlled with constant torque to double the normal rated speed and horsepower. The motor would not be “overvoltaged” because the volts/Hz ratio could be maintained e.g.: a motor wound for 230 VAC can supply constant torque to twice the AC line frequency when used on a 460V power source without overvoluting the motor because the volts/Hz ratio of 230V/60 Hz is the same as 460V/120 Hz. The horsepower would also double since the same torque would be developed at twice the normal rated speed.

Caution must be observed when applying standard motors for continuous low speed, rated torque operation. The motor's self-cooling capability is dependent upon self-ventilation schemes with efficiency that is considerably reduced at lower operating speeds.

**Constant Horsepower Operation**—AC motor controllers are also adaptable to constant horsepower operation as shown by Figure 17. With this mode of operation, the volts/Hz ratio is maintained to a specific frequency, normally 50 or 60 Hz. At this point, the voltage is “clamped” at a constant level while the frequency is adjusted further to achieve the desired maximum speed. Since the controller maximum output voltage is limited to the voltage of the AC power source, the volts/Hz ratio must decrease beyond this point as the frequency increases. The motor becomes “voltage starved” above the clamping point and torque decreases as speed increases, resulting in constant horsepower output.



**FIGURE 17. TYPICAL CONSTANT HP OPERATION**

As shown in Figure 17 the drive provides conventional constant torque/variable horsepower operation up to 60 Hz which is equivalent to the 1800 RPM base speed of the 60 Hz motor. Between 1800 and 3600 RPM, the drive provides constant horsepower/variable torque operation. If constant horsepower is required between 900 and 3600 RPM (a 4:1 speed range) — using the same 1800 RPM base speed motor, the drive rated horsepower must be increased since 900 RPM intersects the curve at a point which is 50% of rated horsepower.

Constant HP operation (above synchronous speed) is limited to induction motors only. In addition, at some point, typically around three times base speed for a four-pole induction motor, the breakdown torque of the motor prevents further constant horsepower operation. Synchronous reluctance motor characteristics prevent operation in this mode.

### Multiple Motor Operation (From a Common Controller) –

An adjustable frequency AC motor controller is ideally suited for simultaneous control of multiple motors in process line applications. All motors are operated at a common frequency and are therefore synchronized at a common speed. Tracking accuracy between the individual motors varies only the difference in their loads, typically 0.5% to 3% with standard NEMA Design B motors and 0.0% with synchronous reluctance types.

Where tracking ratios other than 1:1 are desirable, gear boxes, fixed or adjustable sheaves may be used to attain the desired individual speeds. Two-pole, four-pole and six-pole motors may also be mixed to obtain various individual motor operating speeds when operated from a common adjustable frequency controller. Selection of a properly rated controller should be made with consideration for the total KVA required by all the motors which are normally started and stopped simultaneously. Some process line applications require the ability to selectively start and stop one or more of the motors while the others are operated at the desired speed. A standard motor started under this condition instantaneously draws locked-rotor current of 600-800%. Unless this factor is considered in the selection of an adequately rated controller, the additional load may exceed the capacity of the power unit, reducing the voltage to the entire system which could cause the line to stall or trip off.

### AC VS. DC DRIVE COMPARISON

AC and DC drives both continue to offer unique benefits and features that may make one type or other better suited for certain applications.

#### AC drives may be better because . . .

- They use conventional, low cost, 3-phase AC induction motors for most applications.
- AC motors require virtually no maintenance and are preferred for applications where the motor is mounted in an area not easily reached for servicing or replacement.
- AC motors are smaller, lighter, more commonly available, and less expensive than DC motors.
- AC motors are better suited for high speed operation (over 2500 rpm) since there are no brushes, and commutation is not a problem.
- Whenever the operating environment is wet, corrosive or explosive and special motor enclosures are required. Special AC motor enclosure types are more readily available at lower prices.
- When multiple motors in a system must operate simultaneously at a common frequency/speed.
- When it is desirable to use an existing constant speed AC motor already mounted and wired on a machine.
- When the application load varies greatly and light loads may be encountered for prolonged periods. DC motor commutators and brushes may wear rapidly under this condition.
- When low cost electronic motor reversing is required.
- Whenever it is important to have a back up (constant speed) if the controller should fail.

#### DC drives may be better because . . .

- DC drives are less complex with a single power conversion from AC to DC.
- DC drives are normally less expensive for most horsepower ratings.
- DC motors have a long tradition of use as adjustable speed machines and a wide range of options have evolved for this purpose:
- Cooling blowers and inlet air flanges provide cooling air for a wide speed range at constant torque.
- Accessory mounting flanges and kits for mounting feedback tachometers and encoders.
- DC regenerative drives are available for applications requiring continuous regeneration for overhauling loads. AC drives with this capability would be more complex and expensive.
- When properly applied brush and commutator maintenance is minimal.
- DC motors are capable of providing starting and accelerating torques in excess of 400% of rated.
- Some AC drives may produce audible motor noise which is undesirable in some applications.
- DC SCR drives have been the first choice of industry for over 25 years. Their maintenance, technology, serviceability and reliability are well understood by plant maintenance personnel.

### BASIC MECHANICS

The curve in Figure 6 shows a distinct relationship between speed, torque and horsepower. Torque is constant at any speed while there is a direct proportional relationship between horsepower and speed; horsepower varies directly with the speed. Therefore, horsepower is motion dependent, torque is not.

#### TORQUE

A force applied in a manner that tends to produce rotation, such as a pipe wrench on a shaft. Torque (force) without rotation is termed static torque, since no motion is produced.

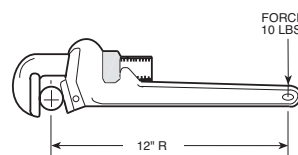

FIGURE 18

Torque is measured in lb-in or lb-ft which is the product of the force in pounds (lb) x the distance in inches (in) or feet (ft) from the center of the point of apparent rotation. Figure 18 shows 120 lb-in (12 inches x 10 lbs) or 10 lb-ft torque.

Because most power transmission is based upon rotating elements, torque is important as a measurement of the effort required to produce work (horsepower).

#### POWER (Horsepower)

A force applied in a manner that produces motion and, therefore, work over a specified time period. A common unit of power is horsepower. **One horsepower (HP) is defined as the force required to lift 33,000 lbs, one foot in one minute.**

### THREE BASIC FACTORS ARE INVOLVED:

Factor	Unit
Distance (Radius)	Foot (or inches)
Force (Push or Pull)	Pounds
Time	One (1) Minute
$HP = \frac{F \text{ (Load in Pounds)} \times \text{Feet per Minute}}{33,000}$	

### HORSEPOWER-TORQUE, GETTING IT TOGETHER

As shown in Figure 19, the 50 lb load is acting on the 5 inch radius (distance) of the winch, producing a load torque of 250 lb-in (50 lbs x 5 inches) that must be overcome to lift the load. Since the hand crank arm has a 10 inch radius (distance), a minimum force of 25 lbs must be exerted to overcome the load torque (25 lbs x 10" = 250 lb-in). If no motion is involved, the system is in balance. Although torque is being exerted, no work is accomplished and no horsepower is developed.

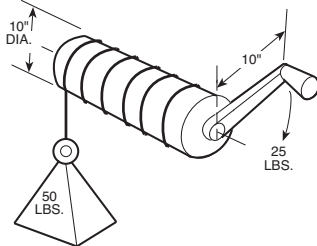

FIGURE 19

The winch diameter is 10 inches. Therefore, each revolution of the hand crank will lift the weight 10 inches x  $\pi$  = 31.418 inches (2.618 feet).

If the crank is turned at 10 RPM, 50 lbs will be lifted a distance of 26.18 feet in one minute:

$$HP = \frac{(\text{Load in Pounds}) \times \text{Feet per Minute}}{33,000}$$

$$HP = \frac{50 \times 26.18}{33,000} = .03966 \text{ HP}$$

Turning the crank twice as fast (20 RPM) will develop twice the horsepower.

$$HP = \frac{50 \times 52.36}{33,000} = .07933 \text{ HP}$$

Thus, the horsepower of rotating elements can be calculated from the following formula:

$$HP = \frac{F \times 2\pi \times R \times \text{RPM}}{33,000} = \frac{T \times \text{RPM}}{5252}$$

Where,

F = force in pounds  
 R = radius (lever length in feet)  
 RPM or N = revolutions per minute  
 T = torque in lb-ft (F x R)

### SELECTING A DRIVE FOR A MACHINE

The application of an adjustable speed drive to power a machine is a mechanical, rather than an electrical problem. When applying the drive, the speed – torque – horsepower characteristics developed at the drive motor shaft must be considered, and how well these characteristics suit the machine.

Four essential parameters are

1. Breakaway Torque
2. Process Torque
3. Accelerating Torque
4. Running Torque

### BREAKAWAY TORQUE –

The torque required to start the machine in motion.

It is most always greater than the torque required to maintain motion (running torque). Breakaway torque combined with process torque frequently determines drive selection. Table 5 lists typical breakaway torques for various machine types.

TABLE 5. TYPICAL BREAKAWAY TORQUES FOR VARIOUS MACHINE TYPES

Machine Types	Breakaway Torque*	Drive Selection
Machines with ball or roller bearings	110 to 125%	Standard drive rating
Machines with sleeve bearings	130 to 150%	Standard drive rating
Conveyors and machines with excessive sliding friction	160 to 250%	Oversize drive
Machines that have "high" load spots in their cycle, e.g., printing and punch presses, and machines with cam or crank operated mechanisms	250% to 600%	Oversize drive
High Inertia – Machines with fly-wheels or other heavy rotating masses. Also, some machines that move large masses by cranks, centrifuges, etc.	Nominal rating of drive will depend on the breakaway torque requirement	Drive rating dependent upon desired acceleration time and drive torque

\*Typical percentages of running torque

### PROCESS TORQUE –

The torque required to pull, push, compress, stretch or otherwise process or act upon the material being transported by or through the machine.

On some machines, process torque may be so significant as to determine the drive power rating. On other machines, this load may be insignificant. The process torque load is superimposed on all other static and dynamic torque requirements of the machine.



### ACCELERATING TORQUE –

The torque required to bring the machine to an operating speed within a given time.

With most machines, the load is largely friction and a standard drive rating may have adequate torque for satisfactory acceleration. However, certain machines classified as "high inertia" with flywheels, bull gears or other large rotating masses may require drive selection based upon the power required to accelerate the load within a given time.

### RUNNING TORQUE –

The torque required to maintain machine motion after it accelerates to the desired operating speed.

The characteristics of the speed-torque curves of various machines are very important to proper adjustable speed drive selection. Most machines fall into four basic categories:

1. Constant Torque (Figure 20)
2. Constant Horsepower (Figure 21)
3. Squared Exponential Horsepower (Figure 22)
4. Cubed Exponential Horsepower (Figure 23)

Some machines may have operating characteristics which are a composite of the basic types.

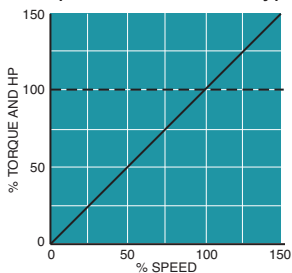

Figure 20. Constant Torque Horsepower

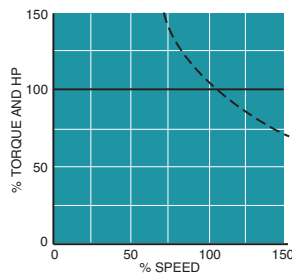

Figure 21. Constant

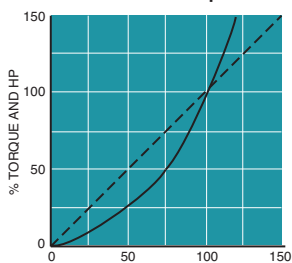

Figure 22. Squared Exponential Horsepower

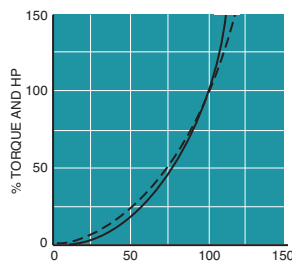

Figure 23. Cubed Exponential Horsepower

----- Torque    \_\_\_\_\_ HP

### CONSTANT TORQUE –

Most industrial machine applications, other than pumps, are constant torque systems.

The machine's torque requirement is independent of its speed. If the machine speed is doubled, its horsepower requirement doubles. This fact must be kept in mind when replacing a constant speed drive with an adjustable speed drive and the machine operating speed is increased.

### CONSTANT HORSEPOWER –

For machines with constant horsepower loads, the power demand is independent of speed, and torque varies inversely with speed.

This type is most often found in the machine-tool industry and with center driven winders. When drilling, shaping, milling, or turning metal, the loads all tend toward constant horsepower. At low speed there is high torque; at high speed, light torque. A drive must be selected for its highest torque condition which is at the lowest speed of the range. With most machines, the "constant horsepower range" seldom exceeds a 3:1 range.

### SQUARED-EXPONENTIAL LOADS –

With machines of this type, torque varies directly as the speed, and power as the square of speed.

Such relationships are frequently found in positive-displacement pumps and mixer applications.

### CUBED-EXPONENTIAL LOADS –

It is characteristic of these machines that torque varies as the square of speed, and power as the cube of speed.

This type of load is imposed on centrifugal pump drives and most fan or blower drives. In some uses, fan or blower horsepower varies as the fifth power of speed. The exponential relationship is characteristic of these machines. This fact must be considered when sizing motors for adjustable speed drives. If the speed of a centrifugal pump is doubled, its power requirement increases by a factor of eight.

### OTHER APPLICATION FACTORS

#### CONSTANT TORQUE SPEED RANGE –

On large motors, minimum operating speed limitations may be necessary for self-ventilated motors, since their cooling is entirely dependent upon motor speed and, therefore, diminishes as speed is reduced. Where rated torque operation is required continuously at lower speeds, either a higher rated drive motor or supplemental motor ventilation, such as a motor mounted cooling blower or external air duct, is required.

#### TORQUE LIMITATIONS –

Most adjustable speed drives feature a torque limiter to protect the drive and the machine from torque overloads. The torque limiter (current limit) is normally adjusted to 150% of rated torque to allow extra momentary torque for breakaway, acceleration or cyclic overloads. Most drive systems are capable of sustaining the 150% torque overload for one minute or less.

#### DUTY CYCLE –

Certain applications may require continuous reversals, long acceleration times at high torque due to inertia loads, frequent high rate acceleration, or cyclic overloads which may result in severe motor heating if not considered in the selection of the drive. Most drives with 150% overload capability will operate successfully if there are compensating periods of operation where motor temperatures can be normalized.

#### MEASURING MACHINE TORQUE

To measure the torque required to drive a machine, fasten a pulley securely to the shaft which the motor is to drive. Fasten one end of a cord to the outer surface of the pulley and wrap a few turns of the cord around the pulley. Tie the other end of the cord to a spring scale. See Figure 24.

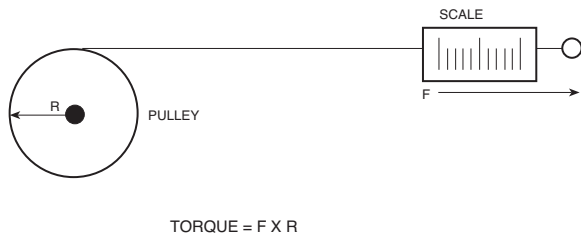

**Figure 24.**

Pull on scale until the shaft turns. The force in pounds or ounces, indicated on the scale, multiplied by the radius of the pulley (measured from the centerline of the machine shaft) in inches gives the torque value in lb-inches or oz-inches. On some machines, this torque may vary as the shaft rotates. The highest value of torque must be used when selecting a motor.

The running torque required by a machine will be approximately equal to the starting torque if the load is composed almost entirely of friction. If the load is primarily inertia or windage, the characteristics of the inertia or windage producing elements must be determined.

The running torque of a machine can be accurately determined by making a test run with an armature controlled DC drive (with a shunt wound or permanent magnet DC motor) of known horsepower rating. The DC drive should have an ammeter in the armature circuit so significant current readings can be observed and recorded throughout the speed range of the machine. Since armature current and torque are directly proportional within very close limits, the current readings will provide accurate information for selecting the drive rating required by the machine.

Most machines require a higher torque value for breakaway, but once running, the torque requirement will decrease. Many drives have 150% load capability for one minute, which may allow the required additional breakaway torque to be obtained without increasing the drive horsepower rating.

If the running torque is equal to or less than the breakaway torque divided by 1.5, use the breakaway torque divided by 1.5 as the full-load torque required to determine the motor horsepower.

If the running torque is greater than the breakaway torque divided by 1.5, but less than the breakaway torque, use the running torque as the full load rated torque required to determine the motor horsepower.

### MECHANICAL FORMULAS

#### HOW TO CALCULATE TORQUE

If the horsepower and base speed of a motor are known, the full-load torque of the motor is determined by:

$$T = \frac{(5250) (HP)}{N}$$

Where, T = Torque (lb-ft)  
 HP = Horsepower  
 N = Base speed of motor (RPM)

#### HOW TO CALCULATE HORSEPOWER

For Rotating Objects:

$$HP = \frac{TN}{63,025} \quad \text{Where, } T = \text{Torque (lb-in)} \\ N = \text{Speed (RPM)}$$

or:

$$HP = \frac{TN}{5250} \quad \text{Where, } T = \text{Torque (lb-ft)} \\ N = \text{Speed (RPM)}$$

For Objects in Linear Motion:

$$HP = \frac{FV}{396,000} \quad \text{Where, } F = \text{Force (lb)} \\ V = \text{Velocity (IPM)}$$

or:

$$HP = \frac{FV}{33,000} \quad \text{Where, } F = \text{Force (lb)} \\ V = \text{Velocity (FPM)}$$

For Pumps:

$$HP = \frac{(\text{GPM}) \times (\text{Head in Feet}) \times (\text{Specific Gravity})}{3950 \times (\text{Efficiency of Pump})}$$

For Fans and Blowers:

$$HP = \frac{\text{CFM} \times (\text{Pressure in Pounds/Sq ft})}{33,000 \times \text{Efficiency}}$$

When calculated horsepower falls between standard motor ratings, select the next higher rating.

#### CALCULATING ACCELERATING FORCE FOR LINEAR MOTION.

The following formula can be used to calculate the approximate accelerating force required for linear motion. However, before sizing the drive, add the torque required to accelerate the motor armature, gears, pulleys, etc. to the linear-motion accelerating force converting to torque.

$$\text{Acceleration Force (F)} = \frac{W (\Delta V)}{1933t}$$

Where, W = Weight (lb)  
 $\Delta V$  = Change in velocity (FPM)  
 t = Time (seconds) to accelerate weight

#### CALCULATING ACCELERATING TORQUE FOR ROTARY MOTION

When, in addition to the selection of a motor with proper torque capacity to start and maintain machine motion, a desired time for acceleration is involved and the required torque value may be affected, an additional formula must be considered. This formula makes it possible to calculate the average torque required over the complete range of speed change to accelerate a known inertia ( $WK^2$ ).

On high inertia loads, accelerating torque may be the major factor in the drive selection.

The formula to calculate acceleration torque (torque required above load torque) or a rotating member:

$$T = \frac{(WK^2) (\Delta N)}{308t}$$

Where,  $T$  = Acceleration torque (lb-ft)  
 $WK^2$  = Total system inertia (lb-ft<sup>2</sup>) that the motor must accelerate. This value includes motor armature, reducer and load.  
 $\Delta N$  = Change in speed required (RPM)  
 $t$  = Time to accelerate total system load (seconds)

The same formula can also be used to determine the minimum acceleration time of a given drive, or if it can accomplish the desired change in speed within the required time period.

$$t = \frac{(WK^2) (\Delta N)}{308T}$$

### INERTIA (WK<sup>2</sup>)

The factor  $WK^2$  is the weight (lbs) of an object multiplied by the square of the radius of gyration (K). The unit measurement of the radius of gyration is expressed in feet.

For solid or hollow cylinders, inertia may be calculated by the equations shown in Figure 25.

$$WK^2 = \text{lb-ft}^2$$

$D, D_1, D_2$  and  $L$  = in.

$$\rho = \text{lb./in.}^3$$

$$\rho \text{ (aluminum)} = .0924$$

$$\rho \text{ (bronze)} = .320$$

$$\rho \text{ (cast iron)} = .260$$

$$\rho \text{ (steel)} = .282$$

The inertia of solid steel shafting per inch of shaft length is given in Table 6. To calculate for hollow shafts, take the difference between the inertia values for the O.D. and I.D. as the value per inch. For shafts of materials other than steel, multiply the value for steel by the factors in Table 7.

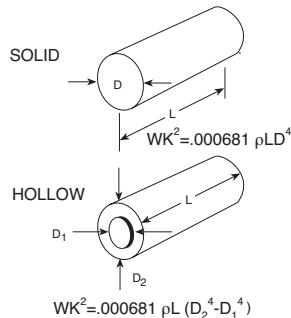

FIGURE 25.

Diam. (IN.)	WK <sup>2</sup> (lb Ft <sup>2</sup> )	Diam. (IN.)	WK <sup>2</sup> (lb Ft <sup>2</sup> )
3/4	0.00006	10-1/2	2.35
1	0.0002	10-3/4	2.58
1-1/4	0.0005	11	2.83
1-1/2	0.001	11-1/4	3.09
1-3/4	0.002	11-1/2	3.38
2	0.003	11-3/4	3.68
2-1/4	0.005	12	4.00
2-1/2	0.008	12-1/4	4.35
2-3/4	0.011	12-1/2	4.72
3	0.016	12-3/4	5.11
3-1/2	0.029	13	5.58
3-3/4	0.038	13-1/4	5.96
4	0.049	13-1/2	6.42
4-1/4	0.063	13-3/4	6.91
4-1/2	0.079	14	7.42
5	0.120	14-1/4	7.97
5-1/2	0.177	14-1/2	8.54
6	0.250	14-3/4	9.15
6-1/4	0.296	15	9.75
6-1/2	0.345	16	12.59
6-3/4	0.402	17	16.04
7	0.464	18	20.16
7-1/4	0.535	19	25.03
7-1/2	0.611	20	30.72
7-3/4	0.699	21	37.35
8	0.791	22	44.99
8-1/4	0.895	23	53.74
8-1/2	1.00	24	63.71
8-3/4	1.13	25	75.02
9	1.27	26	87.76
9-1/4	1.41	27	102.06
9-1/2	1.55	28	118.04
9-3/4	1.75	29	135.83
10	1.93	30	155.55
10-1/4	2.13	—	—

SHAFT MATERIAL	FACTOR
Rubber	.121
Nylon	.181
Aluminum	.348
Bronze	1.135
Cast Iron	.922

### FORMULAS TO APPROXIMATE WK<sup>2</sup>

For a solid cylinder or disc =  $W \times \frac{r^2}{2}$

where  $r$  = radius in feet and  $W$  is weight in pounds.

For a hollow cylinder:  $W K^2 = W \times \frac{r_1^2 + r_2^2}{2}$

where  $r_1$  is  $\frac{ID}{2}$  and  $r_2$  is  $\frac{OD}{2}$ .

The inertia of complex concentric rotating parts is calculated by breaking the part up into simple rotating cylinders, calculating their inertia and summing their values, as shown in Figure 26.

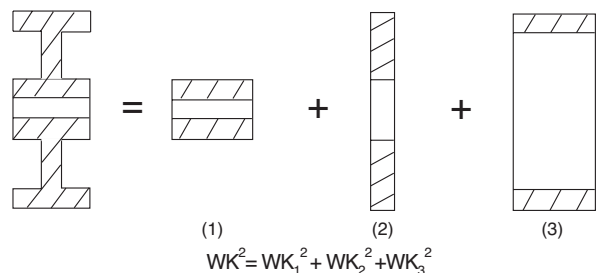

FIGURE 26.

# APPLICATION ENGINEERING

## AC & DC Controllers

### WK<sup>2</sup> OF ROTATING ELEMENTS

In practical mechanical systems, all the rotating parts do not operate at the same speed. The WK<sup>2</sup> of all moving parts operating at each speed must be reduced to an equivalent WK<sup>2</sup> at the motor shaft, so that they can all be added together and treated as a unit, as follows:

$$\text{Equivalent WK}^2 = \text{WK}^2 \left[ \frac{N}{N_M} \right]^2$$

Where, WK<sup>2</sup>=Inertia of the moving part  
 N = Speed of the moving part (RPM)  
 N<sub>M</sub>=Speed of the driving motor (RPM)

When using speed reducers, and the machine inertia is reflected back to the motor shaft, the equivalent inertia is equal to the machine inertia divided by the square of the drive reduction ratio.

$$\text{Equivalent WK}^2 = \frac{\text{WK}^2}{(\text{DR})^2}$$

Where, DR = drive reduction ratio =  $\frac{N_M}{N}$

### WK<sup>2</sup> OF LINEAR MOTION

Not all driven systems involve rotating motion. The equivalent WK<sup>2</sup> of linearly moving parts can also be reduced to the motor shaft speed as follows:

$$\text{Equivalent WK}^2 = \frac{W(V)^2}{39.5(N_M)^2}$$

Where, W = Weight of load (lbs)  
 V = Linear velocity of rack and load or conveyor and load (FPM)  
 N<sub>M</sub>=Speed of the driving motor (RPM)

**NOTE:** This equation can only be used where the linear speed bears a continuous fixed relationship to the motor speed, such as a conveyor.

### ELECTRICAL FORMULAS

#### OHMS Law:

$$\text{Amperes} = \frac{\text{Volts}}{\text{Ohms}}$$

$$\text{Ohms} = \frac{\text{Volts}}{\text{Amperes}}$$

$$\text{Volts} = \text{Amperes} \times \text{Ohms}$$

### POWER IN DC CIRCUITS:

$$\text{Watts} = \text{Volts} \times \text{Amperes}$$

$$\text{Horsepower} = \frac{\text{Volts} \times \text{Amperes}}{746}$$

$$\text{Kilowatts} = \frac{\text{Volts} \times \text{Amperes}}{1000}$$

$$\text{Kilowatt-Hours} = \frac{\text{Volts} \times \text{Amperes} \times \text{Hours}}{1000}$$

### POWER IN AC CIRCUITS:

Kilovolt - Amperes (KVA)

$$\text{KVA (Single-Phase)} = \frac{\text{Volts} \times \text{Amperes}}{1000}$$

$$\text{KVA (Three-Phase)} = \frac{\text{Volts} \times \text{Amperes} \times 1.73}{1000}$$

Kilowatt (Kw)

$$\text{Kw (Single-Phase)} = \frac{\text{Volts} \times \text{Amperes} \times \text{Power Factor}}{1000}$$

$$\text{Kw (Two-Phase)} = \frac{\text{Volts} \times \text{Amperes} \times \text{Power Factor} \times 1.42}{1000}$$

$$\text{Kw (Three-Phase)} = \frac{\text{Volts} \times \text{Amperes} \times \text{Power Factor} \times 1.73}{1000}$$

$$\text{Power Factor} = \frac{\text{Kilowatts}}{\text{Kilovolts} \times \text{Amperes}}$$

### CONVERSION FACTORS

	MULTIPLY	BY	TO OBTAIN
Length	Meters	3.281	Feet
	Meters	39.37	Inches
	Inches	.0254	Meters
	Feet	.3048	Meters
	Millimeters	.0394	Inches
Torque	Newton-Meters	.7376	Lb-Ft
	Lb-Ft	1.3558	Newton-Meter
	Lb-In	.0833	Lb-Ft
	Lb-Ft	12.00	Lb-In
Rotation	RPM	6.00	Degrees/Sec.
	RPM	.1047	Rad./Sec.
	Degrees/Sec.	.1667	RPM
	Rad./Sec.	9.549	RPM
Moment of Inertia	Newton-Meters <sup>2</sup>	2.42	Lb-Ft <sup>2</sup>
	Oz-In <sup>2</sup>	.000434	Lb-Ft <sup>2</sup>
	Lb-In <sup>2</sup>	.00694	Lb-Ft <sup>2</sup>
	Slug-Ft <sup>2</sup>	32.17	Lb-Ft <sup>2</sup>
	Oz-In-Sec <sup>2</sup>	.1675	Lb-Ft <sup>2</sup>
	Lb-In-Sec <sup>2</sup>	2.68	Lb-Ft <sup>2</sup>
Power	Watts	.00134	HP
	Lb-Ft/Min	.0000303	HP
Temperature		Degree C = (Degree F -32) × 5/9	
		Degree F = (Degree C × 9/5) + 32	

### CURRENT RATINGS OF INSULATED COPPER CONDUCTORS

**TABLE 8. ALLOWABLE CURRENT CARRYING CAPACITIES**  
(Amperes) of Insulated Copper Conductors. Not more than three conductors in raceway or direct burial, based on 30°C (86°F) ambient (Condensed from National Electrical Code)

Type of Insulation	Maximum Operating Temperature	Wire Size AWG or MCM												*Correction Factors	
		14	12	10	8	6	4	3	2	1	0	00	000	31–40°C	41–50°C
		Allowable Line Amperes													
T-TW	60°C	15	20	30	40	55	70	80	95	110	125	145	165	.82	.58
RH,RHW, THW,THWN, XHHW	75°C	15	20	30	45	65	85	100	115	130	150	175	200	.88	.75
V-C(V) V-C(AVB) THHN,RHH, XHHW	85-90°C	25	30	40	50	70	90	105	120	140	155	185	210	.90	.80

Type of Insulation	Maximum Operating Temperature	Wire Size AWG or MCM												*Correction Factors	
		0000	250	300	350	400	500	600	700	750	800	900	1000	31–40°C	41–50°C
		Allowable Line Amperes													
T-TW	60°C	195	215	240	260	280	320	355	385	400	410	435	455	.82	.58
RH,RHW, THW,THWN, XHHW	75°C	230	255	285	310	335	380	420	460	475	490	520	545	.88	.75
V-C(V) V-C(AVB) THHN,RHH, XHHW	85-90°C	235	270	300	325	360	405	455	490	500	515	555	585	.90	.80

\*For room temperatures above 30°C.

### DEFINITIONS

Performance specifications listed for the basic Boston Gear adjustable-speed drives in the standard specification sheets and those provided with companion functional options are based upon the following conditions:

### DRIVE SPEED REGULATION

The motor speed change between minimum load and full-load torque, expressed as a percentage of the full-load motor speed. This change is measured after all transient disturbances, due to load change, have terminated.

(1)

$$\% \text{ Regulation} = \frac{(\text{Min-Load Speed}) - (\text{Full-Load Speed})}{\text{Motor Rated Speed}} \times 100$$

Minimum-load is normally expressed as 5% of rated full load.

For drives with armature controlled DC motors, the rated speed is the motor operating speed when developing full-load torque with 100% rated armature voltage and field power applied. This is normally termed base speed.

For drives operated in the field weakened range, regulation is specified as a percentage of top speed.

Speed regulation for standard drives is expressed as a percentage of base speed. Set speed regulation is expressed as a percentage change in speed from an operating point (set speed) due to load changes. If a drive had 1% regulation of base speed, a 2% change of set speed could result at 1/2 motor speed.

Formula (1) is more realistic than Formula (2), since the friction in the driven machine normally loads the motor appreciably, and the changing work load on the machine subjects the motor to a smaller speed change than from absolute no-load to full-load torque.

(2)

$$\% \text{ Regulation} = \frac{(\text{No-Load Speed}) - (\text{Full-Load Speed})}{\text{Motor Rated Speed}} \times 100$$

### DRIVE SPEED RANGE

Any motor speed between minimum and maximum that can be obtained in a stable manner. For most static, electronic drives it is normally specified that the minimum speed is zero and the maximum speed is the motor base speed.

“Controlled Speed Range” specifies the operating range with respect to the quoted drive speed regulation. This is typically expressed as a ratio of the minimum to maximum speeds such as 20:1, 50:1, etc. Typically, high performance drives will offer close speed regulation along with wide speed range capability.

### DRIVE SERVICE FACTOR

A multiplier, which when applied to the drive rated horsepower, indicates a permissible maximum loading at which the drive can be operated continuously. To determine the horsepower required for greater than standard service factor, multiply the rated horsepower by the service factor. If the rating thus calculated is not standard, select a drive (same base speed motor) with the next higher rating. Boston Gear's standard drives have a 1.0 service factor.

### STEADY-STATE REGULATION

The regulated value due to the following variation in operating parameters occurring independently or simultaneously. (Load remaining constant for speed and voltage regulators.)

VARIABLE	VARIATION	RANGE
AC Supply Voltage	10% with rate of change not to exceed 2.5% per second	±10% of nominal voltage
AC Supply Frequency	2 Hz variation with rate of change not to exceed 2.5% per second	58-62 Hz (60 nominal) 48.5-51.5 Hz (50 nominal)
Ambient Temperature Random Drift	15°C 8 hour period after 1 hour warmup	0 to 40°C

### TEMPERATURE

A change in ambient temperature produces a change in the control variable expressed as a percentage change for a specified temperature change of ±10°C. All standard units are designed to operate with a maximum enclosure interior temperature of 55°C surrounding the regulator power conversion module.

### TRANSIENT DEVIATION

A momentary speed change from a speed set point, occurring at the result of a specified rate of load change. Performance is dependent on load inertia, motor inertia, load friction, etc.

### TRANSIENT RESPONSE TIME

Time required to recover and maintain speed within the specified regulation tolerance after a specified change in load. Performance is dependent on load inertia, motor inertia, load friction, etc.

### RANDOM DRIFT

A change from initial set speed during an unchanging load condition over specified time period with constant reference input, constant temperature, constant line voltage, and constant line frequency. Equipment must be operating at a specified ambient condition for a warm-up of one hour before the drift specification is applicable. Drift is specified as a percentage change (may be plus or minus) of base speed, unless otherwise stated. Drift is caused by random changes in operating characteristics of drive components.

### DISPLACEMENT POWER FACTOR

The ratio of the active power of the fundamental wave to the apparent power of the fundamental wave in rms voltamperes. Displacement power factor is the power factor for which electric power utility companies charge penalties for low power factor.

### CALCULATED POWER FACTOR

Expressed by the formula:  $\text{Watts} = 3 \times E_{\text{Line (rms)}} \times I_{\text{Line (rms)}} \times \text{Cos } \theta$  (Power-Factor), represents the ratio of total watts input to total rms voltamperes input. This considers the harmonic content of line input, as well as the fundamental wave of the line, and is always lower than the displacement power factor.

### NEMA DEFINITIONS

Extracted from NEMA Standard (ICS-110)

#### ENCLOSURES DESCRIPTION

NEMA 1	<b>General Purpose – Indoor.</b> Intended for use indoors, primarily to prevent accidental contact of personnel with the enclosed equipment. In addition, they provide protection against falling dirt.
NEMA 3	<b>Dusttight, Raintight and Sleet (Ice) Resistant – Outdoor.</b> Intended for use outdoors to protect the enclosed equipment against windblown dust and water. They are not sleet (ice) proof.
NEMA 3R	<b>Rainproof and Sleet (Ice) Resistant – Outdoor.</b> Intended for use outdoors to protect the enclosed equipment against rain. They are not dust, snow, nor sleet (ice) proof.
NEMA 3S	<b>Dusttight, Raintight and Sleet (Ice) Proof – Outdoor.</b> Intended for use outdoors to protect the enclosed equipment against windblown dust and water and to provide for its operation when the enclosure is covered by external ice or sleet. Does not protect the enclosed equipment against malfunction resulting from internal icing.
NEMA 4	<b>Watertight and Dusttight – Indoor.</b> Intended for use indoors to protect the enclosed equipment against splashing water, seepage of water, falling or hose-directed water, and severe external condensation.
NEMA 4X	<b>Watertight and Dusttight – Indoor.</b> Same provisions as NEMA 4 enclosures and, in addition, are corrosion resistant.
NEMA 5	<b>Superseded by NEMA 12.</b>
NEMA 6	<b>Submersible, Watertight, Dusttight and Sleet (Ice) Resistant – Indoor and Outdoor.</b> Intended for use indoors or outdoors where occasional submersion is encountered.

#### NEMA 12

#### Industrial Use – Dusttight and Driptight – Indoor.

Intended for use indoors to protect the enclosed equipment against fibers, flyings, lint, dust and dirt, and light splashing, seepage, drippings and external condensation of non-corrosive liquids.

#### NEMA 13

#### Oiltight and Dusttight – Indoor.

Intended for use indoors primarily to house pilot devices such as limit switches, foot switches, pushbuttons, selector switches, pilot lights, etc., and to protect these devices against lint and dust, seepage, external condensation, and spraying of water, oil or coolant.

#### ENCLOSURES FOR HAZARDOUS LOCATIONS

#### DESCRIPTION

The term “explosion-proof” has been so loosely applied that NEMA deprecates its use. As defined by the National Electrical Code, the term “explosion-proof” applies only to NEMA 7 and 10 enclosures which, when properly installed and maintained, are designed to contain an internal explosion without causing external hazard.

#### NEMA 7, Class I Group A, B,C, or D

Intended for use indoors, in the atmospheres and locations defined as Class I and Group A, B, C or D in the National Electrical Code. The letters indicate the gas or vapor in the hazardous location.

#### NEMA 9, Class II Group E, F, or G

Intended for use indoors in the atmospheres defined as Class II and Group E, F or G in the National Electrical Code. The letters E, F or G indicate the dust in the hazardous location.

#### NEMA 10

Designed to meet the requirements of the U.S. Bureau of Mines which relate to atmospheres containing mixtures of methane and air, with or without coal dust.