

## Expanded Speed Reduction while Maintaining Operating Efficiency

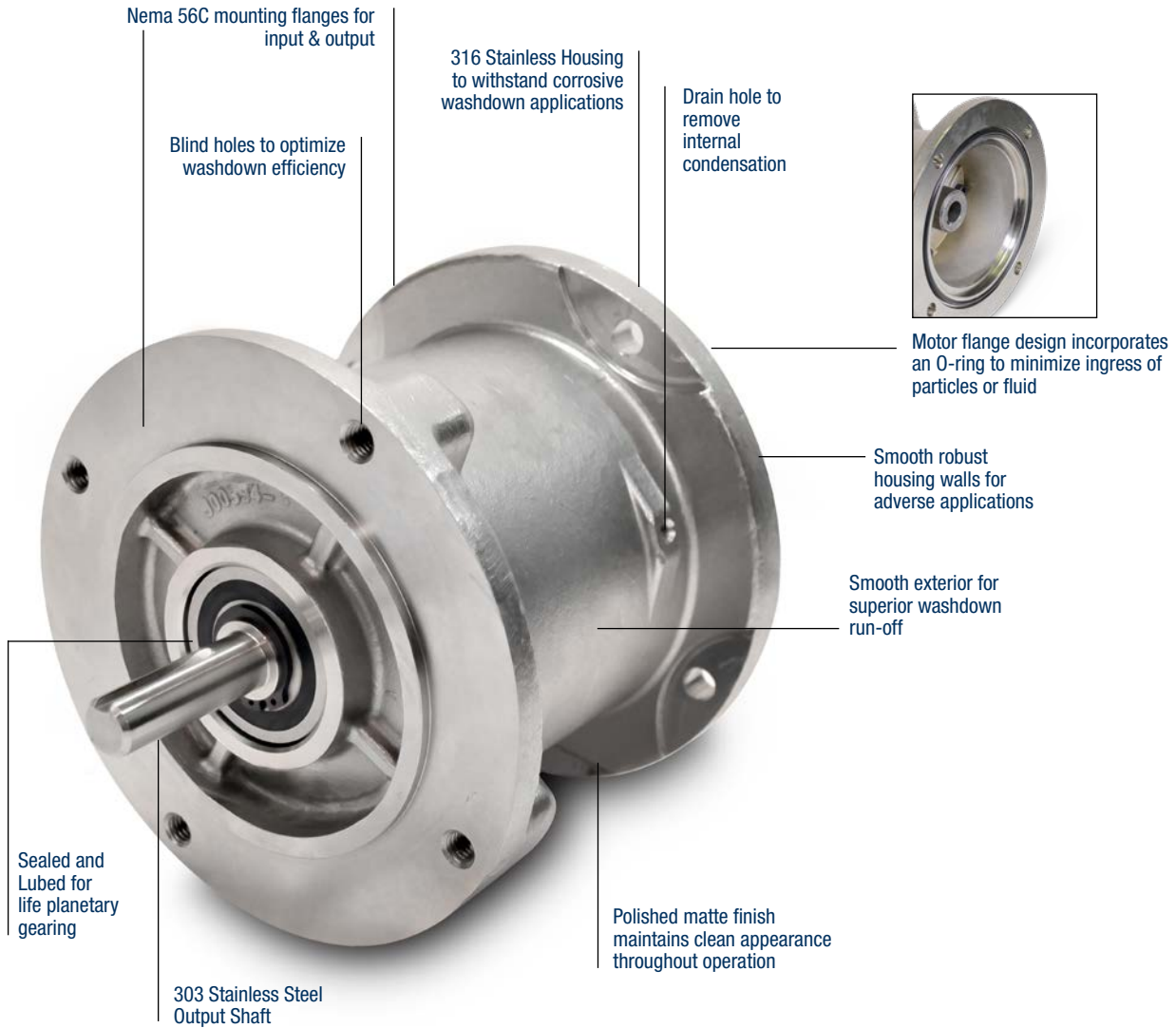

### High Efficiency, Quiet Operation Planetary Gearing

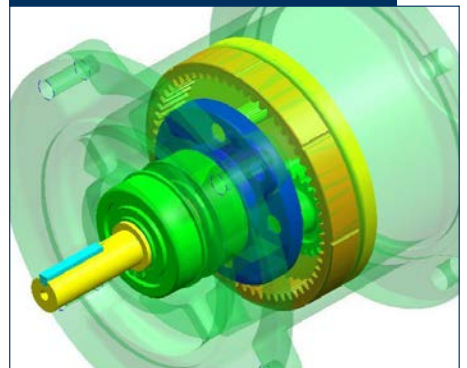

# B3 SSFSP Series Planetary Multiplier

## Ordering Information

**Stainless Steel Stand - Alone Planetary Multiplier** Example: SSFSP-5A

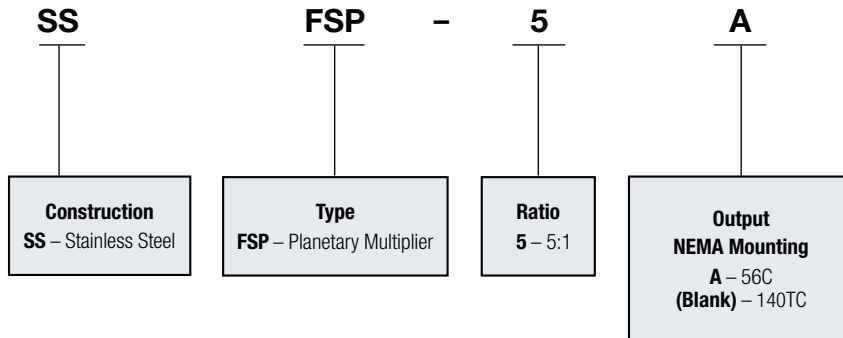

## Lubrication

All SSFSP Series Planetary Multipliers are supplied as Lubricated-for-Life for maximum efficiency, maintenance-free operation. The inherent design of planetary gearing is conducive to the use of grease as a lubricant, because the rotation of the sun and planet gears inside of the internal ring gear promotes even distribution of the lubricant and consistent recirculation. The lubricant we apply at the time of assembly is Klubersynth UH1 14-222 grease which has the characteristics shown below.

LUBRICANT	Type	Operating Temperature Range	Certifications	Comments
Klubersynth UH1 14-222	Synthetic Grease, NLGI2	-15F to +225F (-25C to +107C)	FDA 21CFR178.3570 compliant, NSF registered	H1 Food-Grade

Notes: Temperature limit is dictated by multiplier components and not the lubricant.

## Performance Data

Output RPM	Ratio	Motor HP (1750 RPM Input)	Output		Multiplier Catalog Number
			HP	Torque (lb.ins)	
350	5	1/6	.14	25	SSFSP-5 OR SSFSP-5A
		1/4	.21	38	
		1/3	.29	56	
		1/2	.45	81	
		3/4	.69	124	

## Dimensions

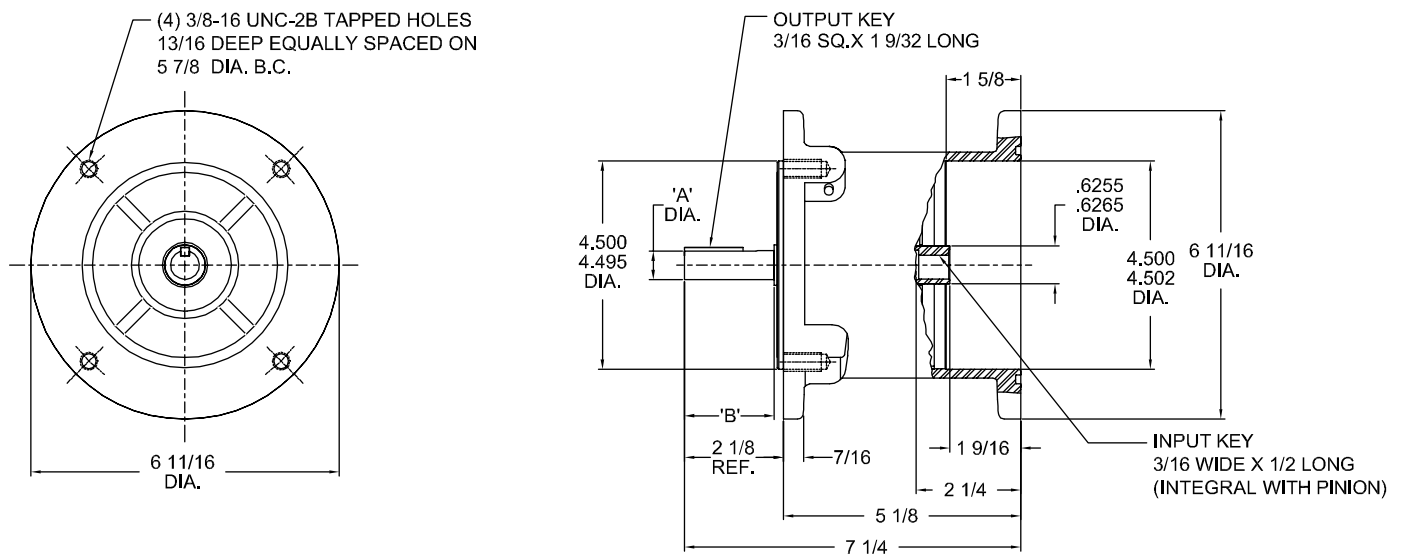

## Dimensions in Inches

Catalog Number	A Shaft Dia.	B Shaft Length	Output NEMA Frame Size	Input NEMA Frame Size
SSFSP-5A	.6245 / .6240	1-15/16	56C	56C
SSFSP-5	.8745 / .8740	2	140TC	56C

