

# Boston Gear®

## Beta Plus / VE Plus

Single-Phase Adjustable-speed DC Motor Controllers

P-3004-BG

*Installation and Operation*

Doc. No. 89522

1/6 - 3 HP



## TABLE OF CONTENTS

<u>SECTION</u>	<u>TITLE</u>	<u>PAGE</u>
I .....	GENERAL INFORMATION .....	1
	Introduction .....	1
	General Description.....	1
	Motor Selection.....	1
	Model Types.....	2
II .....	INSTALLATION.....	3
	Installation Guidelines.....	3
	Installing the Controller .....	5
	Initial Startup.....	17
III .....	OPERATION .....	19
	Power On/Off .....	19
	Run .....	19
	Stop .....	19
	Controlled Stop .....	19
	Zero Speed Detection .....	19
	Speed Control.....	20
	Torque Control .....	20
	Jog .....	20
	Reverse.....	21
	Load Monitor (Motor Timed Overload).....	21
	Current Loop Transducers.....	21
	Armature Voltage and Current Outputs .....	21
	Speed Regulator Input.....	21
	Inoperative Motor.....	21
IV .....	MAINTENANCE AND REPAIR.....	23
	General .....	23
	Adjustment Instructions .....	23
	Troubleshooting Instructions.....	25
V .....	PARTS LIST .....	29
VI .....	RATINGS AND SPECIFICATIONS .....	31
	Ratings.....	31
	Operating Conditions .....	32
	Performance Characteristics.....	32
	Adjustments.....	33
	Specifications .....	33
VII .....	DRAWINGS .....	35
	INDEX .....	39

**LIST OF TABLES**

<u>TABLE</u>	<u>TITLE</u>	<u>PAGE</u>
1.....	Series Beta Plus / VE Plus Model Matrix .....	1
2.....	Jumper J4 Position.....	5
3.....	Dip Switch (SW3) .....	6
4.....	Initial Potentiometer Settings .....	15
5.....	Dynamic Braking Characteristics .....	16
6.....	Troubleshooting.....	21-24
7.....	Parts List, Beta Plus / VE Plus Controllers.....	25
8.....	Typical Application Data .....	27
9.....	Operating Voltages and Signals.....	28
10.....	Controller Weights .....	28
11.....	Speed Regulation Characteristics.....	29
12.....	Shunt Field Data .....	30
13.....	Tachometer Feedback Voltage Selection .....	30

**LIST OF ILLUSTRATIONS**

<u>FIGURE</u>	<u>TITLE</u>	<u>PAGE</u>
1.....	Controller Mounting Configurations .....	7
2.....	Controller Mounting Dimensions .....	8
3.....	Logic Connection Diagram, Run-Stop-Jog Switch.....	9
4.....	Logic Connection Diagram, Forward-Reverse Switch and Run-Stop-Jog Switch .....	9
5.....	Logic Connection Diagram, Run-Stop Pushbuttons and Run-Jog Switch .....	10
6.....	Logic Connection Diagram, Run-Stop-Controlled Stop Pushbuttons and Run-Jog Switch....	10
7.....	Logic Connection Diagram, Optional Unidirectional Contactor Using Run-Jog Switch.....	11
8.....	Logic Connection Diagram, Optional Unidirectional Contactor Using Run-Stop .....	11
	Pushbuttons and Run-Jog Switch	
9.....	Logic Connection Diagram, Optional Armature Contactor Reversing Using Switches.....	12
10.....	Logic Connection Diagram, Optional Armature Contactor Reversing Using Pushbuttons ....	12
	and Run-Jog Switch	
11.....	Logic Connection Diagram, Line Starting With Motor Speed Potentiometer .....	13
12.....	Signal Connection Diagram, Motor Speed Potentiometer.....	13
13.....	Signal Connection Diagram, Tachometer Feedback.....	14
14.....	Signal Connection Diagram, Current (Torque) Reference Potentiometer.....	14
15.....	Signal Connection Diagram, Line Starting Without a Motor Speed Potentiometer .....	14
16.....	Signal Connection Diagram, 4-20mA Interface.....	15
17.....	Signal Connection Diagram, 4-20mA Transducer with Auto/Manual Switch .....	15
18.....	Signal Connection Diagram, Transducer with External Burden Resistor .....	15
19.....	Signal Connection Diagram, PID Controller with Auto/Manual Switch .....	16
20.....	Signal Connection Diagram, 4-20mA Outputs – Armature Amps and Volts.....	16
21.....	Signal Connection Diagram, 0-10Vdc Outputs – Armature Amps and Volts .....	16
22.....	Functional Schematic, Series Beta Plus / VE Plus.....	36
23.....	Series Beta Plus / VE Plus Control Board, 1/6 – 3HP .....	37

Blank Page

## **WARNING**

The following must be strictly adhered to at all times.

1. **YOU AS THE OWNER OR OPERATOR OF FINCOR EQUIPMENT HAVE THE RESPONSIBILITY TO HAVE THE USERS OF THIS EQUIPMENT TRAINED IN ITS OPERATIONS AND WARNED OF ANY POTENTIAL HAZARDS OF SERIOUS INJURY.**
2. **THE DRIVE EQUIPMENT SHOULD BE INSTALLED, OPERATED, ADJUSTED, AND SERVICED ONLY BY QUALIFIED PERSONNEL FAMILIAR WITH THE CONSTRUCTION AND OPERATION OF THE EQUIPMENT AND THE HAZARDS INVOLVED INCLUDING THOSE DESCRIBED BELOW. FAILURE TO OBSERVE THIS WARNING CAN RESULT IN PERSONAL INJURY, LOSS OF LIFE, AND PROPERTY DAMAGE.**
3. **THE NATIONAL ELECTRICAL CODE REQUIRES THAT AN AC LINE FUSED DISCONNECT OR CIRCUIT BREAKER BE PROVIDED IN THE AC INPUT POWER LINES TO THE CONTROLLER. THIS DISCONNECT MUST BE LOCATED WITHIN SIGHT OF THE CONTROLLER. DO NOT OPERATE THE CONTROLLER UNTIL THIS CODE REQUIREMENT HAS BEEN MET.**
4. **THE DRIVE EQUIPMENT IS AT AC LINE VOLTAGE WHENEVER AC POWER IS CONNECTED TO THE DRIVE EQUIPMENT. CONTACT WITH AN ELECTRICAL CONDUCTOR INSIDE THE DRIVE EQUIPMENT OR AC LINE DISCONNECT CAN CAUSE ELECTRIC SHOCK RESULTING IN PERSONAL INJURY OR LOSS OF LIFE.**
5. **BE SURE ALL AC POWER IS DISCONNECTED FROM THE DRIVE EQUIPMENT BEFORE TOUCHING ANY COMPONENT, WIRING, TERMINAL, OR ELECTRICAL CONNECTION IN THE DRIVE EQUIPMENT.**
6. **ALWAYS WEAR SAFETY GLASSES WHEN WORKING ON THE DRIVE EQUIPMENT.**
7. **DO NOT REMOVE OR INSERT CIRCUIT BOARDS, WIRES, OR CABLES WHILE AC POWER IS APPLIED TO THE DRIVE EQUIPMENT. FAILURE TO OBSERVE THIS WARNING CAN CAUSE DRIVE DAMAGE AND / OR PERSONAL INJURY.**
8. **ALL DRIVE EQUIPMENT ENCLOSURES, MOTOR FRAMES, AND REMOTE OPERATOR STATIONS MUST BE CONNECTED TO AN UNBROKEN COMMON GROUND CONDUCTOR. AN UNBROKEN GROUNDING CONDUCTOR MUST BE RUN FROM THE COMMON GROUND CONDUCTOR TO A GROUNDING ELECTRODE BURIED IN THE EARTH OR ATTACHED TO A PLANT GROUND. REFER TO THE NATIONAL ELECTRICAL CODE AND LOCAL CODES FOR GROUNDING REQUIREMENTS.**
9. **THE ATMOSPHERE SURROUNDING THE DRIVE EQUIPMENT MUST BE FREE OF COMBUSTIVE VAPORS, CHEMICAL FUMES, OIL VAPOR, AND ELECTRICALLY CONDUCTIVE OR CORROSIVE MATERIALS.**
10. **SOLID-STATE DEVICES IN THE CONTROLLER CAN BE DESTROYED OR DAMAGED BY STATIC ELECTRICITY. THEREFORE, PERSONNEL WORKING NEAR THESE STATICSENSITIVE DEVICES MUST BE APPROPRIATELY GROUNDED.**

## SECTION I

### GENERAL INFORMATION

#### INTRODUCTION

This manual contains installation, operation, and maintenance and repair instructions for Series Beta Plus / VE Plus Single-Phase Adjustable-Speed DC Motor Controllers. A parts list, ratings and specifications, and drawings are also included.

#### GENERAL DESCRIPTION

Series Beta Plus / VE Plus Controllers statically convert AC line power to regulated DC for adjustable-speed armature control of shunt-wound and permanent-magnet motors.

Series Beta Plus / VE Plus Controllers comply with applicable standards established by the National Electrical Code and NEMA for motor and industrial control equipment. The controllers are Underwriters Laboratories Listed (File No. E184521) UL/cUL.

#### MOTOR SELECTION

Series Beta Plus / VE Plus Controllers control the operation of general purpose DC motors designed for use with solid-state rectified power supplies. The motor may be shunt-wound, stabilized shunt-wound, or permanent magnet. For maximum efficiency, the motor should be rated for operation from a NEMA Code K power supply.

**MODEL TYPES**

**TABLE 1. Beta Plus / VE Plus Model Matrix**

Item Code	Cat. No.	Line Voltage HP Range <sup>a</sup>		Construction			Function				Operator's Controls		Wiring Diagram Figure #	
		115 VAC	230 VAC	Angle Bracket Chassis	Open Chassis	Enclosed	Run / Stop	Arm Cont Run/Stop w/ DB	Arm Switch Rev	Arm Cont Rev w/ DB	Local (Integral)	Remote		
64883	VES3	1/6 - 1	1/2 - 3		X		X					X	3, 5, 6	
57904	VES3U				X			X					X	7, 8
64584	VES3M				X					X			X	9, 10
64885	VES3B						X	X					X	3, 5, 6
57910	VES3UB						X		X				X	7, 8
64887	VES3MB						X				X		X	9, 10
64886	VES3S							X	X			X		3
57930	VES3US							X		X		X		7
64884	VES3MR							X			X	X		9
64874	RBS2	1/6 - 1	1/2 - 2		X		X					X	3, 5	
57848	RBS2C			X			X						X	3, 5
57894	RBS2U				X				X				X	7, 8
57899	RBS2CU				X			X					X	7, 8
64878	RBS2M				X						X		X	9, 10
57903	RBS2CM				X						X		X	9, 10
64875	RBS2B						X	X					X	3, 5
13184	RBS2B-WD						X <sup>b</sup>	X					X	3, 5
57896	RBS2UB						X		X				X	7, 8
13280	RBS2UB-WD						X <sup>b</sup>		X				X	7, 8
64879	RBS2MB						X				X		X	9, 10
13324	RBS2MB-WD						X <sup>b</sup>				X		X	9, 10
64876	RBS2S						X	X				X		3
13380	RBS2S-WD						X <sup>b</sup>	X				X		3
64877	RBS2B						X				X		X	4
13362	RBS2B-WD						X <sup>b</sup>				X		X	4
57897	RBS2US						X		X				X	7
13364	RBS2US-WD						X <sup>b</sup>		X				X	7
64880	RBS2MR						X				X	X		9
13378	RBS2MR-WD						X <sup>b</sup>				X	X		9
64881	RBS3	1/6 - 1	1/2 - 3		X		X					X	3, 5	
57895	RBS3U				X			X					X	7, 8
64882	RBS3M				X						X		X	9, 10

- a. Units are reconnectable
- b. Units are washdown duty

## SECTION II

### INSTALLATION

Before starting the installation, read this section thoroughly. In addition, a thorough review of the Ratings and Specifications (Section VI) is recommended. The following installation guidelines should be kept in mind when installing the controller.

#### INSTALLATION GUIDELINES

**1. CONTROLLER MOUNTING** - The controller may be mounted either vertically or horizontally. However, never mount the controller upside down, immediately beside or above heat generating equipment, or directly below water or steam pipes.

The controller must be mounted in a location free of vibration.

Multiple controllers may be mounted side by side, as close to each other as the mounting feet will allow.

The minimum clearance at the top and bottom of the controller may be as narrow as the conduit fittings allow.

**2. ATMOSPHERE** - The atmosphere surrounding the controller must be free of combustible vapors, chemical fumes, oil vapor, and electrically conductive or corrosive materials.

The air surrounding an enclosed controller must not exceed 40 degrees C (104 degrees F), and the air surrounding an open-chassis controller must not exceed 55 degrees C (131 degrees F). Minimum air temperature is 0 degree C (32 degrees F) for enclosed and open-chassis controllers.

**3. CONTROLLER CONSTRUCTION** - The controller base is made of die-cast aluminum with a powdered epoxy finish, and the cover is made of a die-cast aluminum alloy.

The controller enclosure is totally enclosed, non-ventilated, and complies with NEMA Type 4 and 12 standards. There is an oil resistant synthetic rubber gasket between the cover and base. Those models with integral operator controls include flexible boots to seal the switches, and a seal for the MOTOR SPEED potentiometer.

**4. LINE SUPPLY** - The controller should not be connected to a line supply capable of supplying more than 100,000 amperes short-circuit current. Short-circuit current can be limited by using an input supply transformer of 50 KVA or less, or by using correctly sized current limiting fuses in the supply line ahead of the controller. Do not use a transformer with less than the minimum transformer KVA listed in Table 8, page 31.

If rated line voltage is not available, a line transformer will be required. If the line supply comes directly from a transformer, place a circuit breaker or disconnect switch between the transformer secondary and the controller. If power is switched in the transformer primary, transients may be generated which can damage the controller. See Table 8 (page 31) for minimum transformer KVA.

Do not use power factor correction capacitors on the supply line to the controller.

A 20 Joule metal oxide varistor (MOV) is connected across the controller terminals. If higher energy transients are present on the line supply, additional transient suppression will be required to limit transients to 150% of peak line voltage.



## Beta Plus / VE Plus

When a 115 VAC line supply is used, connect the white (common) wire to Terminal L2 and connect the remaining (hot) wire to Terminal L1.

**5. ISOLATION TRANSFORMER** - While not required, an isolation transformer can provide the following advantages:

- a. Reduce the risk of personal injury if high voltage drive circuits are accidentally touched.
- b. Provide a barrier to externally generated AC supply transients. This can prevent controller damage from abnormal line occurrences.
- c. Reduce the potential for damaging current if the motor armature, motor field, or motor wiring becomes grounded.

**6. GROUNDING** - Connect the green or bare (ground) wire of the line supply to the ground screw located near the top conduit entry hole in the controller base. Then ground the controller base by connecting the ground screw to earth ground.

The motor frame and operator control stations must also be grounded.

**Personal injury may occur if the controller, motor, and operator stations are not properly grounded.**

**7. WIRING PRACTICES** - The power wiring must be sized to comply with the National Electrical Code, CSA, or local codes. Refer to the controller data label for line and motor current ratings.

**Do not use solid wire.**

Signal wiring refers to wiring for potentiometers, tachometer generators, and transducers. Control wiring refers to wiring for operator controls, e.g., switches and pushbuttons. Signal and control wiring may be run in a common conduit, but not in the same conduit as the power wiring. In an enclosure, signal and control wiring must be kept separated from power wiring and only cross at a 90 degree angle to reduce electrical noise.

If shielded wire (such as Alpha 2422 - two conductor, 2423 - three conductor, 2424 - four conductor) is used for the signal and control wiring, connect the shields to chassis ground (ground screw on the controller base) and tape the opposite ends of the shields. Twisted cable is also suitable for signal and control wiring.

Two 3/4-14 NPT threaded holes are provided for conduit entry, one each in the top and bottom of the controller.

**INSTALLING THE CONTROLLER**

1. Remove the controller front cover (if used) by removing the four cover screws.
2. Check components in the controller for shipping damage. Report shipping damage to the carrier.
3. Check the controller and motor data labels to be sure the units are electrically compatible.
4. Be sure the controller has been calibrated correctly for the motor being used. Calibration is performed by changing the position of a Jumper J4 on the controller control board to comply with Table 2. To change the position of Jumper J4, pull the jumper from the control board and then push it onto the appropriate two pins on the board. For the location of J4, see Figure 23 (page 37).

**TABLE 2. JUMPER J4 POSITION**

JUMPER POSITION <sup>a</sup>	MOTOR ARMATURE CURRENT RATING (AMPERES)	
	2 HP Maximum	3 HP Maximum
100%	10	15
80%	8	12
60%	6	9
40%	4	6
20%	2	3

a. Select the position closest to the motor nameplate armature current rating.

5. Check the positions of Jumpers J1, J2, and J3 on the control board. For the locations of J1, J2, and J3, see Figure 23, page 37. For a 230 VAC line supply and a 180V armature motor, Jumper J1 must be in the 230V position, and Jumpers J2 and J3 must be in the 180V position. For a 115 VAC line supply and a 90V armature motor, J1 must be in the 115V position, and J2 and J3 must be in the 90V position. To change the position of J1, J2, or J3 pull the jumper from the control board and then push it onto the appropriate pins on the board.

NOTE: If Option 1001 (Armature Contactor, Unidirectional), 1004 (Armature Contactor, Reversing), or 1775 (Signal Interface) is to be installed in the controller, do not offset the five-position plug (supplied with the option) at Connector J1 on the control board. Do not confuse Connector J1 with Jumper J1. Refer to the Instruction Sheet (ISP0703, ISP0666, ISP0653, respectively) supplied with the option for connection instructions.

6. The controller may be surface mounted or panel mounted as shown in Figure 1, page 7. Mount the controller. Mounting dimensions are shown in Figure 2, page 8.
7. Conduit entry is made by punching out the knockout at the top or bottom of the controller base. To prevent component damage from knockout fragments, apply masking tape to the inside of the knockout before punching.
8. Connect the power wiring to Terminals L1, L2, A1 (+), A2 (-), F+ and F-. Be sure to observe Installation Guidelines 4 and 7 on pages 3 and 4. If half-wave shunt field voltage is desired, connect one of the motor shunt field leads to Terminal F/2 (see Table 12 on page 34).

NOTE: Low inductance motors require a full-wave field to prevent current instability.

Beta Plus / VE Plus

9. If the controller contains any options that require external wiring, follow the wiring instructions in the instruction sheet supplied with the option.
10. If remote operator control wiring and/or signal wiring is required, connect the controller as shown in the appropriate connection diagram (Figures 3 through 21). Figures 3 through 11 show operator control connections, and Figures 12 through 21 show signal connections.
11. The controller can be programmed for various applications by throwing switches on dip switch SW3

**TABLE 3. DIP SWITCH (SW3)**

<b>FACTORY DEFAULT SETTING IS ALL SWITCHES "ON"</b>		
<b>Switch Position</b>		
<b>1</b>	<b>ON</b> <b>OFF</b>	Low voltage (3Vdc - 30Vdc) tachometer scaling High voltage (31 Vdc - 175Vdc) tachometer scaling.
<b>2</b>	<b>ON</b> <b>OFF</b>	Selects internal burden resistor for 4-20ma input. Selects 0 to 5V speed reference input or external burden resistor (i.e. 10 to 50ma)
<b>3</b>	<b>ON</b> <b>OFF</b>	Selects internal current (torque) reference pot. Selects use of an external current (torque) reference pot.
<b>4</b>	<b>ON</b> <b>OFF</b>	Selects Min Speed pot adjustment. Selects Offset adjustment (for 4-20ma input) with Min Speed pot.
<b>5</b>	<b>ON</b> <b>OFF</b>	Selects anti-restart mode. Prevents controller from restarting automatically after an AC line power interruption. Disables anti-restart mode. Used for line starting applications (jumper TB2:9 to TB2:8 to enable drive).

12. Install the controller cover, if used.

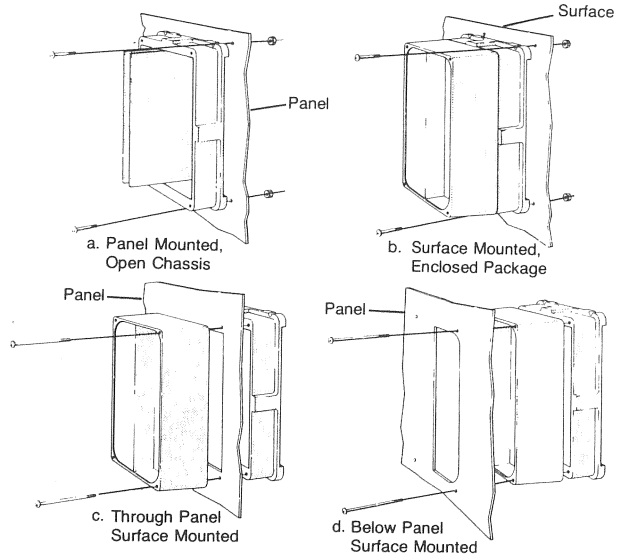

**FIGURE 1. CONTROLLER MOUNTING CONFIGURATIONS**

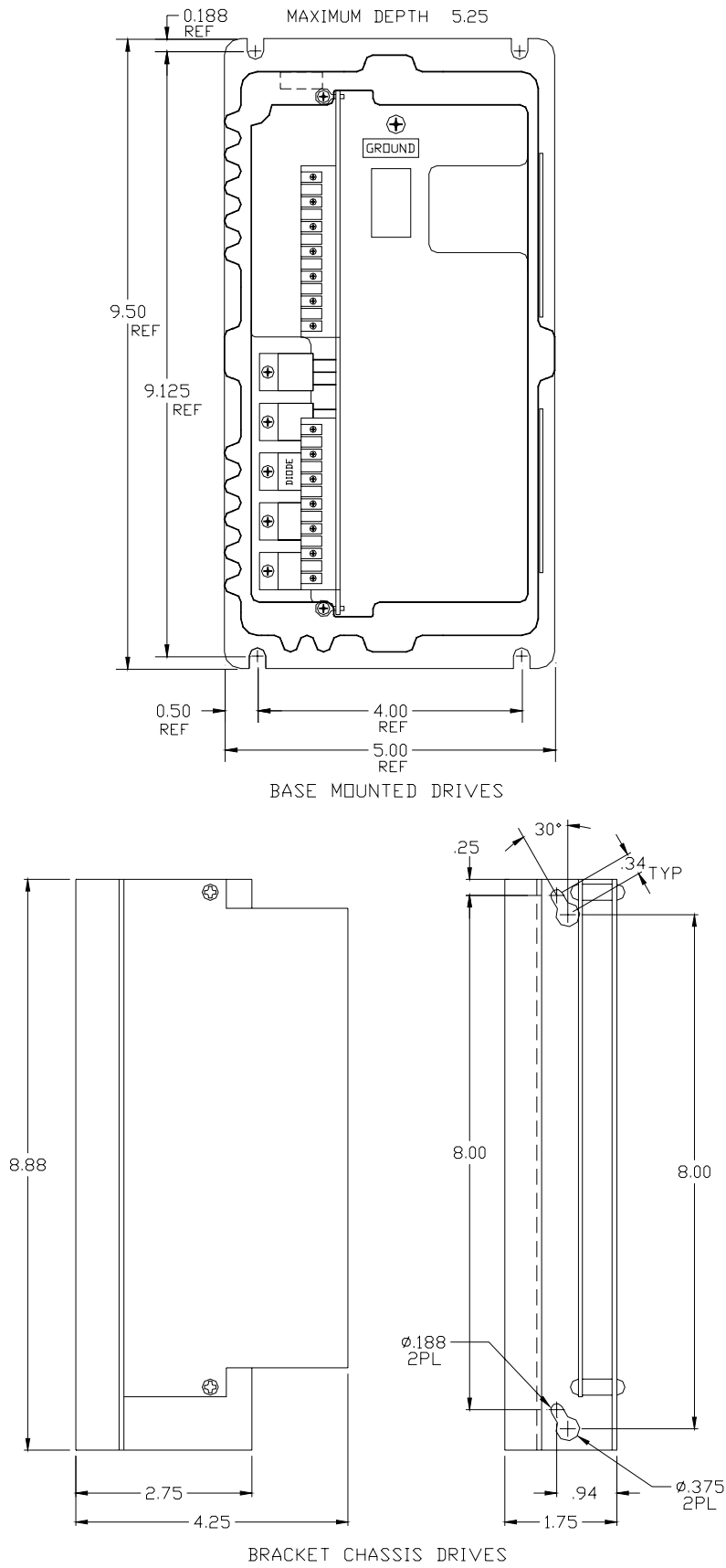

**FIGURE 2. CONTROLLER MOUNTING DIMENSIONS**

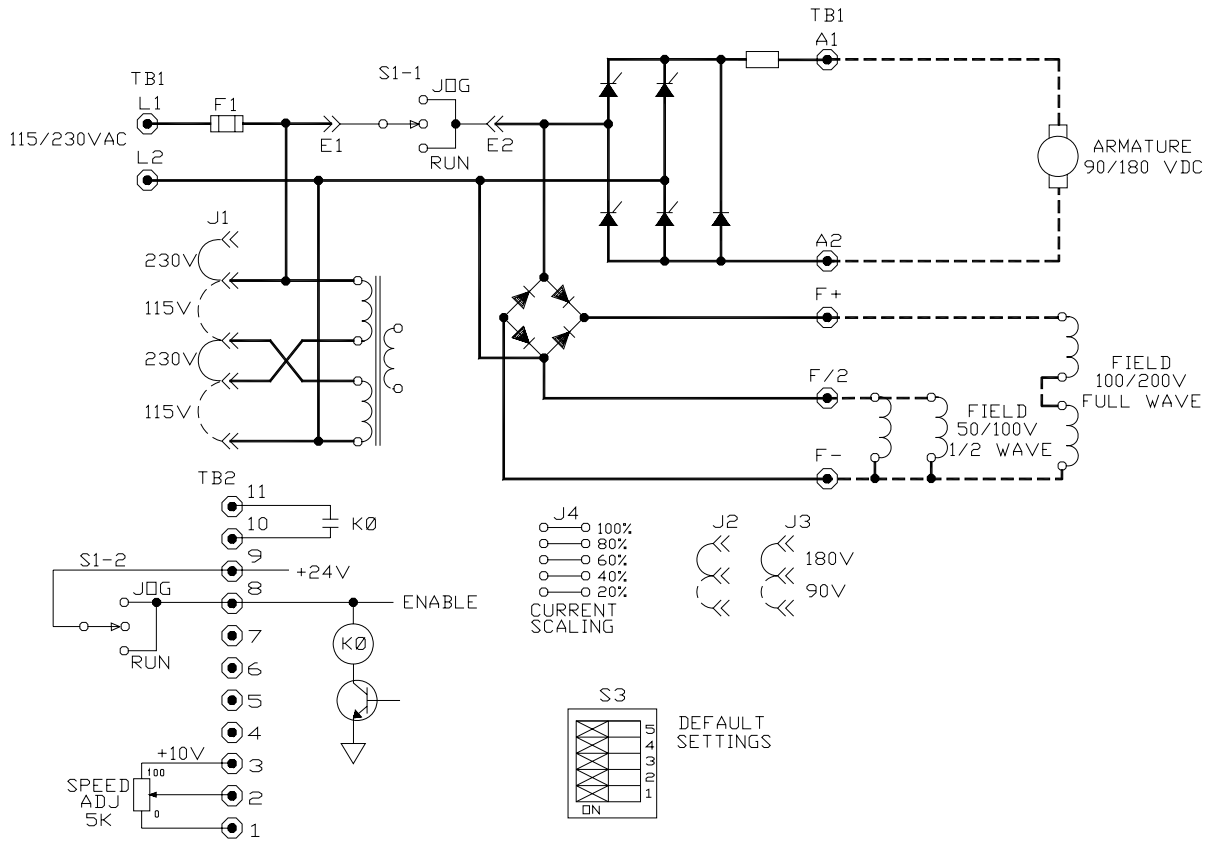

Figure 3. Logic connection diagram, Run-Stop-Jog Switch

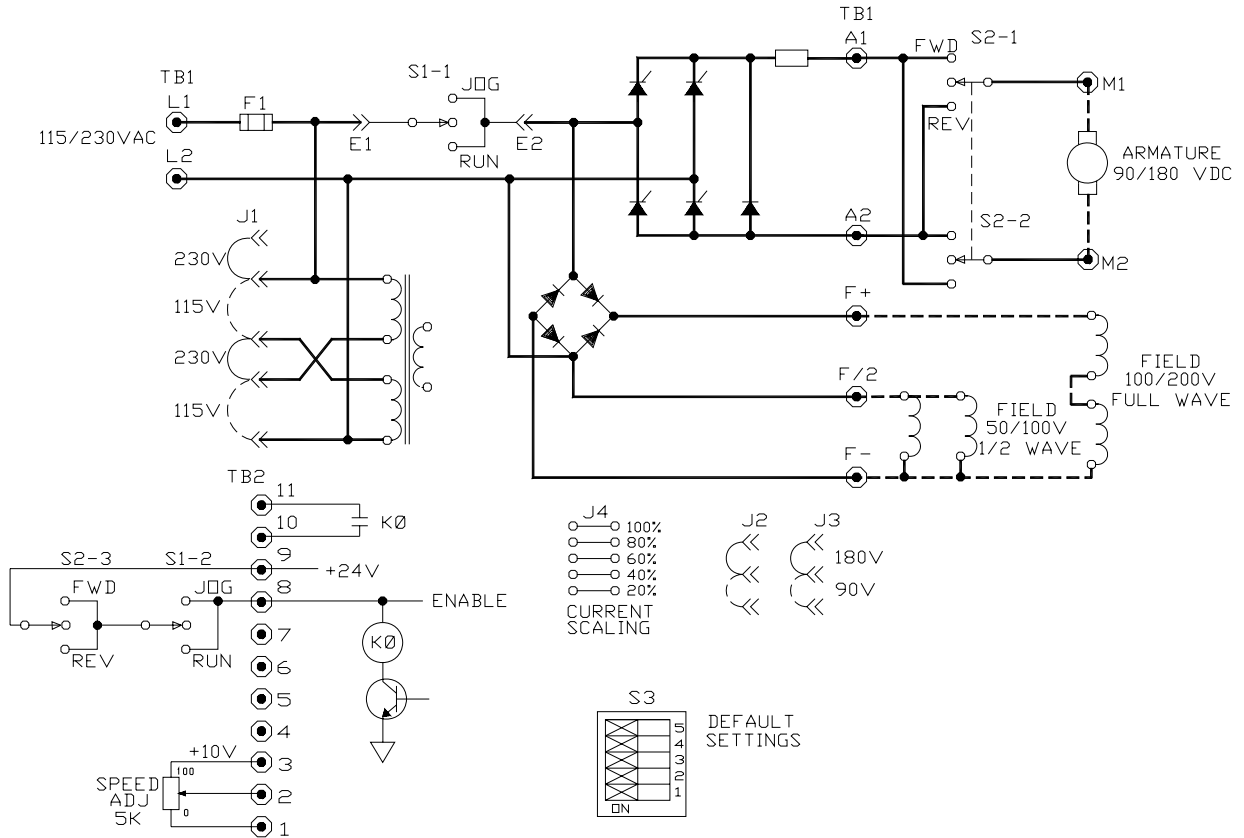

Figure 4. Logic connection diagram, Forward-Reverse Switch and Run-Stop-Jog Switch

Beta Plus / VE Plus

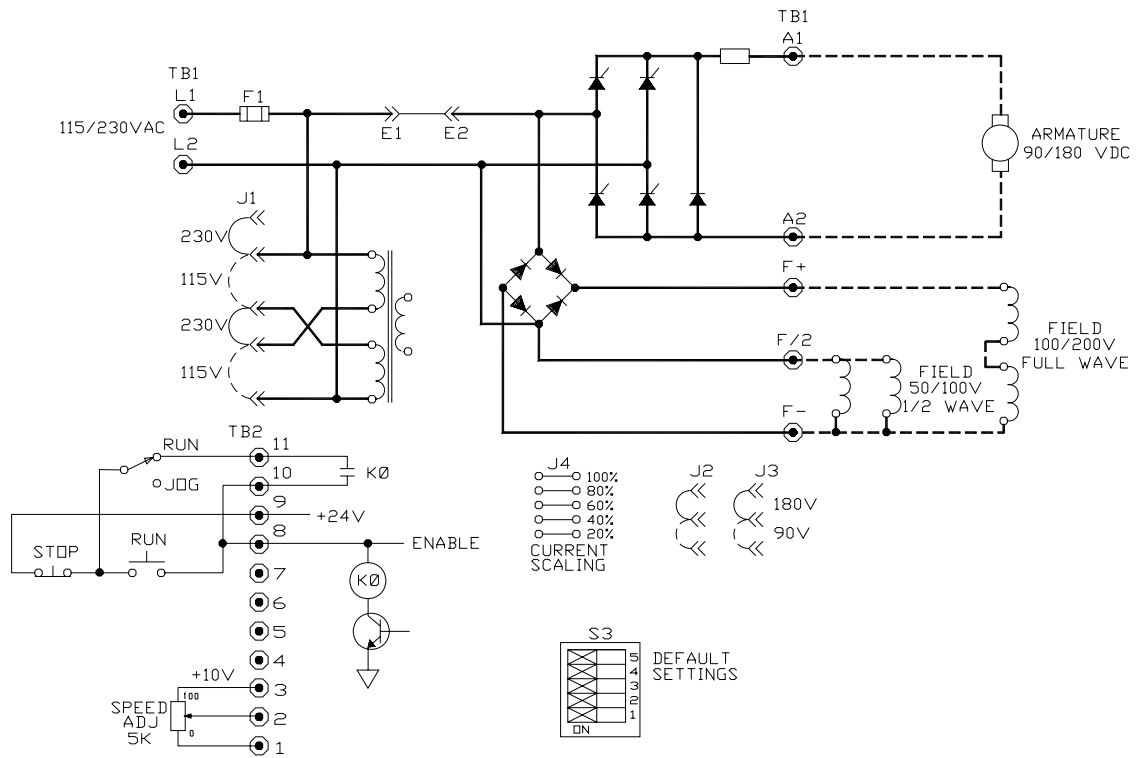

Figure 5. Logic connection diagram, Run-Stop Pushbuttons and Run-Jog Switch

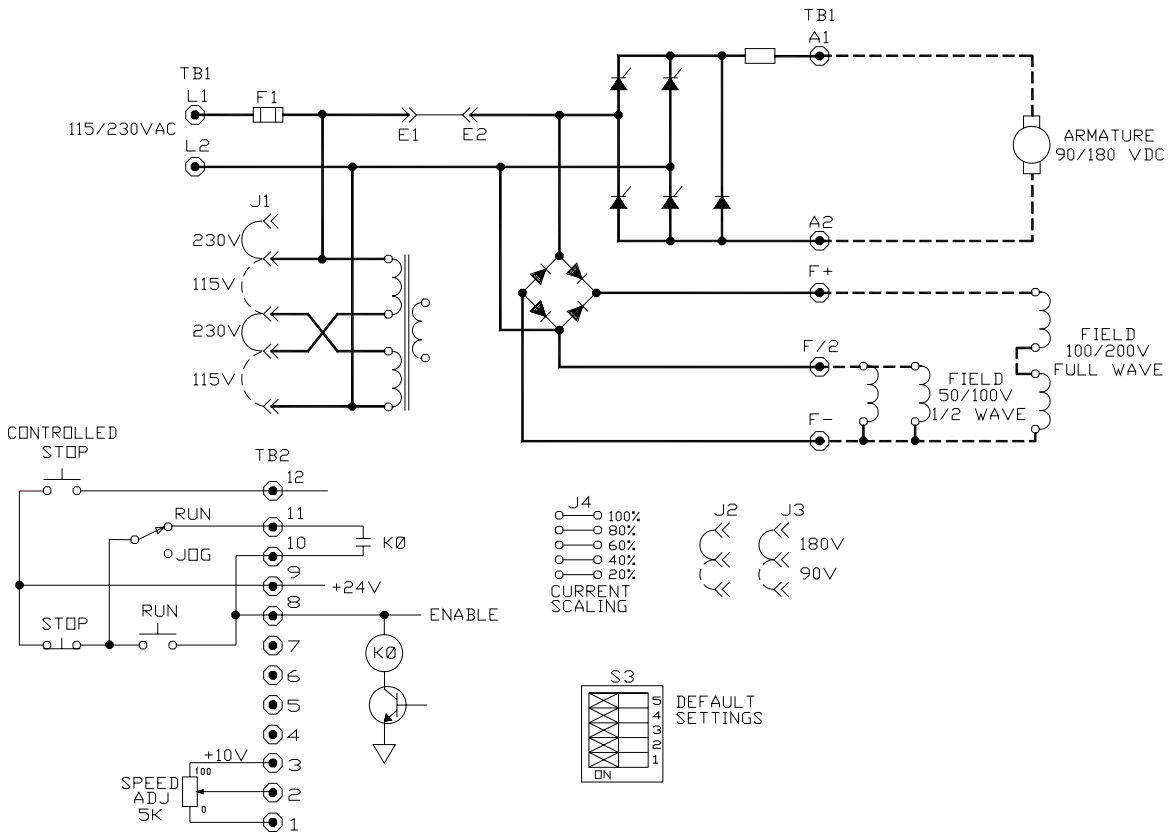

Figure 6. Logic connection diagram, Run-Stop-Controlled Stop Pushbuttons and Run-Jog Switch

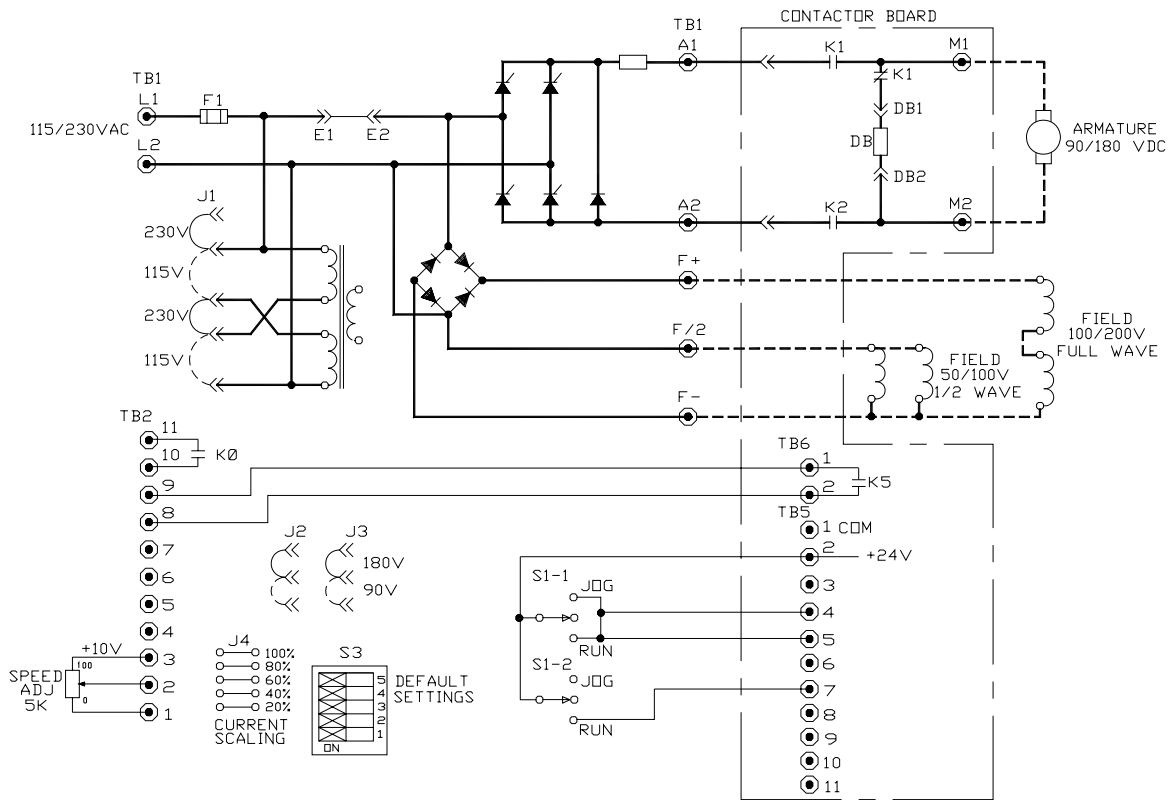

Figure 7. Logic connection diagram, Optional Unidirectional Contactor using Run-Jog Switch

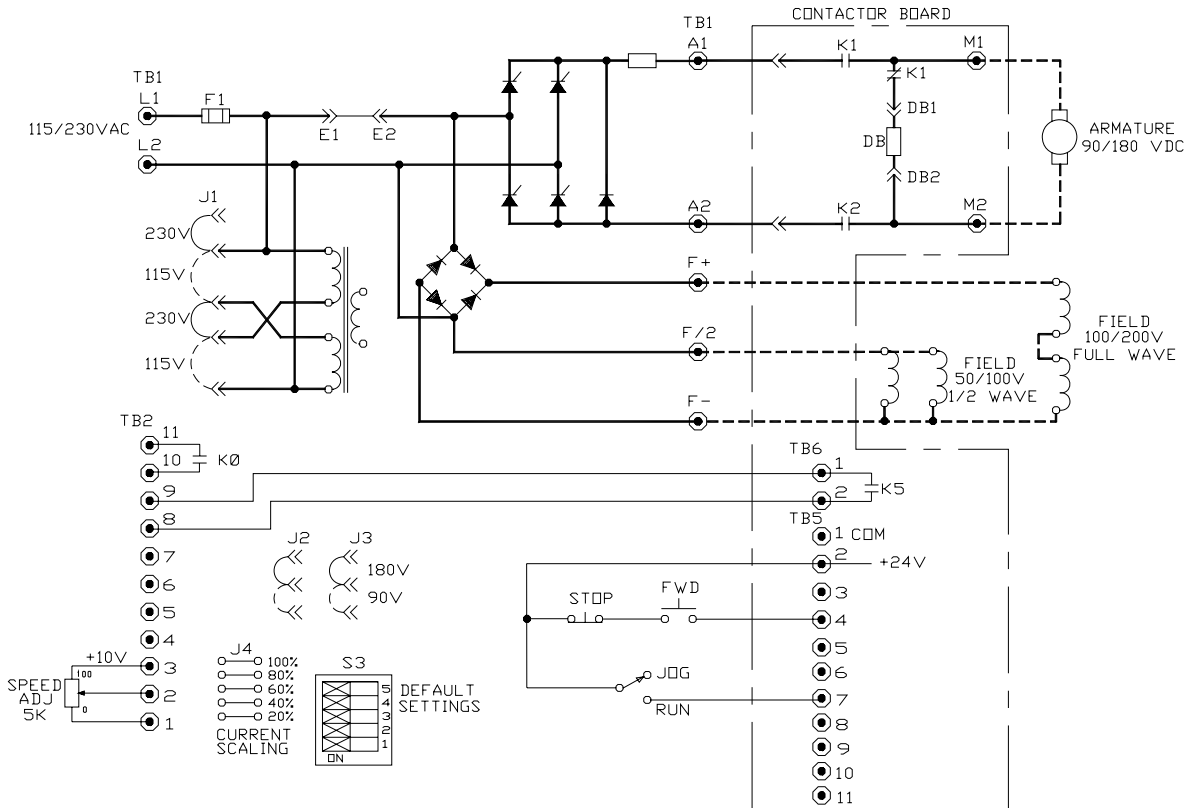

Figure 8. Logic connection diagram, Optional Unidirectional Contactor using Run-Stop Pushbuttons and Run-Jog Switch



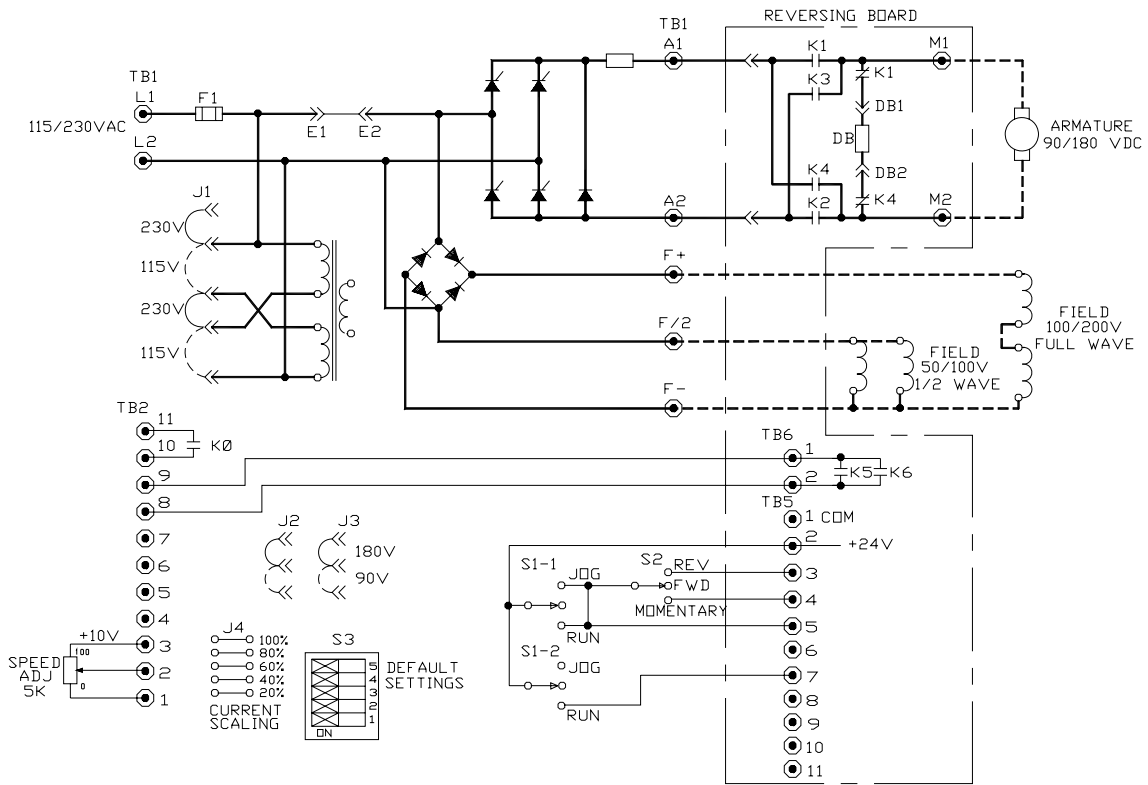

Figure 9. Logic connection diagram, Optional Armature Contactor Reversing using Switches

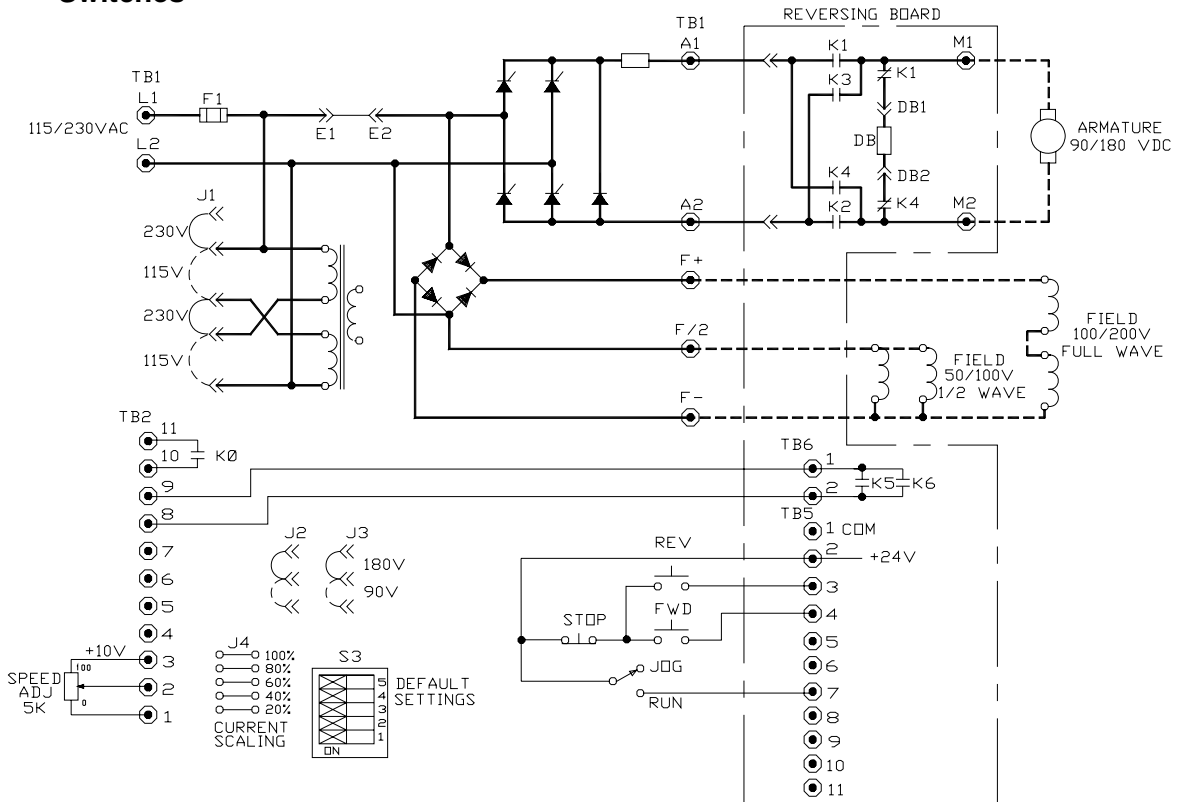

Figure 10. Logic connection diagram, Optional Armature Contactor Reversing using Pushbuttons and Run-Jog Switch

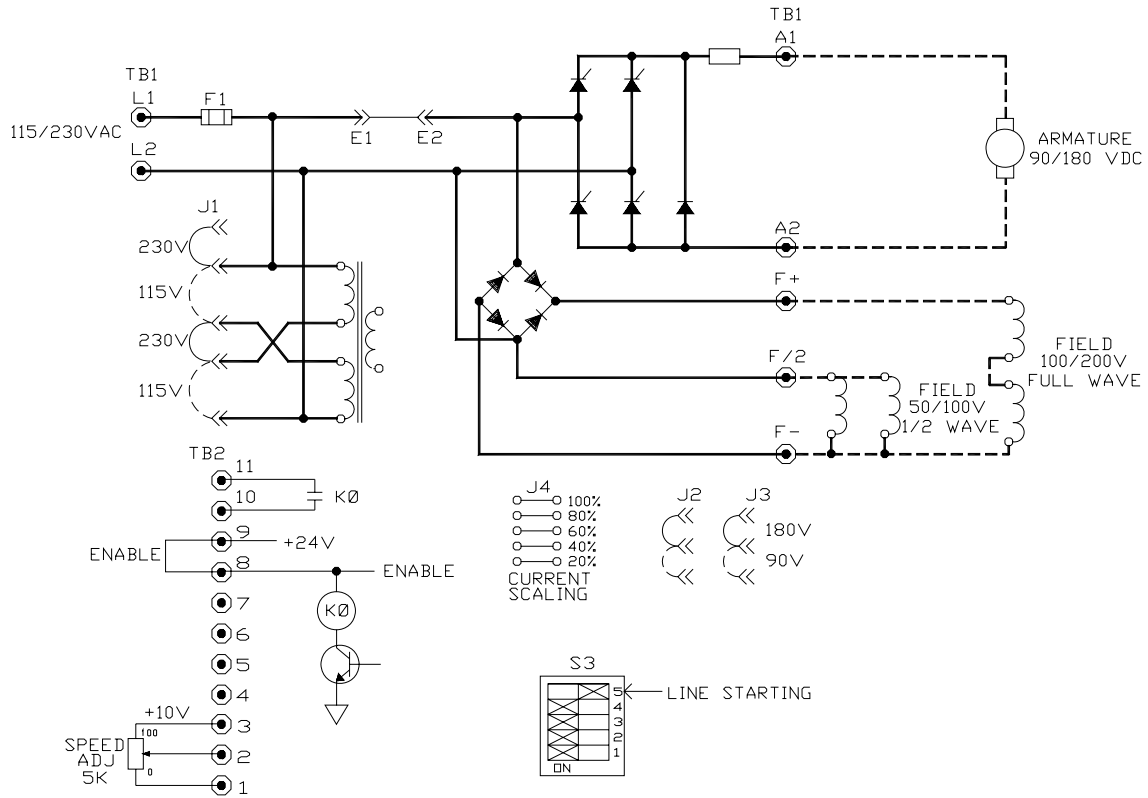

Figure 11. Logic connection diagram, Line Starting with Motor Speed Potentiometer

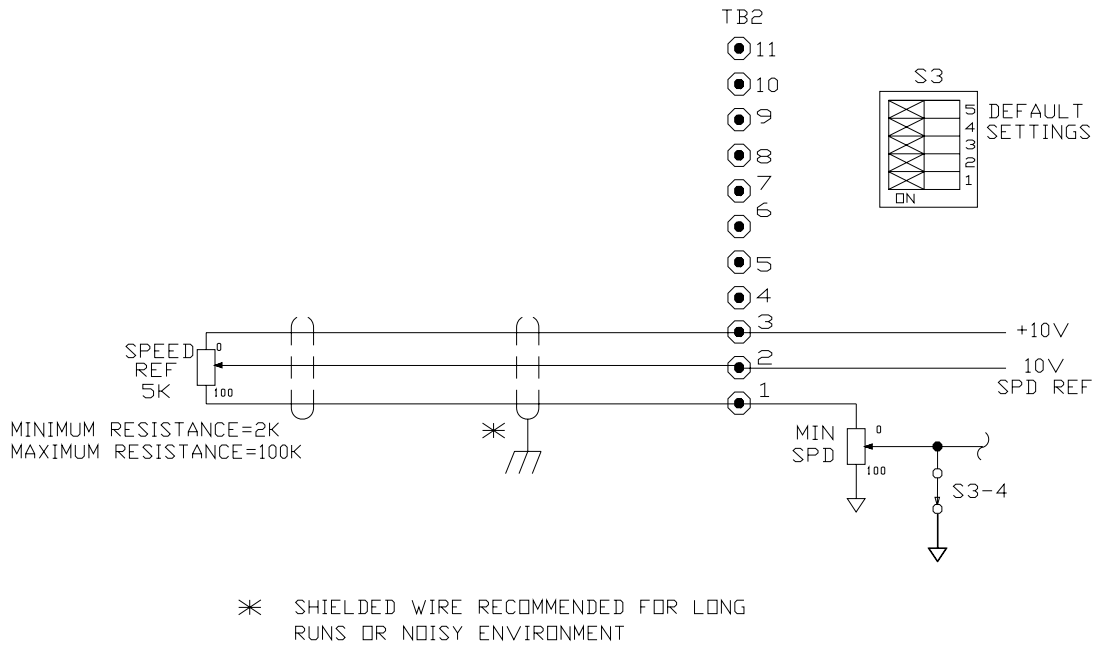

Figure 12. Signal Connection Diagram, Motor Speed Potentiometer

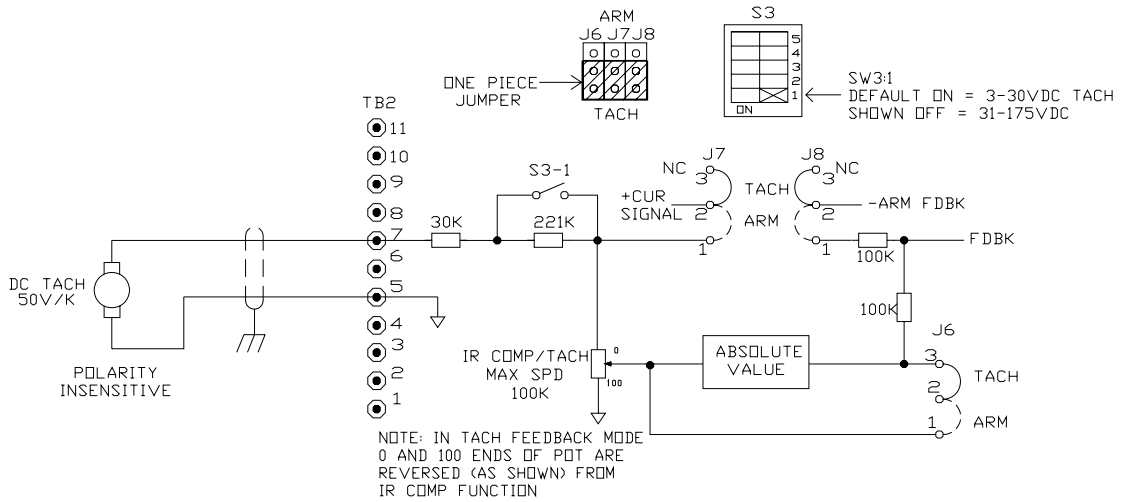

Figure 13. Signal Connection Diagram, Tachometer Feedback

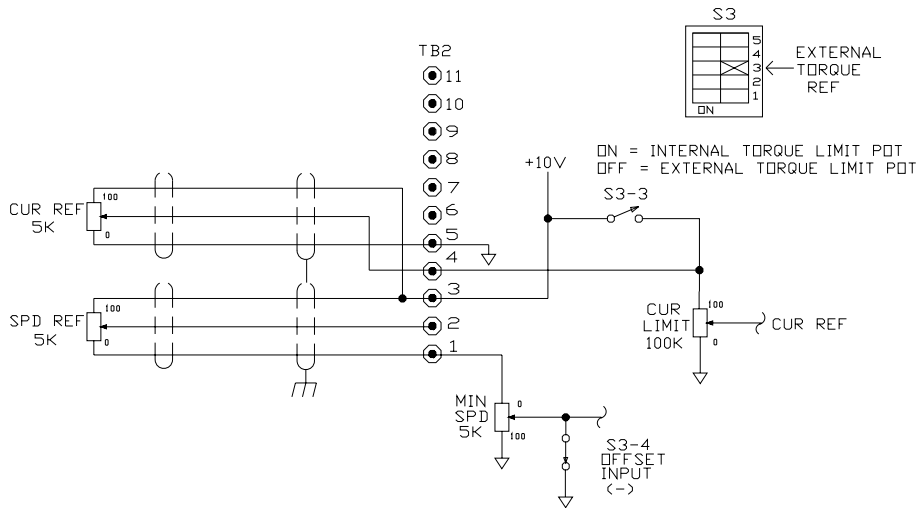

Figure 14. Signal Connection Diagram, Current (Torque) Reference Potentiometer

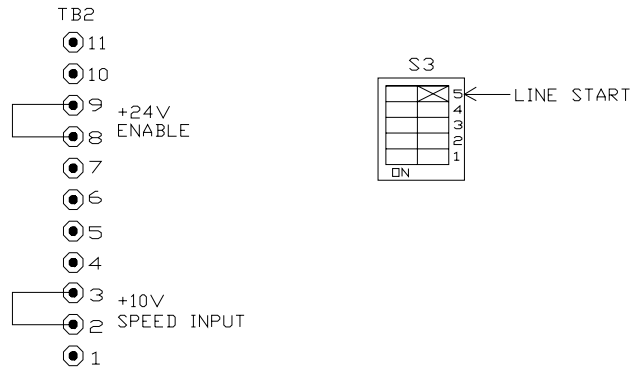

Figure 15. Signal Connection Diagram, Line Starting Without a Motor Speed Potentiometer

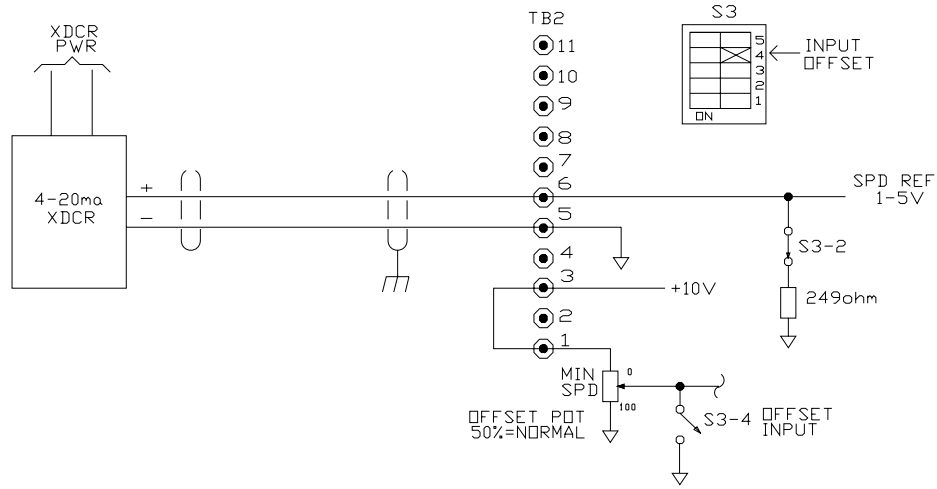

Figure 16. Signal Connection Diagram, 4-20mA Interface

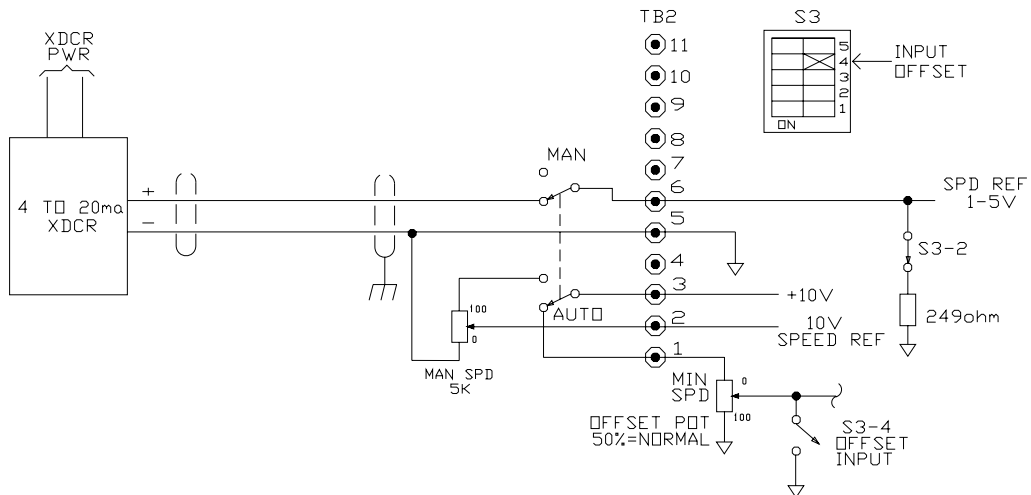

Figure 17. Signal Connection Diagram, 4-20mA Transducer with Manual/Auto Switch

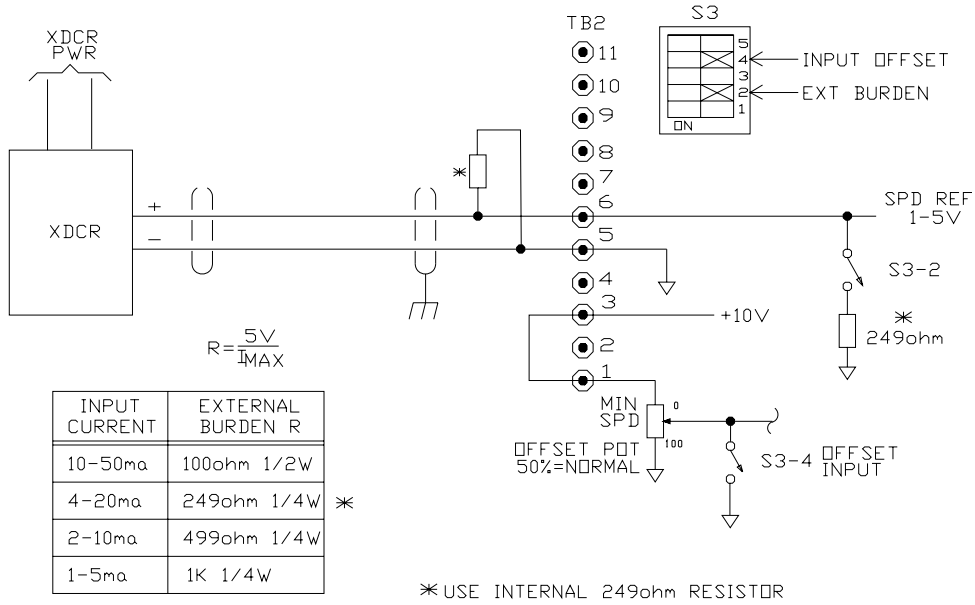

Figure 18. Signal Connection Diagram, Transducer with External Burden Resistor

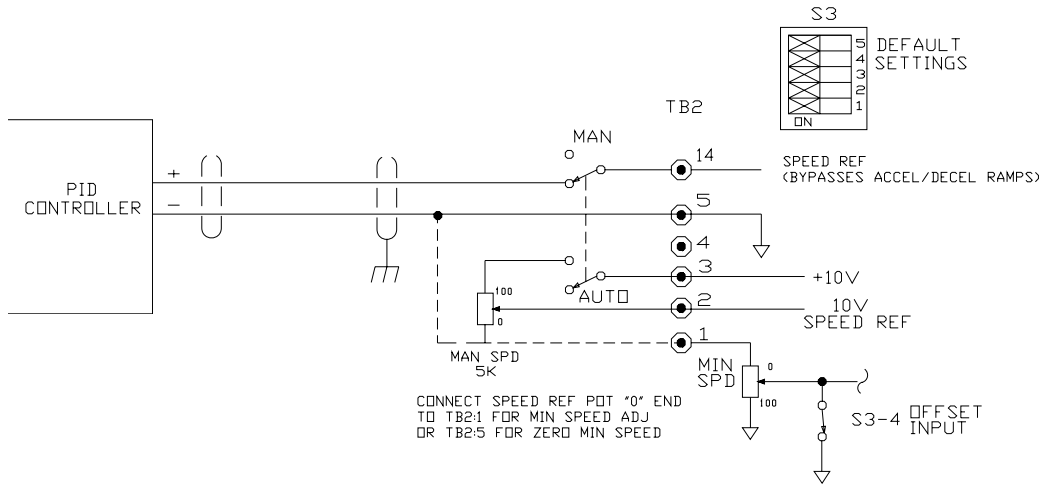

Figure 19. Signal Connection Diagram, PID Controller with Auto/Manual Switch

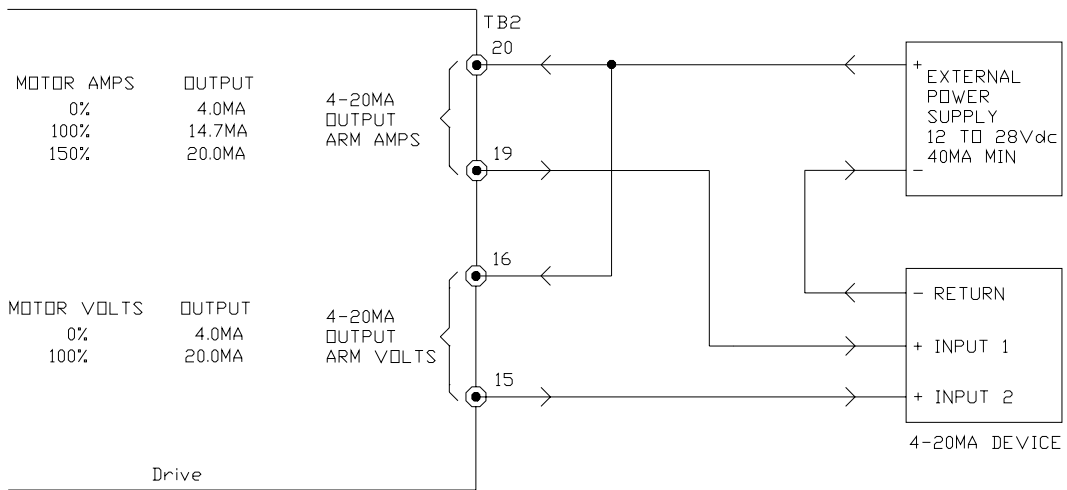

Figure 20. Signal Connection Diagram, 4-20mA Outputs – Armature Amps and Volts

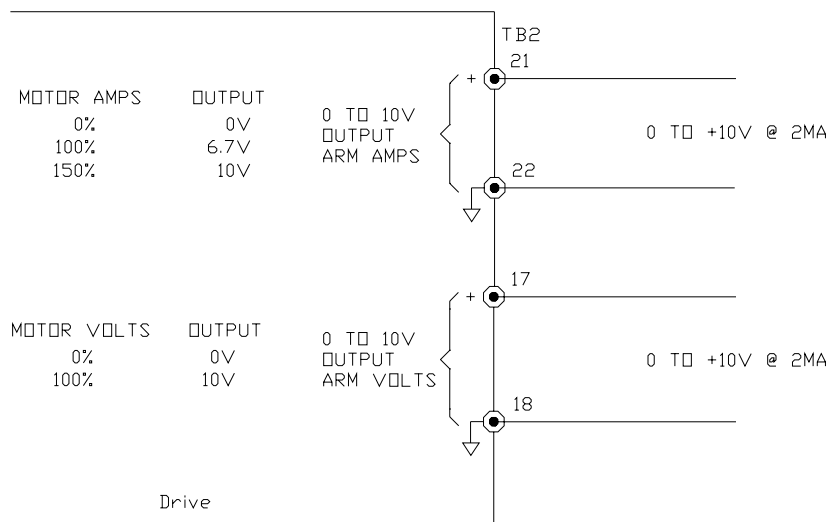

Figure 21. Signal Connection Diagram, 0 to 10Vdc Outputs – Armature Amps and Volts

**INITIAL STARTUP**

1. Open the controller cover (if used) by removing the four cover screws.
2. Be familiar with all options installed in the controller by reviewing the instruction sheets supplied with the options.
3. Be sure all wiring is correct and all wiring terminations are tightened securely.
4. Be sure the controller is calibrated correctly. See steps 4 and 5 under “Installing The Controller” on page 5. Be sure the AC supply voltage to the controller agrees with the controller data label.
6. The potentiometers in the controller are factory adjusted as shown in Table 4. These settings will provide satisfactory operation for most applications. If different settings are required, refer to “Adjustment Instructions” starting on page 23

**TABLE 4. INITIAL POTENTIOMETER SETTINGS**

POTENTIOMETER	SETTING	DESCRIPTION
ACCEL	1/3 Turn Clockwise	10 Seconds
CUR LMT	Fully Clockwise (100%)	150% Load
DECEL	1/3 Turn Clockwise	10 Seconds
IR/TACH	Fully Counterclockwise (0%)	0% Boost
MAX SPD	3/4 Turn Clockwise	100% Speed
MIN SPD	Fully Counterclockwise (0%)	0% Speed
SPD STAB	1/2 Turn Clockwise	Nominal Gain
CUR STAB	1/2 Turn Clockwise	Nominal Gain

7. If the controller has a cover, place it on the controller and secure it with the four cover screws.
8. Turn-on the AC supply to the controller.
9. Check motor rotation, as follows:
  - a. If a MOTOR SPEED potentiometer is used, turn it fully counterclockwise. If an external signal is used for the speed reference, set it at minimum.
  - b. If a RUN-STOP-JOG switch is used, place it in RUN position. Otherwise, initiate a Run command.
  - c. Turn the MOTOR SPEED potentiometer clockwise or increase the speed reference signal, as applicable. To stop the motor, place the switch in STOP position or initiate a Stop command, as applicable.

If the motor rotates in the wrong direction, turn-off the AC supply to the controller, and then interchange the motor armature leads at the motor connection box or at the controller terminal board.

10. Refer to Section III, “Operation” for operating instructions.

Blank Page

## SECTION III

### OPERATION

#### POWER ON/OFF

To energize the drive, turn-on the AC supply voltage to the controller. When this occurs, the motor shunt field energizes with rated field voltage, and potentially hazardous voltage is present at the motor armature terminals. **These voltages can cause electric shock resulting in personal injury or loss of life.**

If the AC supply is interrupted, and the controller is not set up for line starting, the motor will not restart when the AC supply is restored until the controller is reset by initiating a Stop command and then a Start command. If the controller is set up for line starting, and the AC supply is interrupted, the motor will restart when the AC supply is restored, provided the external AC line contactor is pulled in.

#### RUN

If a RUN-STOP-JOG switch is used, place the switch in RUN position. Otherwise, initiate a Run command. A Run command will accelerate the motor to the setting of the MOTOR SPEED potentiometer or external speed reference signal, as applicable. The rate of acceleration is preset by the ACCEL potentiometer on the controller control board.

#### STOP

If a RUN-STOP-JOG switch is used, place the switch in STOP position. Otherwise, initiate a Stop command. A Stop command will stop the motor at a rate proportional to the stopping rate of the motor load.

If the controller has dynamic braking, the motor stopping time will be reduced. Dynamic braking provides exponential rate braking of the motor armature, which occurs when the circuit is opened between the controller and the motor armature, and one or more resistors connect across the motor armature.

The dynamic braking resistors provide initial braking torque and stops per minute as shown in Table 5.

#### CONTROLLED STOP

Controlled stop is designed to be used with pushbutton (momentary) control, and should always include an emergency stop (coast) pushbutton to guarantee removal of the +24V control voltage from the enable input (TB2:8). When a controlled stop is initiated by momentarily applying +24V to TB2:12 input, the drive will decelerate the motor from set speed to zero speed at the Decel pot setting rate, and then drop out run relay K0 at zero speed ( $\approx 2\%$  or less), determined by armature voltage. Note that if an overhauling load continues to rotate the motor above  $\approx 2\%$  speed, the zero speed detection circuit will not drop out K0.

#### ZERO SPEED DETECTION

The zero speed detection circuit used for controlled stop is also buffered and brought out to TB2:13 for use as an active low Zero Speed Output function ( $\approx 2\%$  or less). The output is rated at 60V and 50ma @100°C, sufficient for switching 24Vdc loads (although the drive +24V power supply cannot supply this much current; it must be customer supplied).



**TABLE 5. DYNAMIC BRAKING CHARACTERISTICS<sup>a</sup>**

COMPONENT	MODEL	RATED VOLTAGE	RATED HORSEPOWER								
			1/6	1/4	1/3	1/2	3/4	1	1-1/2	2	3
BRAKING TORQUE (%)	2611 2615	115V	180	129	103	66	44	34	NA	NA	NA
		230V	NA	NA	400	278	190	130	88	62	NA
	2602 2612	115V	300	215	170	110	75	60	NA	NA	NA
		230V	NA	NA	NA	400	320	220	145	105	85
STOPS PER MINUTE	2611 2615	115V	15	12	11	8	6	2	NA	NA	NA
		230V	NA	NA	12	8	6	1	1	1	NA
	2601 2612	115V	9	6	5	5	4	4	NA	NA	NA
		230V	NA	NA	NA	5	4	4	3	3	2

- a. HIGH INERTIA LOADS MAY EXTEND BRAKING TIME AND CAUSE THE WATTAGE RATING OF THE DYNAMIC BRAKING RESISTORS TO BE EXCEEDED.

An antiplug feature is included with optional Armature Contactor Reversing With Dynamic Braking (Option 1004). This feature prevents restarting the motor before the motor has braked to a stop.

**SPEED CONTROL**

Motor speed is directly proportional to the setting of the MOTOR SPEED potentiometer or the magnitude of an external speed reference signal, as applicable. This potentiometer or the speed reference signal may be adjusted while the motor is running or may be preset before the motor is started.

The rates of acceleration and deceleration are preset by the ACCEL and DECEL potentiometers, respectively, located on the controller control board.

Maximum speed and minimum speed are preset by the MAX SPD and MIN SPD potentiometers, respectively, located on the control board.

**TORQUE CONTROL**

Motor torque is directly proportional to the setting of the CURRENT LIMIT potentiometer or the magnitude of an external torque reference signal, as selected by dip switch SW3, position 3. This potentiometer or the current reference signal may be adjusted while the motor is running or may be preset before the motor is started. Note that if the process demands less torque than the torque reference is commanding, motor speed will continue to increase up to maximum speed.

**JOG**

If a RUN-STOP-JOG switch is used, place the switch in JOG position. Otherwise initiate a Jog command. Jog is momentary, causing motor rotation only while the switch is held in JOG position or while a Jog command is active. Release the switch to stop the motor.

Normally, jog speed is directly proportional to the setting of the MOTOR SPEED potentiometer. If a separate JOG SPEED potentiometer is used, jog speed will be directly proportional to the setting of the JOG SPEED potentiometer.

**REVERSE**

To reverse motor rotation on controllers with reversing capabilities, initiate a Stop function and then initiate a reversing command. The motor will then accelerate to the setting of the MOTOR SPEED potentiometer or external speed reference signal, as applicable. Forward and reverse speed ranges are identical.

If a FWD-REV switch is used, it must have a center position interlock, which requires a momentary relaxation of pressure before the opposite position can be engaged. The center position causes a Stop command and allows time for the motor to stop before a Reverse command is initiated. If a Reverse command is initiated while the motor is rotating, motor and controller damage may occur.

If Option 1004 (Armature Contactor Reversing With Dynamic Braking) is installed, an antiplug feature prevents reversing the motor before the motor has stopped.

**LOAD MONITOR**

UL approved as a motor protection device. The threshold for inverse timed overload will not exceed 120% of rated current and will shut down the drive (drop out K0) in about 60 seconds at 150% load current. The drive may be reset by cycling the enable line, or cycling input line power. Note that the timing capacitor is not reset by this, and that if the drive is immediately restarted into an overload, it will not take the full time to trip.

**CURRENT LOOP TRANSDUCERS**

Several onboard features allow easy interfacing to 4-20mA type transducers as well as other current ranges with appropriate external burden resistors. When SW3 position 2 is closed, an internal 249 $\Omega$  resistor converts 4-20mA to a 1-5V input, and SW3 position 4 in the closed position converts the Min Speed Potentiometer to an Input Offset Potentiometer that allows precise nulling of the zero speed point.

**ARMATURE VOLTAGE AND CURRENT OUTPUTS**

In DC motors, armature voltage and armature current correspond to motor speed and motor load respectively. The drive armature voltage and current feedback signals are isolated, scaled, filtered, and buffered for use as output signals to other customer equipment such as follower and ratio applications or driving indicating meters, etc.

Armature voltage is converted to a 0 to 10Vdc (@2ma) output at TB2:17 and to a general purpose two-wire 4 to 20ma at TB2:15 and 16.

Armature current is converted to a 0 to 10Vdc (@2ma) output at TB2:21 and to a general purpose two-wire 4 to 20ma at TB2:19 and 20.

Note that diode arrays make the outputs insensitive to the external power supply polarity. The 4 to 20ma outputs must be external loop powered ( $\approx$ 8min to 36Vmax).

**SPEED REGULATOR INPUT**

The internal speed regulator input node is brought out to TB2:14 for typical use as an input from an external PID process controller. This input bypasses the accel/decel ramps to provide quicker response than using the standard speed reference input.

**INOPERATIVE MOTOR**

If the motor stops and/or won't start, turn-off the AC supply to the controller, remove the controller cover (if used), and check the AC line fuse on the controller control board. For the location of the fuse, see Figure 23, page 37. If the fuse is blown, refer to the Troubleshooting Table (Table 6).

Blank Page

## SECTION IV

### MAINTENANCE AND REPAIR

#### GENERAL

1. Keep the controller dry and free of dust, dirt, and debris. No parts require periodic replacement.
2. Periodically turn-off the AC line supply to the controller and check all wire terminations to be sure they are tight.
3. Visually check components for damage due to overheating or breakage. All damaged and/or faulty components must be replaced for satisfactory operation.
4. Maintain the motor according to maintenance instructions supplied by the motor manufacturer.

#### ADJUSTMENT INSTRUCTIONS

##### **ACCELERATION**

1. Set the MOTOR SPEED potentiometer at 100% or the external speed reference signal at maximum, as applicable.
2. Initiate a Run command and observe the time required for the motor to reach maximum speed.
3. Adjust the ACCEL potentiometer for the desired rate. Full counter clockwise rotation is the fastest acceleration (0.1 second), and full clockwise rotation is the slowest acceleration (30 seconds).

##### **DECELERATION**

1. With the motor running at maximum speed, quickly reset the MOTOR SPEED potentiometer to zero, or quickly decrease the speed reference signal to minimum, as applicable, and observe the time required for the motor to reach minimum speed.
2. Adjust the DECEL potentiometer for the desired rate. Full counter clockwise rotation is the fastest deceleration (0.1 second), and full clockwise rotation is the slowest deceleration (30 seconds).

##### **IR COMPENSATION**

IR compensation is used only for armature feedback. The IR/COMP potentiometer is factory set at zero (full counterclockwise rotation) for satisfactory operation with most motors. If improved speed regulation is desired, readjust IR compensation as follows:

1. If the motor is shunt-wound, run it at rated base speed. If the motor is a permanent-magnet type, run it at about 1/3 speed.
2. Turn the IR/COMP potentiometer clockwise *slowly* until motor speed becomes unstable. Then turn the potentiometer counterclockwise until motor speed stabilizes.

##### **MAXIMUM SPEED**

The MAX SPD potentiometer is factory set to provide 90 VDC armature voltage with a 115 VAC line, or 180 VDC armature voltage with a 230 VAC line.

To readjust maximum speed, run the motor at maximum speed and adjust the MAX SPD potentiometer for the desired maximum speed.

NOTE: If the MAX SPD potentiometer is turned too far counterclockwise, speed instability may occur.

## Beta Plus / VE Plus

### MINIMUM SPEED

1. Turn the MIN SPD potentiometer fully counterclockwise (0%) for zero speed.
2. Set the MOTOR SPEED potentiometer at 0% or the external speed reference signal at minimum, as applicable.
3. Initiate a Run command and adjust the MIN SPD potentiometer for the desired minimum speed (adjustable from 0 to 40% of motor base speed).

### CURRENT LIMIT

1. Turn the CUR LMT potentiometer fully clockwise (100%) to limit motor armature current at 150% of rated.
2. Turn the CUR LMT potentiometer counterclockwise to reduce maximum motor armature current.

NOTE: An external 5K ohm Current (Torque) Limit potentiometer can be used as shown in Figure 14 on page 14. Dip switch SW3 position 3 must be in the OFF position if an external Current (Torque) Limit potentiometer is desired.

3. The GREEN power on LED indicator will change to RED whenever the controller is limiting (or regulating) current to the motor.

### SPEED AND CURRENT STABILITY

Potentiometer R101 provides gain adjustment to the speed (voltage) amplifier while potentiometer R102 provides gain adjustment to the torque (current) amplifier. An increase in gain (clockwise) speeds up response, although excessive gain may cause unstable speed or vibrations, while a decrease in gain (counterclockwise) will slow down or delay the response, which may be needed for some processes. Best response for a given process can be achieved while monitoring the armature voltage and current output signals at TB2 17 and 21 respectively with an oscilloscope and making adjustments to minimize overshoot and undershoot while commanding speed or torque changes.

### TACHOMETER FEEDBACK SETUP

1. Before connecting or configuring tachometer feedback, follow the instructions to install and perform initial startup, then run drive with maximum input speed reference and adjust the MAX SPEED potentiometer (R8b) for the desired maximum motor speed. Note that for best performance, this should be within +/-20% of the motor nameplate maximum speed or stability problems may occur.
2. Connect the tachometer wires to TB2:7 and 5 (polarity insensitive) and move the one piece jumper on J6, J7 and J8 from the ARM position to the TACH position. (Figure 23 on page 37)
3. Select the tachometer voltage scaling at max speed by dip switch SW3:1 as follows:

TACH VOLTAGE	SW3:1
8Vdc - 30Vdc	ON
31Vdc - 175 Vdc	OFF

4. Adjust the IR/TACH MAX SPEED potentiometer fully clockwise, this will provide minimum speed with tach feedback.
5. Run the motor with maximum speed reference and start adjusting the IR/TACH MAX SPEED potentiometer counterclockwise until motor speed increases to the desired maximum speed with tach feedback. Note that if the tachometer signal is lost, the drive will automatically revert back to armature feedback.

**TROUBLESHOOTING****TABLE 6. TROUBLESHOOTING**

<b>INDICATION</b>	<b>POSSIBLE CAUSE</b>	<b>CORRECTIVE ACTION</b>
1. Motor won't start (See "Inoperative Motor," page 21)	AC line open	Be sure rated AC line voltage is applied to the controller.
	Operator controls inoperative or connected incorrectly	Repair accordingly.
	Open circuit between Connectors E1 and E2	A wire jumper <b>or</b> switch must connect E1 to E2.
	Controller not reset	Initiate a Stop command and then a Start command.
	Line Voltage Selection Jumper J1 in wrong position	See Step 5 on page 5 under, "Installing The Controller."
	Controller not enabled	Be sure +24 VDC is applied to Terminal TB2 8.
	Loss of speed reference signal	Check for 0 - 10 VDC speed reference signal.
	Controller not adjusted correctly	Turn the ACCEL and CUR LMT potentiometers fully counterclockwise (100%).
	Open shunt field winding or wiring to the motor shunt field, causing loss of torque <sup>a</sup>	Check the motor shunt field and associated circuitry for a loose connection or a broken wire. Repair accordingly.
	Motor failure	Repair or replace the motor.
Control board failure	Replace the control board.	
2. Controller line fuse blows when AC line power is applied to the controller	Wiring faulty or incorrect	Check all external wiring terminating in the controller. Correct accordingly.
	Circuit, component, or wiring grounded	Remove ground fault.
	SCR1, SCR2, SCR3 or SCR4 shorted	Replace shorted SCR's or the control board.
	Bridge Diode D1b shorted	Replace shorted diode or the control board.
	Varistor RV1 shorted	Replace RV1 or the control board.
	Shunt Field Diode D39, D40, D41, or D42 shorted <sup>a</sup>	Replace shorted diode or the control board.
	Motor shunt field shorted or grounded <sup>a</sup>	Repair or replace the motor.
	Control board failure	Replace the control board.
<b>Cont'd on next page</b>		

**TABLE 6. TROUBLESHOOTING**

<b>INDICATION</b>	<b>POSSIBLE CAUSE</b>	<b>CORRECTIVE ACTION</b>
3. Controller line fuse blows when a Start command is initiated	One or more SCR's or Diode D1b shorted	Replace shorted devices or the control board.
	Motor shorted or grounded	Repair or replace the motor.
	Control board failure causing SCR's to turn-on fully	Replace the control board.
4. Controller line fuse blows while the motor is running	Motor overloaded	Check shunt field current. <sup>a</sup> Low shunt field current causes excessive armature current. If field current is adequate, check for a mechanical overload. If the unloaded motor shaft does not rotate freely, check motor bearings. Also check for a shorted motor armature. Motor overload can also be caused by incorrect gear ratio. Correct accordingly.
	Loose or corroded connection. Wiring faulty, incorrect, or grounded	Check all terminals, connections, and wiring between the line, controller, and motor.
	Motor shorted or grounded	Repair or replace the motor.
	One or more SCR's or Diode D1b breaking down (shorting intermittently)	Replace faulty devices or the control board.
	Control board failure causing SCR false firing or misfiring	Replace the control board.
5. Minimum speed excessive	Minimum speed not adjusted correctly	Turn the MIN SPD potentiometer counter clockwise.
	Motor armature grounded	Correct ground fault.
	Control board failure	Replace the control board.
6. Maximum speed excessive	Maximum speed set too high	Turn the MAX SPD potentiometer counter clockwise.
	Controller not calibrated correctly	Refer to Steps 4 and 5 on page 5.
	Open shunt field winding or wiring to the motor shunt field <sup>a</sup>	Check the motor shunt field and associated circuitry for a loose connection or a broken wire. Repair accordingly.
	Motor field demagnetized <sup>b</sup>	Replace the motor.
<b>Cont'd on next page</b>		

**TABLE 6. TROUBLESHOOTING**

<b>INDICATION</b>	<b>POSSIBLE CAUSE</b>	<b>CORRECTIVE ACTION</b>
7. Motor won't reach top speed	Low line voltage	Check for rated line voltage, $\pm 10\%$ , on the controller line terminals.
	Motor overloaded	Check shunt field current. <sup>a</sup> Low shunt field current causes excessive armature current. If field current is adequate, check for a mechanical overload. If the unloaded motor shaft does not rotate freely, check motor bearings. Also check for a shorted motor armature. Motor overload can also be caused by incorrect gear ratio. Correct accordingly.
	Maximum speed set too low	Turn the MAX SPD potentiometer clockwise.
	Current limit set too low	Turn the CUR LMT potentiometer clockwise.
	Current scaling jumper J4 in wrong position	See Step 4 and Table 2 on page 5.
	Motor field demagnetized <sup>b</sup>	Replace the motor.
8. Unstable speed	Control board failure	Replace the control board.
	AC line voltage fluctuating	Observe line voltage with a voltmeter or oscilloscope. If fluctuations occur, correct condition accordingly.
	Loose or corroded connection. Wiring faulty, incorrect, or grounded	Check all terminals, connections, and wiring between the line, operator controls, controller, and motor.
	Oscillating load connected to the motor	Stabilize the load. Turning the IR/TACH potentiometer counterclockwise may minimize oscillations.
	Voltage Selection Jumpers J1, J2 or J3 in wrong position	See Step 5 on page 5 under, "Installing The Controller."
	IR compensation not adjusted correctly	See the IR Compensation adjustment instructions on page 23.
	Maximum speed not adjusted correctly	See the Maximum Speed adjustment instructions on page 23.
	Motor faulty	Check motor brushes. Replace if needed. Repair or replace the motor.
Tachometer generator or coupling faulty (if used)	Repair accordingly.	
<b>Cont'd on next page</b>		



**TABLE 6. TROUBLESHOOTING**

INDICATION	POSSIBLE CAUSE	CORRECTIVE ACTION
9. Line and motor armature current excessive	Motor overloaded	Check shunt field current. <sup>a</sup> Low shunt field current causes excessive armature current. If field current is adequate, check for a mechanical overload. If the unloaded motor shaft does not rotate freely, check motor bearings. Also check for a shorted motor armature. Motor overload can also be caused by incorrect gear ratio. Correct accordingly.
10. Shunt field current <sup>a</sup> too low	Open shunt field winding or wiring to the motor shunt field	Check the motor shunt field and associated circuitry for a loose connection or a broken wire. Repair accordingly.
	Shunt field connected for incorrect voltage	Check motor rating and refer to Table 12 on page 34.
	Diode D39, D40, D41, or D42 failure	Replace faulty diode or the control board.
11. Shunt field current <sup>a</sup> too high	Shunt field connected for incorrect voltage	Check motor rating and refer to Table 12 on page 34.
	Shunt field windings shorted	Measure the shunt field resistance and compare with the motor rating. Repair or replace the motor.
12. Motor thermal guard tripped (if used)	Ventilation insufficient	Remove dirt, dust, and debris from the motor intake and exhaust screens.
	Excessive motor load at low speed	Reduce the load or increase the speed.
	Line and motor armature current excessive	See Indication 9.
	Motor overheating from friction	Check for misalignment. Realign the motor.
	Shorted motor windings or faulty bearings	Repair or replace the motor.

a. Does not apply to permanent-magnet motors.

b. Does not apply to shunt-wound motors.

**SECTION V****PARTS LIST****TABLE 7. Parts List, Series Beta Plus / VE Plus Controllers**

<b>PART</b>	<b>RATING</b>	<b>PART NUMBER</b>	
		<b>MODEL RBS2 RBS2C</b>	<b>MODEL VES3 RBS3</b>
Control Board	NA	89520	89521
Diode D1b	15A, 600V	64989	NA
	24A, 600V	NA	64990
Fuse, Line, F1	30A, 600V (ATM-30)	64991	94991
SCR1, SCR2, SCR3, SCR4	15A, 600V	64993	NA
	55A, 800V	NA	64994

Blank Page

## SECTION VI

**RATINGS AND SPECIFICATIONS****RATINGS**

1. Duty ..... Continuous
2. Horsepower Range ..... 1/6 - 3 HP (See Table 1, Page 2)
3. Line Fuse Interrupting Capacity ..... 100,000 Amperes
4. Line Power ..... 115V Or 230V, Single-Phase, 50 Or 60 Hz
5. Motor Speed Potentiometer ..... 5K Ohms, 1/2W
6. Overload Capacity, Armature Circuit ..... 150% For 1 Minute
7. Timed Overload Threshold ..... 120%
8. Service Factor ..... 1.0

**TABLE 8. TYPICAL APPLICATION DATA**

COMPONENT			RATINGS								
RATED HORSEPOWER (HP)			1/6	1/4	1/3	1/2	3/4	1	1-1/2	2	3
RATED KILOWATTS (kW)			0.124	0.187	0.249	0.373	0.560	0.746	1.120	1.492	2.238
1-PHASE AC INPUT (FULL-LOAD)	Line Amps	115V Unit	3.9	5.0	6.0	8.7	12.4	15.8	NA	NA	NA
		230V Unit	NA	NA	NA	4.2	5.9	8.8	12.6	15.8	22.0
	KVA	0.48	0.58	0.71	1.00	1.40	2.00	3.00	4.00	5.00	
DC OUTPUT (FULL-LOAD)	Motor Armature Amps	90V	2.0	2.8	3.5	5.4	8.1	10.5	NA	NA	NA
		180V	NA	NA	NA	2.6	3.8	5.5	8.2	11.6	15.1
	Motor Field Amps (Maximum)	Model RBS2 RBS2C	1.0	1.0	1.0	1.0	1.0	1.0	1.0	1.0	NA
		Model VES3 RBS3	1.5	1.5	1.5	1.5	1.5	1.5	1.5	1.5	1.5
FULL-LOAD TORQUE (lb-ft) with 1750 RPM Base Speed Motors			0.5	0.75	1.0	1.5	2.2	3.0	4.5	6.0	9.0
MINIMUM TRANSFORMER KVA FOR VOLTAGE MATCHING OR ISOLATION			0.5	0.75	0.75	1.0	1.5	2.0	3.0	5.0	7.5

**TABLE 9. OPERATING VOLTAGES AND SIGNALS**

POWER SOURCE (Single-phase)	OUTPUT VDC		SPEED REFERENCE SIGNAL	MAGNETIC CONTROL VOLTAGE
	Armature	Field		
115V, 50 or 60 Hz	0 - 90	50/100	0 -5 Vdc 0 - 10 Vdc 4 - 20Ma	24 VDC
230V, 50 or 60 Hz	0 - 180	100/200		

**TABLE 10. CONTROLLER WEIGHTS**

CONTROLLER MODEL	WEIGHT - LBS (KG)	
	1/6 - 2	3
Rated Horsepower (HP)		
VES3	7.70 (3.50)	
VES3M, VES3U	8.50 (3.86)	
VES3B, VES3S	11.60 (5.26)	
VES3UB, VES3US, VES3MB, VES3MR	12.40 (5.62)	
RBS2, RBS3	3.25 (1.47)	
RBS2U, RBS2M, RBS3U, RBS3M	3.80 (1.72)	
RBS2B, RBS2B-WD, RBS2S, RBS2S-WD, RBS2R, RBS2R-WD	5.50 (2.50)	NA
RBS2UB, RBS2US, RBS2MB, RBS2MR, RBS2UB-WD, RBS2US-WD, RBS2MB-WD, RBS2MR-WD	6.05 (2.75)	NA
RBS2C	2.00 (0.91)	
RBS2UC	2.25 (1.02)	

**OPERATING CONDITIONS**

1. Altitude, Standard ..... 1000 Meters (3300 Feet) Maximum<sup>a</sup>
2. Ambient Temperature ..... 0 - 40°C (32°F - 104°F)<sup>b</sup>
3. Line Frequency Variation ..... ± 2 Hz Of Rated
4. Line Voltage Variation ..... ±10% Of Rated
5. Relative Humidity ..... 95% Noncondensing

**PERFORMANCE CHARACTERISTICS**

1. Controlled Speed Range ..... 0 To Motor Base Speed
2. Displacement Power Factor (Rated Speed/Rated Load) ..... 87%
3. Efficiency (Rated Speed/Rated Load)
  - a. Controller Only ..... 98%
  - b. Controller With Motor, Typical ..... 85%
4. Speed Regulation ..... See Table 11
  - a. Controller can be derated by 1% per 100 meters to operate at higher altitudes.
  - b. 55°C (131°F) maximum in enclosed areas where open-chassis controllers are mounted.

Regulation percentages are of motor base speed under steady-state conditions

**TABLE 11. SPEED REGULATION CHARACTERISTICS**

REGULATION METHOD	VARIABLE				
	Load Change (95%)	Line Voltage ( $\pm 10\%$ )	Field Heating (Cold/Normal)	Temperature ( $\pm 10^{\circ}\text{C}$ )	Speed Range
Standard Voltage Feedback with IR Compensation	2%	$\pm 1\%$	5 - 12%	$\pm 2\%$	50:1
Optional Speed (Tach) Feedback	0.5%	$\pm 1\%$	0.2%	$\pm 2\%$	200:1

### ADJUSTMENTS

1. Acceleration, Linear ..... 0.1 - 30 Seconds
2. Deceleration, Linear ..... 0.1 - 30 Seconds
3. IR (Load) Compensation ..... 0 - 10% Boost
4. Jog Speed ..... 0 - 100% of Motor Base Speed
5. Maximum Speed ..... 50% - 100% of Motor Base Speed
6. Minimum Speed ..... 0 - 40% of Motor Base Speed
7. Torque (Current) Limit ..... 0 - 150% of Full-Load Torque

### SPECIFICATIONS

**1. AC LINE PROTECTION** - A 100,000 ampere interrupting capacity AC line fuse provides instantaneous protection from peak loads and fault currents. This line fuse is located inside the controller.

**2. AUXILIARY CONTACT** - A normally-open Form A relay contact, rated .5 ampere @115 VAC and 2A at 30 VDC, is available for external use. The relay energizes when a Run command is initiated, and de-energizes when a Normal Stop command is initiated, the overload monitor trips, or the anti-restart circuit is activated.

**3. FIELD SUPPLY** - A half-wave or full-wave shunt field supply is available as shown in Table 12, page 34.

**TABLE 12. SHUNT FIELD DATA**

CONTROLLER RATING (VAC)	SHUNT FIELD VOLTAGE (VDC)		MOTOR SHUNT FIELD LEAD CONNECTIONS	
	Half-Wave	Full-Wave <sup>a</sup>	F1	F2
115	50		F/2	F—
		100	F+	F—
230	100		F/2	F—
		200	F+	F—

a. Low inductance motors require a full-wave field to prevent speed instability.

**4. MOTOR CONTACTOR** - Controller model numbers with an ‘A’ or ‘B’ suffix, e.g., RBS2U, RBS2M, have a DC magnetic armature contactor, which disconnects both motor armature leads from the controller.

**5. POWER CONVERSION** - The DC power bridge consists of four SCR’s, one freewheeling diode. Each device is rated at least 600 PIV. The controller base forms an integral heat sink, with the power devices electrically isolated from the base.

**6. SELECTABLE CAPABILITIES** - Switches allow the user to select various modes of operation, as follows:

a. **LINE STARTING** - By placing SW3:5 in the OFF position, the anti-restart feature will be disabled, and the controller may be started and stopped with an external AC line contactor. However, a wire jumper must be connected between TB2-8 and TB2-9. If full speed operation is desired, connect another wire jumper between TB2-2 and TB2-3.

b. **TACHOMETER FEEDBACK** - To use tachometer feedback with armature feedback backup, connect the tachometer generator signal to TB2-7 and TB2-5, (polarity insensitive) and select the tachometer generator voltage at maximum speed by using SW3:1 as follows:

**TABLE 13. TACHOMETER FEEDBACK VOLTAGE SELECTION**

TACH VOLTAGE	SW3:1
8Vdc - 30Vdc	ON
31Vdc - 175 Vdc	OFF

c. **TORQUE REGULATOR** - The controller will function as a torque regulator when SW3:3 is OFF. This allows an external potentiometer to set maximum motor torque (0 - 150% of rated).

**7. VOLTAGE TRANSIENT PROTECTION** - A metal oxide suppressor (varistor) across the AC line is combined with RC snubbers across the power bridge to limit potentially damaging high voltage spikes from the AC power source.

**SECTION VII**

**DRAWINGS**



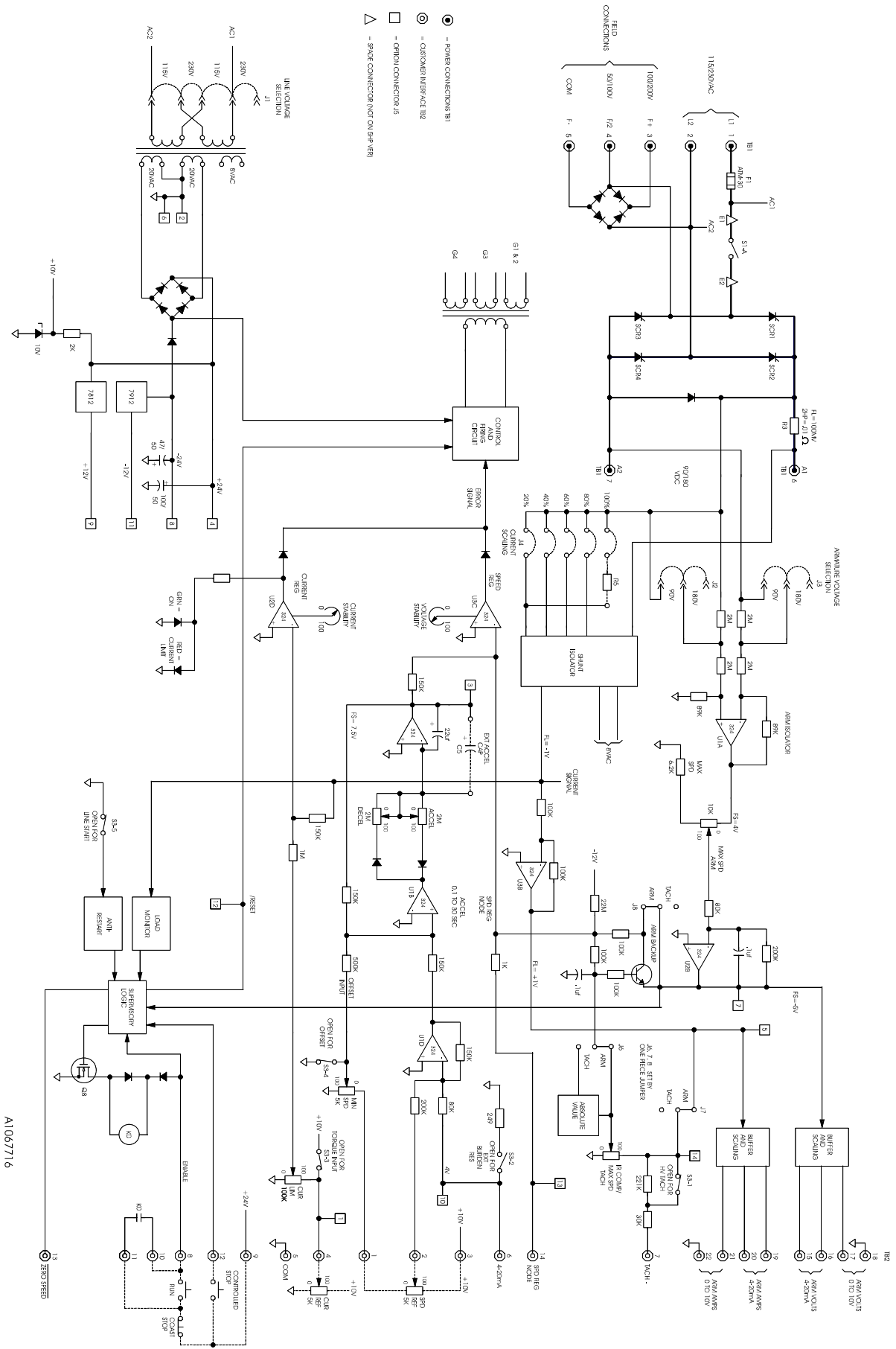

Figure 22. Functional Schematic, Series Beta Plus /

A1067716

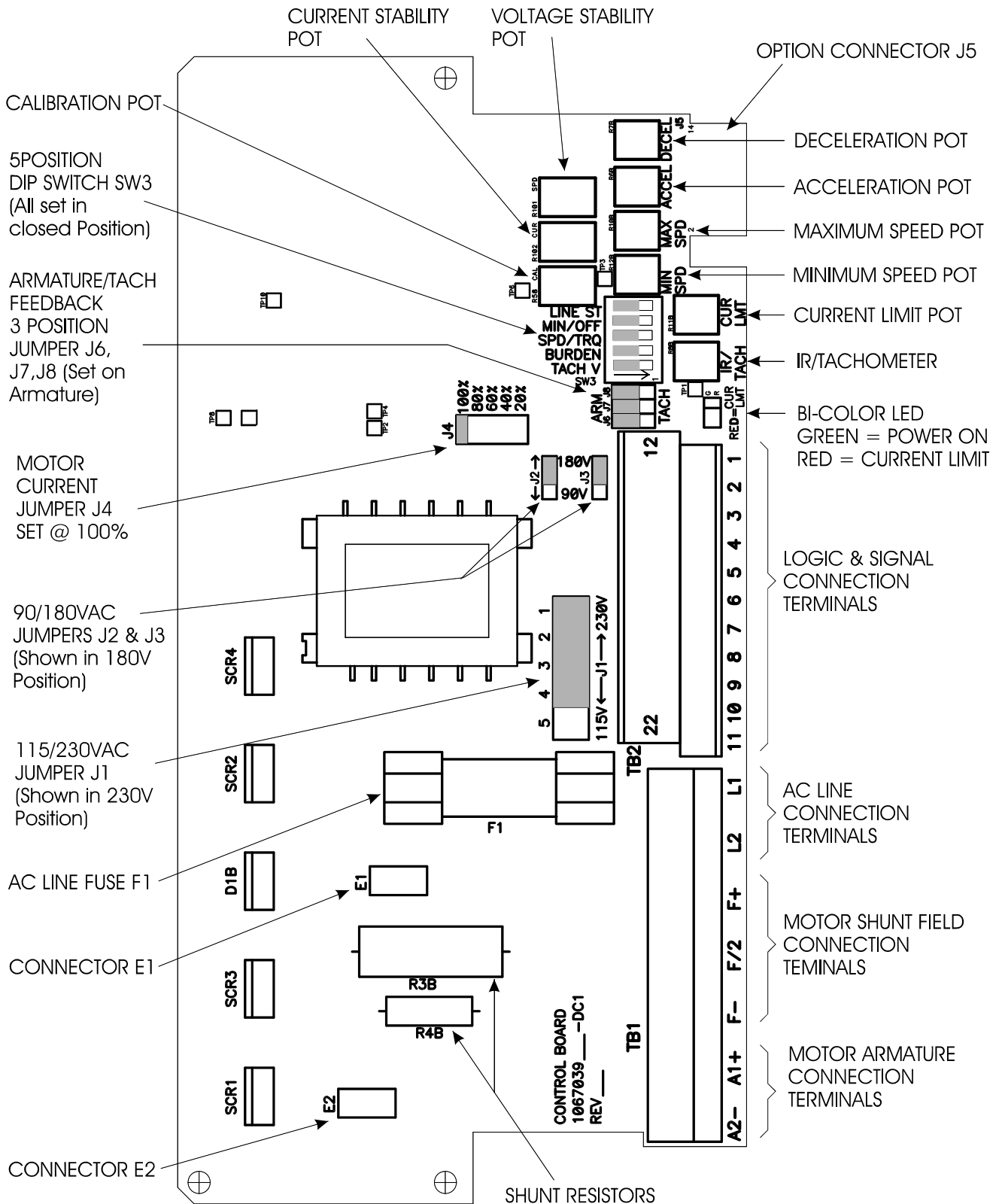

Figure 23. Series Beta Plus / VE Plus Control Board, 1/6 – 3HP

Blank Page

<b>A</b>		<b>F</b>	
<b>AC LINE PROTECTION</b>	33	<b>FIELD SUPPLY</b>	33
AC supply transients	4	full-wave field	5
ACCEL potentiometer	23	fuses	3
<b>ACCELERATION</b>	23	<b>G</b>	
Acceleration, Linear	33	<b><u>GENERAL DESCRIPTION</u></b>	1
<b><u>ADJUSTMENT INSTRUCTIONS</u></b>	23	ground screw	4
Altitude, Standard	32	<b>GROUNDING</b>	4
Ambient Temperature	32	<b>H</b>	
antiplug feature	21	half-wave shunt field voltage	5
anti-restart feature	34	Horsepower Range	31
armature feedback backup	34	<b>I</b>	
<b><u>ARMATURE VOLTAGE AND CURRENT</u></b>		<b><u>INITIAL STARTUP</u></b>	17
<b>OUTPUTS</b>	21	<b><u>INOPERATIVE MOTOR</u></b>	21
<b>ATMOSPHERE</b>	3	<b><u>INSTALLATION GUIDELINES</u></b>	3
<b>AUXILIARY CONTACT</b>	33	<b><u>INSTALLING THE CONTROLLER</u></b>	5
<b>C</b>		<b><u>INTRODUCTION</u></b>	1
circuit breaker	3	IR (Load) Compensation	33
Conduit entry	5	<b>IR COMPENSATION</b>	23
Control wiring	4	IR/COMP potentiometer	23
Controlled Speed Range	32	<b>ISOLATION TRANSFORMER</b>	4
<b><u>CONTROLLED STOP</u></b>	19	<b>J</b>	
<b><u>CONTROLLER CONSTRUCTION</u></b>	3	<b><u>JOG</u></b>	20
<b><u>CONTROLLER MOUNTING</u></b>	3	jog speed	20
<b><u>CONTROLLER MOUNTING DIMENSIONS</u></b>	8	Jog Speed	33
CSA	4	Jumper J4	5
CUR LMT potentiometer	24	Jumpers J1, J2, and J3	5
Current (Torque) Limit potentiometer	24	<b>L</b>	
current (torque) reference pot	6	Line Frequency Variation	32
<b>CURRENT LIMIT</b>	24	line fuse	33
current limiting fuses	3	Line Fuse Interrupting Capacity	31
<b><u>CURRENT LOOP TRANSDUCERS</u></b>	21	Line Power	31
<b>D</b>		line starting	6, 19
DECEL potentiometer	23	<b>LINE STARTING</b>	34
<b>DECELERATION</b>	23	<b>LINE SUPPLY</b>	3
Deceleration, Linear	33	Line Voltage Variation	32
dip switch	6	<b><u>LOAD MONITOR</u></b>	21
disconnect switch	3	Low inductance motors	5
Displacement Power Factor	32	<b>M</b>	
Duty	31	MAX SPD potentiometer	23
dynamic braking	19	Maximum Speed	33
<b>E</b>		<b>MAXIMUM SPEED</b>	23
Efficiency	32		
electrical noise	4		

Beta Plus / VE Plus

MIN SPD potentiometer	24	shielded wire	4
Minimum Speed	33	shipping damage	5
<b>MINIMUM SPEED</b>	24	short-circuit current	3
minimum transformer KVA	3	Signal wiring	4
<b><u>MODEL TYPES</u></b>	2	<b>SPEED AND CURRENT STABILITY</b>	24
<b><u>MOTOR CONTACTOR</u></b>	34	<b><u>SPEED CONTROL</u></b>	20
motor rotation	17	Speed Regulation	32
<b><u>MOTOR SELECTION</u></b>	1	<b><u>SPEED REGULATOR INPUT</u></b>	21
Motor Speed Potentiometer	31	<b><u>STOP</u></b>	19
<b>N</b>		<b>T</b>	
National Electrical Code	1, 4	<b>TACHOMETER FEEDBACK</b>	24, 34
NEMA	1, 3	Timed Overload Threshold	31
<b>O</b>		Torque (Current) Limit	33
Oscillating load	27	<b><u>TORQUE CONTROL</u></b>	20
Overload Capacity	31	<b><u>TORQUE REGULATOR</u></b>	34
<b>P</b>		transformer	3
<b><u>PARTS LIST</u></b>	29	transients	3
power bridge	34	<b><u>TROUBLESHOOTING</u></b>	25
<b>POWER CONVERSION</b>	34	Twisted cable	4
power factor correction capacitors	3	<b>U</b>	
power wiring	4, 5	Underwriters Laboratories	1
<b>R</b>		<b>V</b>	
<b><u>RATINGS AND SPECIFICATIONS</u></b>	31	varistor	3, 34
Relative Humidity	32	vibration	3
<b><u>REVERSE</u></b>	21	<b>VOLTAGE TRANSIENT PROTECTION</b>	34
<b><u>RUN</u></b>	19	<b>W</b>	
<b>S</b>		<b>WIRING PRACTICES</b>	4
<b>SELECTABLE CAPABILITIES</b>	34	<b>Z</b>	
Service Factor	31	<b><u>ZERO SPEED DETECTION</u></b>	19

## Warranty

Boston Gear warrants that products manufactured or sold by it shall be free from defects in material and workmanship. Any products which shall within two (2) years of delivery, be proved to the Company's satisfaction to have been defective at the time of delivery in these respects will be replaced or repaired by the Company at its option. Freight is the responsibility of the customer. The Company's liability under this limited warranty is limited to such replacement or repair and it shall not be held liable in any form of action for direct or consequential damages to property or person. The foregoing limited warranty is expressly made in lieu of all other warranties whatsoever, express, implied and statutory and including without limitation the implied warranties of merchantability and fitness.

No employee, agent, distributor, or other person is authorized to give additional warranties on behalf of Boston Gear, nor to assume for Boston Gear any other liability in connection with any of its products, except an officer of Boston Gear by a signed writing.



**Boston Gear**  
14 Hayward Street ▪ Quincy, MA 02171  
617-328-3300 ▪ Fax: 617-479-6238  
[www.bostongear.com](http://www.bostongear.com)