

Centric Pneumatic Torque Limiting Disconnect Clutch

Installation and Operation

P-3013-BG
Doc. No. 84372
PDC Series



 **Boston**[®]
Gear

An **Altra Industrial Motion** Company

I. Operating Principle

The Boston Gear PDC Series Pneumatic Disconnect Clutch is a ball detent air actuated device. It has been designed to provide accurate and dependable torque overload protection for mechanical power transmission equipment. It has also been designed to provide a remote disconnection of the drive when the air supply is removed. The following diagram demonstrates the engaged and disengaged functions.

The top half of the view shows the unit in an engaged condition, 20 to 80 psi of shop air is forced into the air chamber. That air pressure exerts a force on a hardened thrust plate that pushes against six chrome alloy steel balls. The balls are forced into detent pressure remotely controls precision "in flight" torque adjustment. The machinery can still be in operation when the torque rating is being adjusted. When a torque overload occurs, the housing and rotor rotate independently of each other. The balls roll out of their detents and a limit switch actuating plate moves forward to trip a limit switch and signal a torque overload condition. The drive should be shut down immediately and the source of the overload determined and cleared. To re-engage the clutch, re-apply the air pressure and jog the drive until the clutch engages. The PDC Series is a single position device. The unit will re-engage every 360 degrees in the same location

every time. The bottom half of the view shows the unit in a disengaged condition. When air is disconnected, internal springs push the ball cage away from detent face of the housing. The balls are held captive by the ball cage so they also move away from the detent face. At this point the unit is free to rotate in a disengaged condition. The main components that transmit torque are not in contact with each other.

Important!

If a solenoid valve is used to control the air supply to the clutch, it is imperative that the valve is self exhausting. There must be an open port to the atmosphere when the valve is de-energized. Failure to use a self exhausting valve will cause air pressure to be trapped in the air chamber and the unit will not disengage.

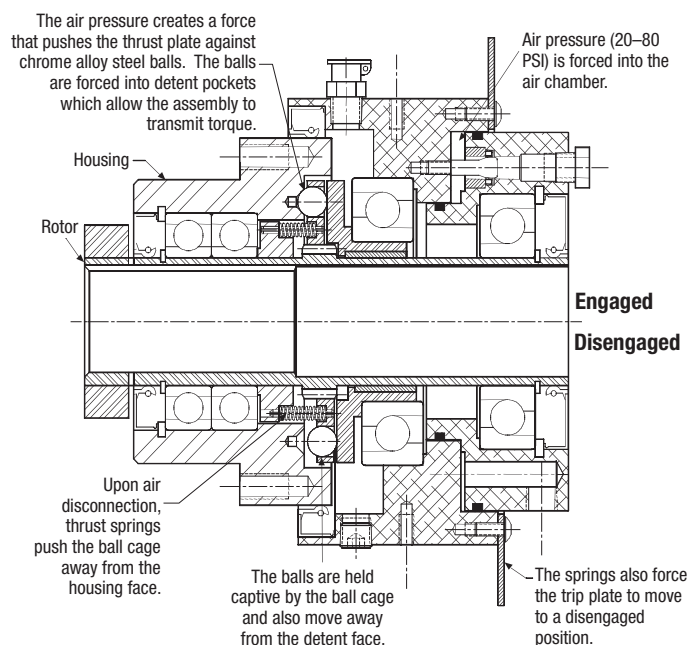

II. Mounting Sprockets or Sheaves

The PDC Series is built with dual radial ball bearings in the housing, therefore no additional bearing support is required for sprocket or sheave mounts. The following figure shows a typical HTD sprocket mounting.

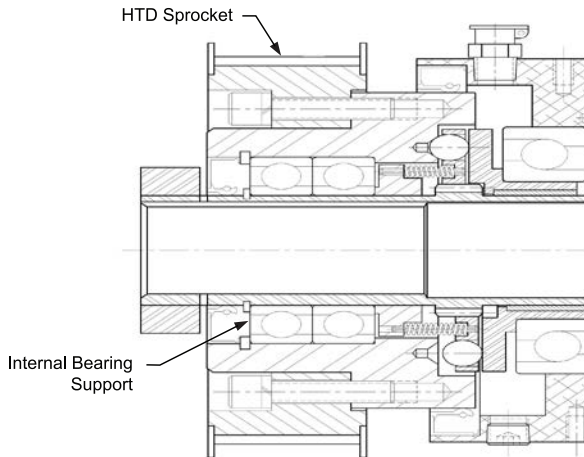

Sprocket Mounting Procedure

- Inspect mating pilot diameters on housing and sprocket for nicks or burrs and remove as required.
- Position sprocket on clutch housing and align mounting holes.
- Attach sprocket to housing with mounting bolts and high collar lock washers. The recommended tightening torque for the mounting bolts on a PDC04 with standard hub is 305 inch-lb. The PDC04 with reduced hub should be tightened to 49 inch-lb.

III. Locating and Mounting Clutch to Shaft

A. Mounting Basic Clutch

- Inspect shaft and key for any nicks or burrs and remove as required.
- Loosen clamp collar on clutch.
- Position shaft key and slide clutch onto shaft.
- Align sprocket mounted to clutch with mating sprocket in the drive train.
- Secure the clutch to the drive shaft by tightening the clamp collar. For the PDC

size 04 the recommended tightening torque for the clamp collar is 110 inch-lb.

B. Connecting the Air Supply

- Stabilize the air cylinder to prevent it from rotating. This can be accomplished by using a 1/8-27 NPT rigid pipe fitting. The pipe fitting can be held captive for the air piston does not move.
- Rotate the air union so that the oil cup is in a vertical position and the air inlet is in the seven o'clock position. Refer to the following figure for proper orientation.
- Attach a flexible air connection to the end of the stabilized pipe fitting.

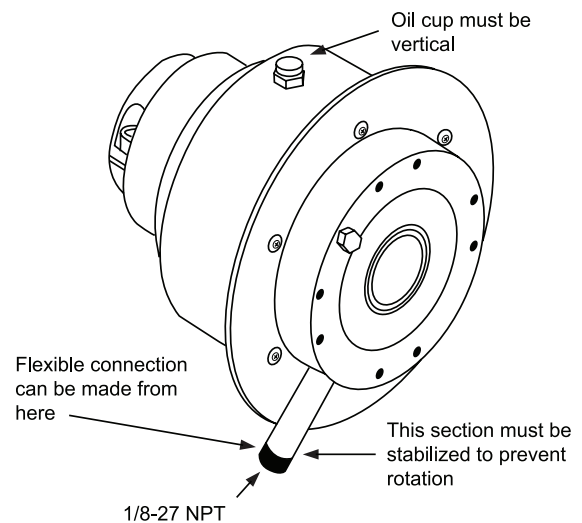

IV. Initial Startup

A. Lubrication

The PDC Series pneumatic disconnect clutch requires oil lubrication and it is not filled at the factory. Therefore it is important that oil is added to the unit prior to startup. Add two fluid ounces of ISO viscosity grade 460 oil to the vertically mounted oil cup. Mobil SHC634 or equivalent is recommended.

B. Air Pressure Setting

Adjust the air pressure to the desired torque setting. Never apply more than 80 psi to the air chamber for damage to the seals

may occur. The following chart will show the appropriate air pressure values for desired torque values.

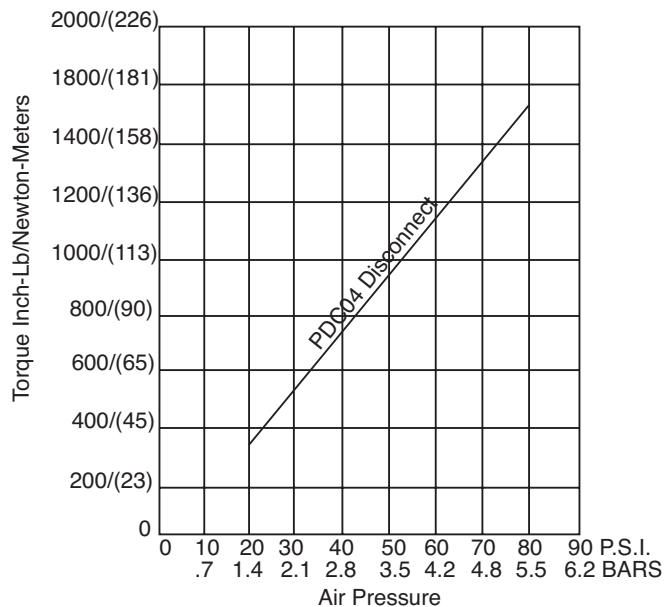

C. Starting the Drive

The PDC Series clutch is a one revolution, single position reset device. There is only one position where the unit will engage. After the initial installation the clutch may not be in an engaged position. Apply the desired air pressure to the clutch and slowly jog the drive around until the clutch re-engages with an audible sound. The trip plate will move .13 inches when the unit re-engages. The clutch and driven machinery are now ready for operation.

V. Limit Switches

It is recommended that a limit switch should be used in conjunction with the PDC Series pneumatic disconnect clutch. It is important that the switch shuts down the drive immediately upon a torque overload condition.

The switch should be able to operate within the disengagement travel of the clutch. Upon an overload, the cylinder of the clutch will move to actuate the limit switch and shut down the drive. An oversized metallic plate provides a means for sensing movement from both ends of the clutch and for the utilization of precision proximity switches.

The limit switch should be wired in its normally closed condition. The switch is used to open the circuit to the motor during a torque overload condition. The switch should be wired in parallel with the JOG button of the motor control. This will permit the drive to be started in the event the PDC Series clutch has stopped with the limit switch circuit in an open state.

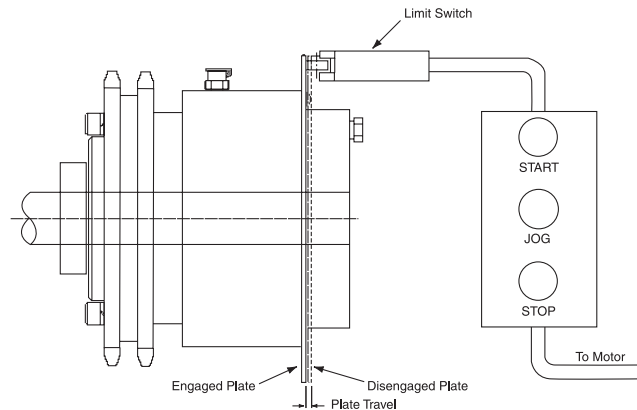

VI. General Maintenance

A. Lubrication

The PDC Series Pneumatic disconnect clutch should be lubricated with an ISO viscosity grade 460 oil. The oil should be drained and refilled every 5,000 hours of operation. There is an oil drain plug located 180 degrees from the oil fill cup. Two fluid ounces of an ISO viscosity grade 460 oil should be used. Mobil SHC634 oil is available in quart containers through Boston Gear as part number 51493.

B. Maintenance and Repair

The PDC Series clutch is constructed of heavy duty materials. Under reasonable conditions the unit will perform trouble free for many hours of operation. In the event that a repair is needed, it is suggested that the unit be sent back to the factory in Charlotte, NC. Call our customer service department at 1-888-999-9860 for a return goods authorization (RGA) number.

Warranty

Boston Gear warrants that products manufactured or sold by it shall be free from defects in material and workmanship. Any products which shall within two (2) years of delivery, be proved to the Company's satisfaction to have been defective at the time of delivery in these respects will be replaced or repaired by the Company at its option. Freight is the responsibility of the customer. The Company's liability under this limited warranty is limited to such replacement or repair and it shall not be held liable in any form of action for direct or consequential damages to property or person. THE FOREGOING LIMITED WARRANTY IS EXPRESSLY MADE IN LIEU OF ALL OTHER WARRANTIES WHATSOEVER, EXPRESS, IMPLIED AND STATUTORY AND INCLUDING WITHOUT LIMITATION THE IMPLIED WARRANTIES OF MERCHANTABILITY AND FITNESS.

No employee, agent, distributor, or other person is authorized to give additional warranties on behalf of Boston Gear, nor to assume for Boston Gear any other liability in connection with any of its products, except an officer of Boston Gear by a signed writing.



www.bostongear.com

701 Carrier Drive
Charlotte, NC 28216
704-588-5610
Fax 704-588-7181

An **Altra** Industrial Motion Company

