

Centrifical Clutch Couplings

Installation and Operation

P-3015-BG
Doc. No. 84371

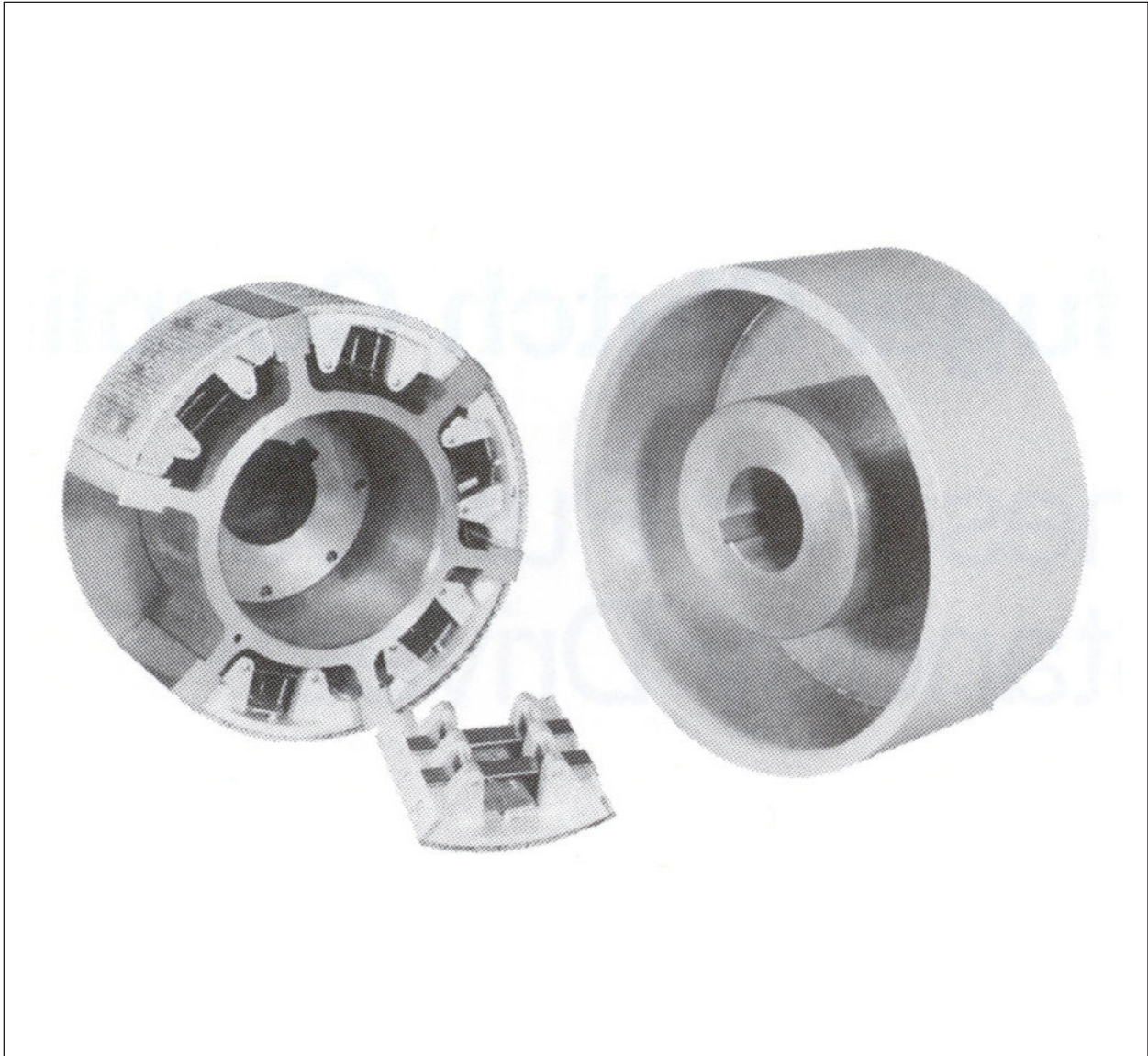

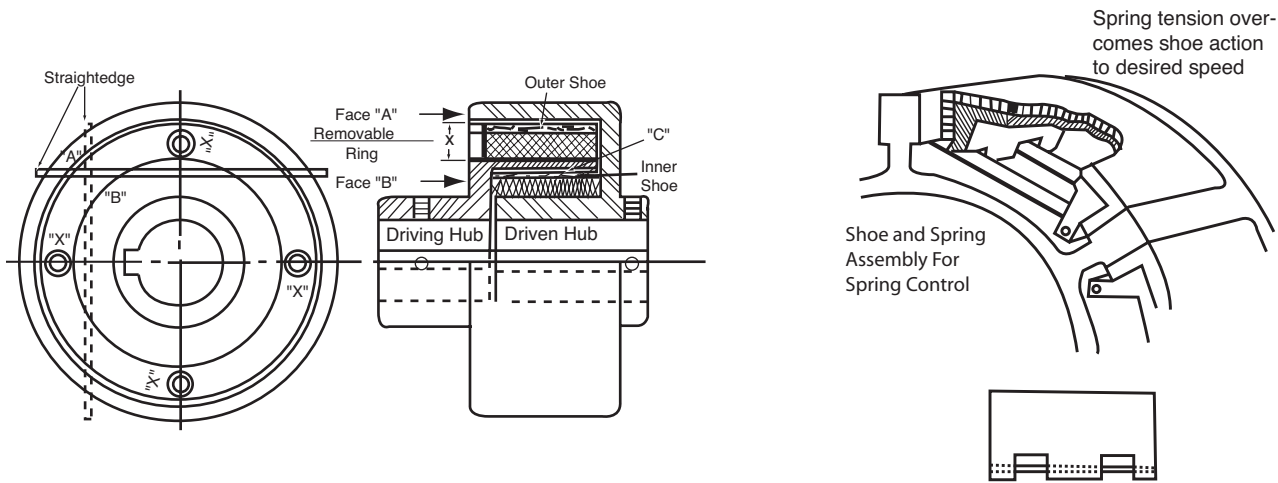

Centric Spring Control Coupling Type A

Cleaning: Before mounting Coupling be sure all parts are washed with kerosene and are free from dirt and grease.

Lubrication: DO NOT lubricate any part of this Coupling.

Alignment: Correct alignment of drive and driven shafts is essential. The frictional lining of the shoes will wear a long time if correctly aligned.

Mounting: Key the drive and driven hubs on their respective shafts, the hub faces being made flush with shaft ends.

Centric Couplings start without shock, therefore, drive or shrink fits are unnecessary. Bring Coupling hubs together until faces "A" and "B" are in the same plane. A straight-edge placed across the faces in two directions gives an accurate test.

Remove ring. Make the distance "X" equal at four points 90 degrees apart using inside caliper to secure accuracy. Dimension "X" should be equal at all points when driving and driven machines are at normal operating temperature (Center line frequently changes due to heat from operation).

Insert outer shoes then replace ring.

Lining: Keep frictional Lining free from oil, grease, and dirt.

Inspection of Shoes: Remove ring and pull out shoes.

Couplings with spring retained shoes have only outer shoes.

Shoe Replacements: When ordering new shoes for this Coupling give the following data:

Size Serial No
HOP R.P.M Idle Speed

It is advisable to always have a spare set of shoes on hand. This will prevent the machine from remaining idle while awaiting delivery of a new set.

Starting: Across-the-line starting is recommended. Motor starts without load, therefore, starting resistors unnecessary. When starting resistors are used, bring to running position as quickly as possible.

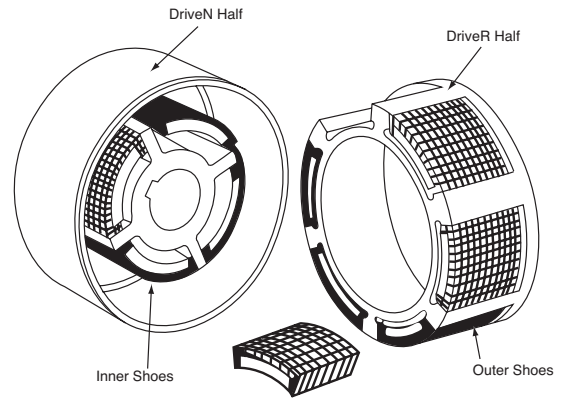
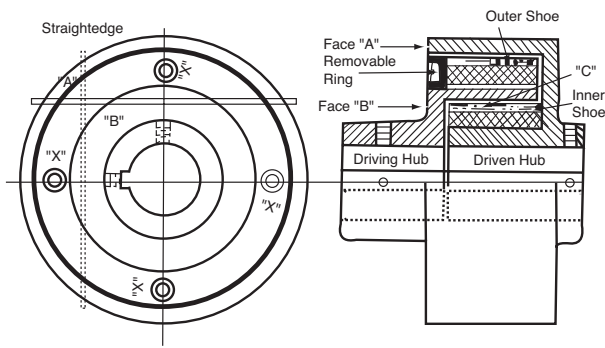

Centric Coupling Type A

Cleaning: Before mounting Coupling be sure all parts are washed with kerosene and are free from dirt and grease.

Lubrication: DO NOT lubricate any part of this Coupling.

Alignment: Correct alignment of drive and driven shafts is essential. The frictional lining of the shoes will wear a long time if correctly aligned.

Mounting: Key the drive and driven hubs on their respective shafts, the hub faces being made flush with shaft ends.

Centric Couplings start without shock, therefore, drive or shrink fits are unnecessary.

Assemble inner shoes in their pockets around the driven hub, holding them in place by tying a light string around the shoes at point "C". Bring driving shaft partly inside of driven hub. Cut string and pull it out from lower opening. Bring Coupling hubs together until faces "A" and "B" are in the same plane. A straight-edge placed across the faces in two directions gives an accurate test.

Remove ring. Make the distance "X" equal at four points 90 degrees apart using inside caliper to secure accuracy. Dimension "X" should be equal at all points when driving and driven machines are at all points when driving and driven machines are at normal operating temperature (Center line frequently changes due to heat from operation).

Insert outer shoes then replace ring.

Lining: Keep frictional Lining free from oil, grease, and dirt.

Inspection Of Shoes: Remove ring and pull out outer shoes. Inner shoes do not need inspection as they are not liable to excessive slippage in case of accidental stoppage of the driven shaft.

Couplings with spring retained shoes have only outer shoes.

Shoe Replacements: When ordering new shoes for this Coupling give the following data:

SizeSerial No.
HOPSpeed

It is advisable to always have a spare set of outside shoes on hand. This will prevent the machine from remaining idle while awaiting delivery of a new set.

Starting: Across-the-line starting is recommended. Motor starts without load, therefore, starting resistors unnecessary. When starting resistors are used, bring to running position as quickly as possible.

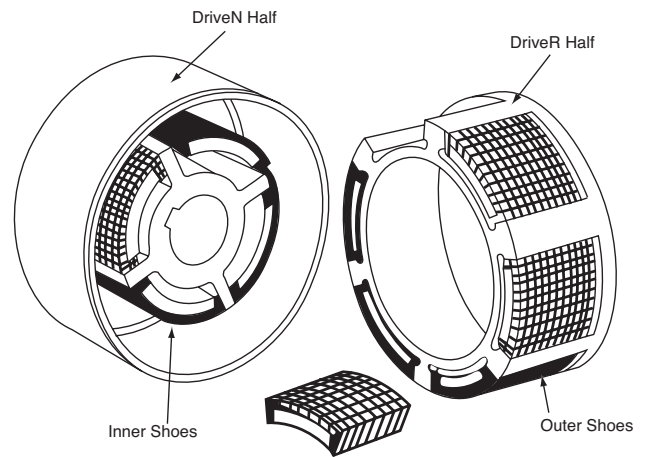
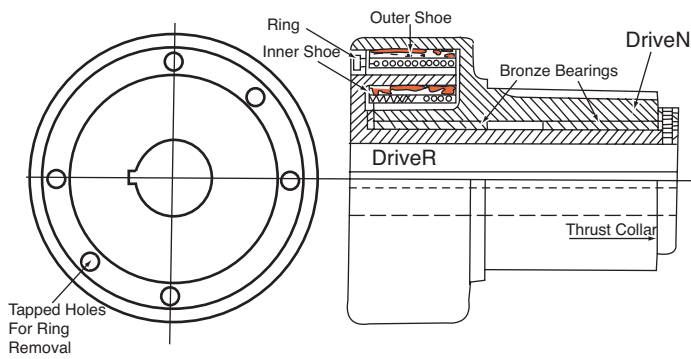

Centric Coupling Type B

Lubrication: DO NOT lubricate any part of this Coupling unless an Alemite or Zirk fitting is provided.

Alignment: Shaft on which Coupling is mounted must be parallel with shaft of driven machine. Drive and driven pulleys, sheaves or sprockets should be aligned perfectly or undue pressure will cause excessive wear on bushing, thrust washer, or collar. Excessive tension requires extra power and causes excessive wear on the oilless bushing. For Vee Belts and Chains follow the maker's instructions for tension.

Mounting: Couplings are shipped assembled as shown. First, fit and key pulley, sheave, or sprocket on driven hub if not an integral part of the Coupling.

For reassembly of Coupling stand the DriveN hub on end, assemble the inner shoes in the pockets, insert the DriveR hub in the hole of the DriveN hub and remove the ring from the DriveR hub. Place the outer shoes in the pockets and replace ring. Turn the assembled Coupling on its side and put on thrust collar. Tapped holes are provided for withdrawing the ring.

Lining: Keep frictional Lining free from oil, grease, and dirt.

Inspection Of Shoes: Remove ring and pull out outer shoes. Inner shoes do not need inspection as they are not liable to excessive slippage in case of accidental stoppage of the driven shaft.

Coupling with spring retained shoes have only outer shoes.

Shoe Replacements: When ordering new shoes for this Coupling give the following data:

Size Serial No.
HP Speed

It is advisable to always have a spare set of outside shoes on hand. This will prevent the machine from remaining idle while awaiting delivery of a new set.

Starting: Across-the-line starting is recommended. Motor starts without load, therefore, starting resistors unnecessary. When starting resistors are used, bring to running position as quickly as possible.

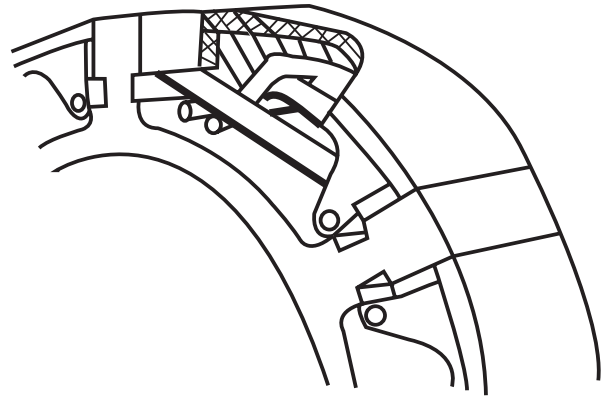
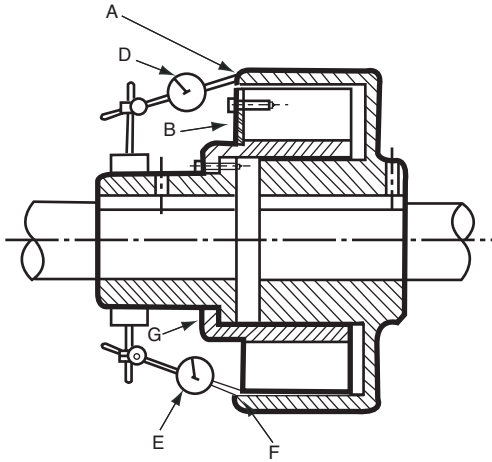

Type AVL Spring Control

Cleaning: Before mounting Coupling be sure all parts are washed with a solvent and are free from dirt and grease.

Mounting: Remove outer shoes and springs and put them aside. Key the driver and driven hubs on their respective shafts, the hub faces being made flush with the shaft ends where possible. Secure set screws to each shaft. Remove the shoe retaining ring and allow to hang loose on the driving hub. Slide the driving half of the clutch inside the driven half until faces "A" and "B" are in the same plane. A straight edge placed across the faces will give a rough check. Align the two shafts checking as outlined under "Alignment." When alignment is completed insert the outer shoes in their pockets and replace the shoe retaining ring.

Alignment: Correct alignment of the driving and driven shafts is essential. The frictional lining of the shoe will wear for a long time if correctly aligned. Check angular alignment of shafts by mounting a magnetic base indicator on the driving hub as shown at "D". Indicate I.D. of driven half at point "F" by rotating the driving hub. All final alignment should be with both the driving and driven components at normal operating temperature.

Vertical Lift Out: Remove cap screws in face "G" and slide out driving spider. Remove shoes and lift either member vertically.

To Replace: Lower vertically lifted unit into original position. Replace inner shoes as above and slide driving spider into position and bolt fast with cap screws in face "G". Align unit as required.

Lubrication: DO NOT lubricate any part of this coupling.

Lining: Keep frictional Lining free from oil, grease, and dirt.

Inspection Of Shoes: Remove ring and pull out shoes.

Couplings with spring retainer shoes have only outer shoes.

Shoe Replacements: When ordering new shoes for this Coupling give the following data:

Size Serial No.
 HP Speed

It is advisable to always have a spare set of outside shoes on hand. This will prevent the machine from remaining idle while awaiting delivery of a new set.

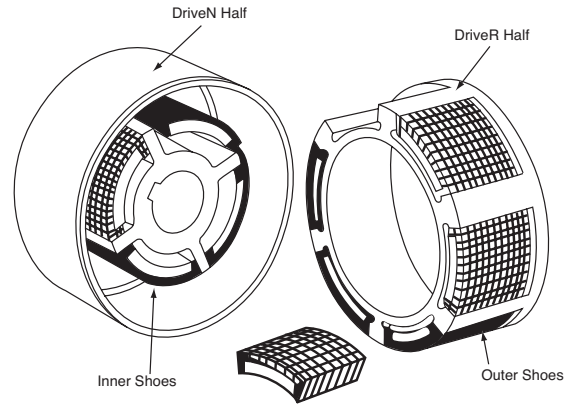
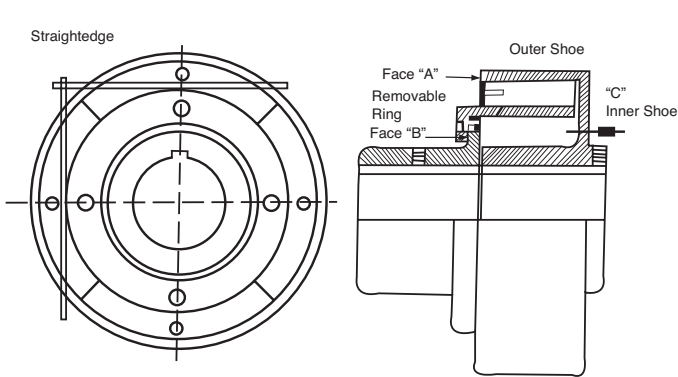

Type AVL Coupling

Cleaning: Before mounting Coupling be sure all parts are washed with kerosene and are free from dirt and grease.

Lubrication: DO NOT lubricate any part of this Coupling.

Alignment: Correct alignment of drive and driven shafts is essential. The frictional lining of the shoes will wear a long time if correctly aligned.

Mounting: Key the drive and driven hubs on their respective shafts, the hub faces being made flush with shaft ends. Assemble inner shoes in their pockets around the driven hub, holding them in place by tying a light string around the shoes at point "C". Bring driving shaft partly inside of driven hub. Cut string and pull it out from lower opening. Bring Coupling hubs together until faces "A" and "B" are in the same plane. A straight-edge placed across the faces in two directions gives an accurate test.

Remove ring. Make the distance "X" equal at four points 90 degrees apart using inside caliper to secure accuracy. Dimension "X" should be equal at all points when driving and driven machines are at normal operating temperature (Center line frequently changes due to heat from operation).

Insert outer shoes then replace ring.

Vertical Lift Out: Remove cap screws in face "E" and slide out driving spider. Remove shoes and lift either member vertically.

To Replace: Lower vertically lifted unit into original position

Replace inner shoes as above and slide driving spider into position and bolt fast with cap screws in face "E". Align unit as indicated under MOUNTING.

Lining: Keep frictional Lining free from oil, grease and dirt.

Inspection Of Shoes: Remove ring and pull out outer shoes. Inner shoes do not need inspection as they are not liable to excessive slippage in case of accidental stoppage of the driven shaft.

Couplings with spring retained shoes have only outer shoes.

Shoe Replacements: When ordering new shoes for this Coupling give the following data:

SizeSerial No.
HPSpeed

It is advisable to always have a spare set of outside shoes on hand. This will prevent the machine from remaining idle

Warranty

Boston Gear warrants that products manufactured or sold by it shall be free from defects in material and workmanship. Any products which shall within two (2) years of delivery, be proved to the Company's satisfaction to have been defective at the time of delivery in these respects will be replaced or repaired by the Company at its option. Freight is the responsibility of the customer. The Company's liability under this limited warranty is limited to such replacement or repair and it shall not be held liable in any form of action for direct or consequential damages to property or person. THE FOREGOING LIMITED WARRANTY IS EXPRESSLY MADE IN LIEU OF ALL OTHER WARRANTIES WHATSOEVER, EXPRESS, IMPLIED AND STATUTORY AND INCLUDING WITHOUT LIMITATION THE IMPLIED WARRANTIES OF MERCHANTABILITY AND FITNESS.

No employee, agent, distributor, or other person is authorized to give additional warranties on behalf of Boston Gear, nor to assume for Boston Gear any other liability in connection with any of its products, except an officer of Boston Gear by a signed writing.



www.bostongear.com

701 Carrier Drive
Charlotte, NC 28216
704-588-5610
Fax 704-588-7181

An **Altra Industrial Motion** Company

