

Boston Gear[®]

Ratiotrol[®]

DC Motor Speed Control

P-3025-BG

Installation and Operation

Doc. No. 60001

DCX[™] Series II
Chassis Models
1/12 - 3 HP

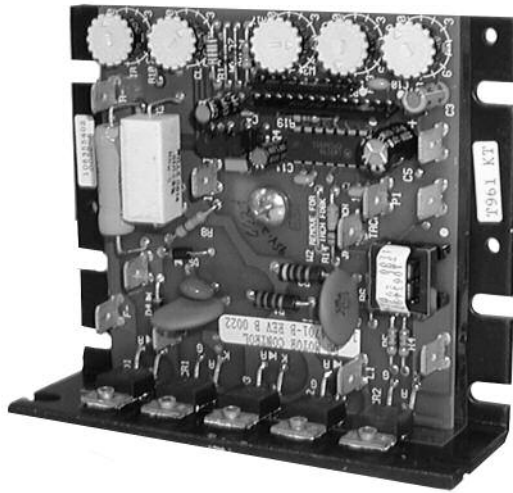

a division of **Altra Industrial Motion**

Contents

I General Information	
Description	2
Ratings	2
Operating Conditions	2
Performance Characteristics	2
Adjustments	2
Safety Warnings	3
II Installation Instructions	
Mounting	4
Wiring Instructions	4
DCX102C Connections	5
DCX202C / DCX302C Connections	5
Initial Start Up	5
Tachometer Feedback	6
III Calibration Procedure	
Safety Precautions	7
Procedure	7
IV Switching Circuits	8-9
V Dimensions	10
VI Options	11

Section I

General Information

Description

Ratiotrol DCX controllers statically convert single-phase AC line power to regulated DC for adjustable speed armature control of shunt-wound and permanent-magnet DC motors.

Ratings

1. Service Factor 1.0
2. Duty Continuous
3. Environment Industrial
4. Overload Capacity 150% for 1 minute

Operating Conditions

1. Line Voltage 115/230VAC \pm 10%
2. Line Frequency 50/60 Hz \pm 2 Hz
3. Ambient Temperature 0°C to 50°C
(32°F to 122°F)
4. Altitude 3300 feet
(1000 meters) maximum
5. Relative Humidity 95% noncondensing,
maximum
6. DC Tachometer Voltage† 35, 50 or 100
VDC/1000 RPM*

* Modifiable for 7 VDC/1000 RPM

† Models DCX202C & DCX302C only

Performance Characteristics

1. Controlled Speed Range . . . 0 to motor base
speed
2. Speed Regulation or Regulation percentages
shown in Table 2 are of motor base speed
under steady-state conditions
3. Efficiency (at maximum speed)
 - a. Controller 99%
 - b. Controller with motor 85

Adjustments

1. Accel/Decel 0.8 - 10 seconds *
2. Maximum Speed (% of full speed) 60 - 100%
3. Current Limit (% full load torque) . . .0 - 150%
4. Minimum Speed (% of full speed) . . .0 - 40%
5. IR Compensation (% of rated load) .0 - 100%

* DCX102C has a fixed accel/decels of 1 second

Table 1 - Ratings

Rated HP	Full Load Torque lb. in.	AC Input Single Phase, 50/60 Hz (Full Load)					DC Output (Full Load)				
		Line Amps					KVA	Motor		Motor	
		DCX102C	DCX202C		DCX302C			Arm.	Amps	Field Amps	
		115 VAC	115 VAC	230 VAC	115 VAC	230 VAC		90 VDC	180 VDC	100 VDC	200 VDC
1/12	3	2.0	2.0		2.0		0.30	0.9		1.0	
1/6	6	3.9	3.9		3.9		0.48	2.0		1.0	
1/4	9	5.0	5.0		5.0		0.58	2.8		1.0	
1/3	12	6.0	6.0		6.0		0.71	3.5		1.0	
1/2	18	8.7	8.7	4.8	8.7	4.8	1.0	5.4	2.7	1.0	1.0
3/4	27		12.4*	5.9	12.4	5.9	1.4	8.1	3.8	1.0	1.0
1	36		15.0*	8.8	15.0	8.8	2.0	10.5	5.5	1.0	1.0
1-1/2	54			12.6*		12.6	3.0		8.2		1.0
2	72			15.8*		15.8	4.0		11.6		1.0
3	108					24.0	6.0		16.0		1.0

* Optional heatsink required

Table 2 - Speed Regulation Characteristics

Regulation Method	Variable				
	Load Change 95%	Line Voltage ±10%	Field Heating Cold/Normal	Temp. ±10°C	Speed Range
Standard Voltage Feedback with IR Compensation	2%	±1%	5-12%	±2%	30:1
Tach* Feedback (Uni-directional models only)	1%	±1%	0.2%	±2%	100:1

* Not available on DCX102C

Safety Warnings

- Controller is not isolated from earth ground. Thus the printed circuit board and its components are at AC line potential and could cause serious injury.
- Follow all local electrical and safety codes, as well as National Electrical Code (NEC) and when applicable, the Occupational Safety and Health Act (OSHA). This device should be installed, adapted and serviced by qualified electrical maintenance personnel familiar with the construction and operation of the equipment and the hazards involved.
- Motor and Controller must be securely and adequately grounded.
- Always disconnect power source before working on or near controller and motor or their lead wires.
- Make sure the power source conforms to the requirement of your equipment.
- Do not operate controller near high capacitive discharge electrical equipment (i.e. electrical welders).
- When cleaning electrical or electronic equipment, always use an approved cleaning agent such as dry cleaning solvent.
- Do not operate controller in an explosive atmosphere.
- Use insulated tools (non-metallic) when making running adjustments. Be careful not to touch any components except the adjusting trimpots.
- SCR CONTROLLERS ARE NOT FAIL SAFE. IF AN SCR SHORTS, CONTROL BOARD FAILS OR GROUND FAULT OCCURS, MOTOR MAY RUN AT FULL SPEED.

Section II

Installation Instructions

Mounting:

Do not locate DCX Series Chassis Controller where temperature, moisture, oil solvents or dust can affect controller operation or damage its components. When mounting in an enclosure, leave room to allow access to chassis after installation for wiring, un-mounting or other related reasons. See Page 10 for mounting dimensions.

▲CAUTION Do not mount chassis controller where ambient temperature is outside the range of 0°C (32°F) to +50°C (122°).

DCX202C Chassis must be mounted on auxiliary Heatsink for 3/4-1 HP at 115 VAC and 1-1/2 - 2 HP at 230 VAC.

BASE HEATSINK	DCX-HTSK	67106
RADIAL HEATSINK	DCX-RHTSK	67098

DCX202C Ratings with Heatsinks

Voltage Input	Max. HP	Using Heatsink
115 VAC	3/4	DCX-HTSK
	1	DCX-RHTSK
230 VAC	1-1/2	DCX-HTSK
	2	DCX-RHTSK

Shock and excessive vibration are detrimental to controller performance and life. Vibration can cause general deterioration of connections and component damage. Therefore, shock mount the controller if it is subjected to excessive vibration.

Wiring Instructions

Refer to the data label on the controller to be sure the input voltage and frequency to the controller comply with its rating. Follow all local electrical and safety codes, as well as National Electrical Code (NEC) and when applicable, the Occupational Safety and Health Act (OSHA). This device should be installed, adapted and serviced by qualified electrical maintenance personnel familiar with the construction and operation of the equipment and the hazards involved. The following procedure should be followed when

wiring the controller. Figures 1 and 2 on Page 5 are using the 1/4 inch female push-on connectors. (provided.)

1. Place the controller on a feeder line separate from that supplying large inductive loads.
2. If the input power to the controller comes directly from a transformer, always switch power on and off to the controller from the transformer secondary. Turning power on and off in the transformer primary can cause controller damage.
3. Never use power factor correction capacitors on the input line to the controller. These capacitors can cause controller damage.
4. The wire size of the AC input power and motor wiring can be determined from Table 1.
5. All external wiring for low voltage signal sources, such as potentiometers, tachometer generators and transducers should be run in separate conduit from all other wiring. Use twisted cable. Maintain the separation of power and signal wires by 2" and cross these wires only at 90° angles. Minimum required wire size is 18 gauge, but check with your local electrical and safety codes, as well as National Electric Code (NEC).
6. Figures 1 and 2 show the connection for AC input power, DC motor and run speed potentiometer leads to the controller.
7. Refer to Page 6 for tachometer feedback instructions.
8. To protect the chassis controller, an AC line fuse, should be installed. When using 115VAC, the fuse should be installed in the "HOT" AC line. The fuse rating should be a minimum of 1.25 times the AC line currents in Table 1. Bussmann series ABC, Littelfuse Series 326 or equivalent should be used for 115 VAC and Bussman KTK or Gould ATM for 230 VAC.
9. Make sure the controller and motor housings are securely and adequately grounded.

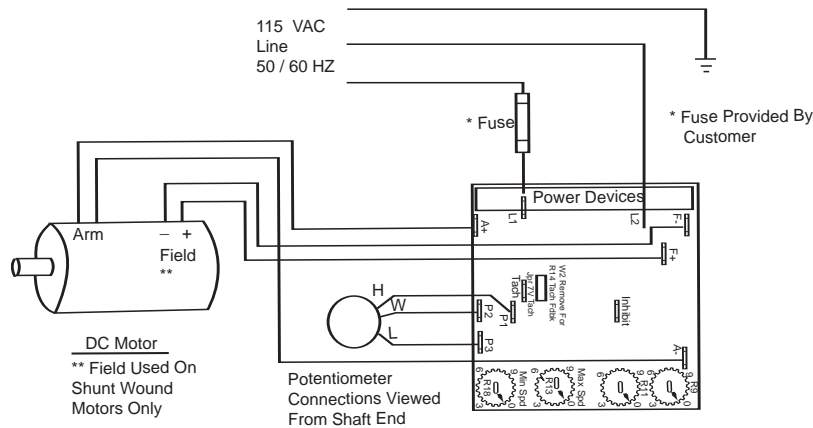

Figure 1 - DCX102C Connection

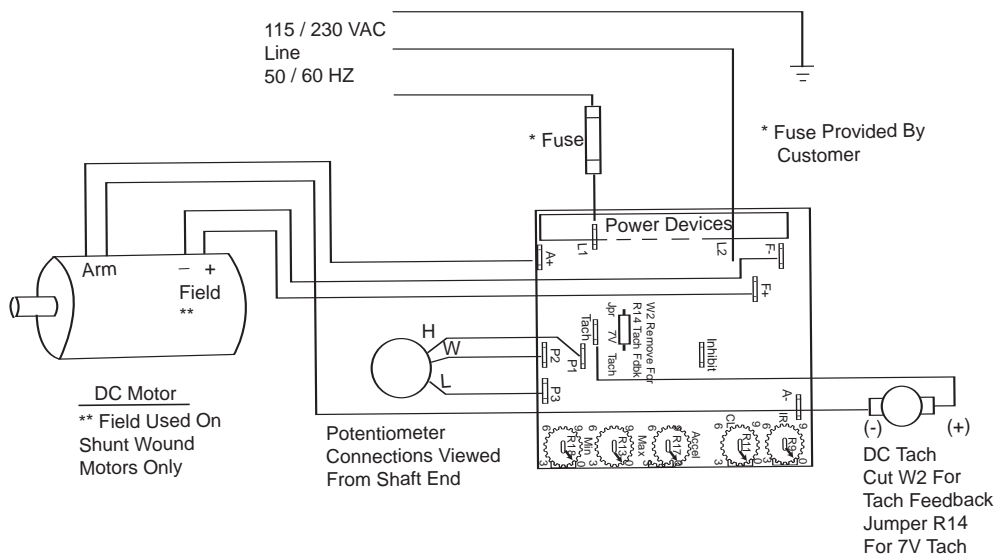

Figure 2 - DCX202C & DCX302C Connection

Initial Startup

1. Make sure AC Power is off.
2. Wire the motor, controller, run speed potentiometer and tachometer feedback (if applicable) per Figure 1 or 2 on Page 5. Make sure connections are tight.
3. Adjust the chassis controller calibration trim potentiometers per Table 2 for DCX102C, Table 3 for DCX202C and Table 4 for DCX302C controllers. Use the nearest horsepower rating and proper line voltage as a guide to setting the trim potentiometers.
4. Set the chassis controller's run speed potentiometer full counterclockwise.
5. Apply AC line power to the controller and with load on the motor, initiate the run mode. Next, turn the run speed potentiometer clockwise while observing the motor rotation. If motor rotates in the wrong direction, remove AC power to the controller. Then reverse the DC motor armature connections to the controller.
6. Apply AC line power to the controller and initiate the run mode. Check for satisfactory operation through-out the full speed range.
7. If acceleration is either too fast or too slow, or if the motor is surging in speed, or shows instability or has excessive speed, go to the controller trim potentiometer calibration procedure on Page 7.

The potentiometer adjustments shown in Tables 2, 3, and 4, were established on Boston Gear permanent magnet motors. Other motors may require a slightly different setting for the IR comp potentiometer. See calibration procedure on Pages 7 and 8.

Tachometer Feedback

(For Uni-directional Models Only)

DCX202C and DCX302C controllers are supplied with a tachometer feedback circuit for use with a 35, 50 or 100 VDC/1000 RPM signal. If a signal of 7VDC/1000 RPM is to be used, modify control per instructions below.

Refer to Figure 2 on Page 5.

1. Remove W2 jumper on printed circuit board.
2. Connect the negative tach signal lead to the A-connector and connect the positive tach signal to the tach connector. (We suggest the use of DCX-DP dual connecting PIN-67118.) Use twisted cable. (Do not use Shielded cable.) Maintain the separation of power and signal wires by 2 inches and cross these wires only at 90° angles.
3. Turn maximum speed (MAX SPD) trim potentiometer on controller full counterclockwise. Apply AC power and initiate run mode. Turn the run speed potentiometer full clockwise, then turn the "MAX SPD" potentiometer clockwise until you reach the motors base speed.

When using a 7 VDC/1000 RPM tach generator, Resistor R14 on the controller must be either jumpered or shorted.

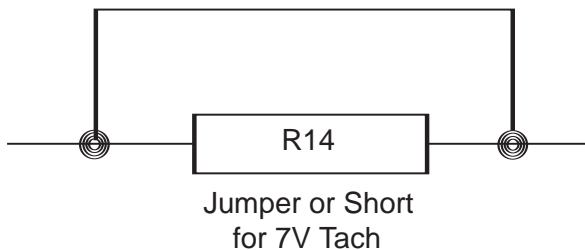

Figure 3

**Table 2 —
DCX102C Controller
Adjustment Chart**

IR Comp	Current Limit	Max Speed	Min Speed	Line Voltage	H.P.
				115	1/12
				115	1/6
				115	1/4
				115	1/3
				115	1/2

(Suggested initial start-up settings)

All of the potentiometer trim POTS, when turned full counterclockwise, should have the arrow on the white plastic guide (which sits on top of the POT) should be pointing to the zero mark on the board. If this is not the case, remove the plastic guide and repeat it with the arrow pointing to zero.

**Table 3 —
DCX202C Controller
Adjustment Chart**

Max Speed	Accel Decel	IR Comp	Current Limit	Min Speed	Line Voltage	H.P.
					115	1/12
					115	1/6
					115	1/4
					115	1/3
					115	1/2
					115	3/4
					115	1
					230	1/2
					230	3/4
					230	1
					230	1-1/2
					230	2

(Suggested initial start-up settings)

All of the potentiometer trim POTS, when turned full counterclockwise, should have the arrow on the white plastic guide (which sits on top of the POT) should be pointing to the zero mark on the board. If this is not the case, remove the plastic guide and repeat it with the arrow pointing to zero.

**Table 4 —
DCX302C Controller
Adjustment Chart**

Max Speed	Accel Decel	IR Comp	Current Limit	Min Speed	Line Voltage	H.P.
					115	1/12
					115	1/6
					115	1/4
					115	1/3
					115	1/2
					115	3/4
					115	1
					230	1/2
					230	3/4
					230	1
					230	1-1/2
					230	2
					230	3

(Suggested initial start-up settings)

All of the potentiometer trim POTS, when turned full counterclockwise, should have the arrow on the white plastic guide (which sits on top of the POT) should be pointing to the zero mark on the board. If this is not the case, remove the plastic guide and repeat it with the arrow pointing to zero.

Section III Calibration Procedure

Safety Precautions

This device should be installed, adapted and serviced by qualified electrical maintenance personnel familiar with the construction and operation of the equipment and the hazards involved.

⚠ WARNING Controller is not isolated from earth ground. Thus the printed circuit board and its components are at a potential of 115 or 230 VAC above ground and could cause serious injury. Please re-read safety warnings on Page 6.

⚠ CAUTION Use a non-metallic screwdriver when adjusting the controller trim potentiometers to avoid the metal screwdriver blade making contact with live circuitry and causing serious injury.

⚠ CAUTION Be sure that proper voltage is applied to the chassis controller (115 or 230 volts). Connecting the wrong voltage to the chassis controller may cause controller damage and void the warranty.

⚠ CAUTION Do not test or check circuit continuity by shorting terminals. This could cause disastrous failure and void warranty.

Equipment

The following equipment is required to calibrate DCX Chassis Controller:

AMMETER: 0-25 AMPS D.C.
TACHOMETER: To measure RPM

Procedure

Connect motor, AC line and run speed potentiometer per wiring instructions:

1. Remove AC line power from the controller.
2. Set run speed potentiometer full counterclockwise.
3. Set maximum speed (MAX SPD) trim potentiometer full counterclockwise.
4. Set minimum speed (MIN SPD) trim potentiometer full counterclockwise.
5. Set IR comp (IR) trim potentiometer full counterclockwise.
6. Set current limit (CL) trim potentiometer full clockwise.
7. Connect DC ammeter (0-25 amps) in series with an armature lead on the motor (see Figure 4).

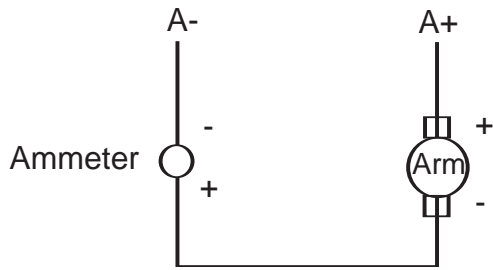

Figure 4

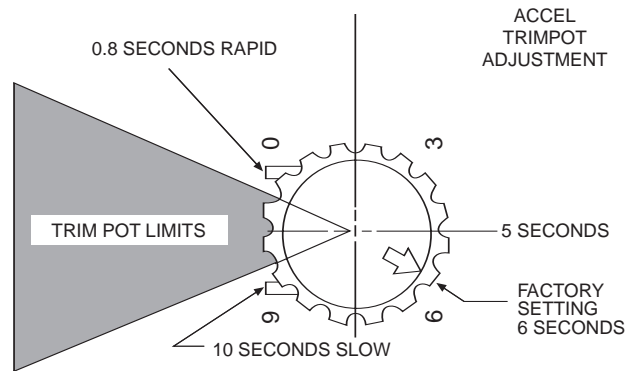

Figure 5

8. Set Accel/Decel (ACCEL) trim potentiometer on DCX202C and DCX302C controllers for the desired time. This potentiometer allows adjustable linear acceleration and deceleration with one potentiometer. The potentiometer can be adjusted from .8 to 10 seconds. See Figure 5.
9. Remove the load from the motor. Apply AC line power to the controller and initiate the run mode.
10. Set run speed potentiometer full clockwise. Adjust maximum speed trim potentiometer until the tachometer reads motor nameplate speed.
11. Set run speed potentiometer full counter clockwise. Adjust minimum speed trim potentiometer clockwise until motor begins to rotate, then slowly adjust it counterclockwise until the motor stops.
12. Repeat steps 10 and 11 until both maximum and minimum speeds are at their desired level.
13. IR compensation (speed regulation) – Adjust run speed potentiometer so that the motor is running at 1000 RPM. Apply full load to the motor and adjust IR trim (IR) potentiometer clockwise until the motor returns to 1000 RPM. If motor speed becomes unstable, turn the IR trim potentiometer counterclockwise until the instability goes away. The maximum speed trim potentiometer may now have to be readjusted (See Step 10).

14. Current Limit – Set run speed potentiometer full clockwise. Set current limit (CL) trim potentiometer full counterclockwise and the motor should stall. Remove power from control. Lock the motor shaft. Reapply power and adjust the current limit trim potentiometer clockwise until the armature current is 150% of the motor nameplate current.
15. Set run speed potentiometer full counter clockwise. Initiate a stop mode and then remove AC line power.
16. Unlock the motor shaft. The calibration is now complete.

Section IV Switching Circuits

1. **Run-stop with coast to stop.** The following circuit will allow the motor to start thru the controller's acceleration circuit and coast to a stop. The customer's SPDT (single pole, double-throw) run-stop switch is connected between the inhibit tab and the A- tab on the controller as shown below.

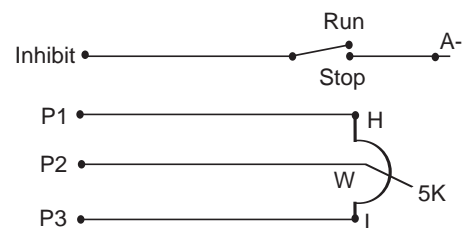

- Run-stop with deceleration to stop.** The following circuit will allow the motor to start thru the controller's acceleration circuit and stop thru the controller's deceleration circuit. The customer's SPDT (single pole, double-throw) run-stop switch is connected between the P1 tab on the controller and the high leg of the run speed potentiometer as shown below.

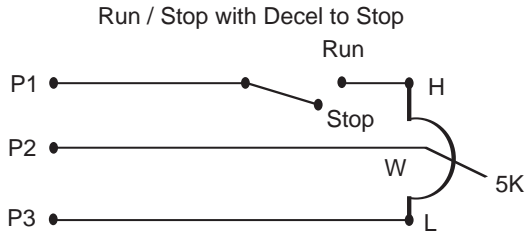

- Run-stop by AC line power switching.** The following circuit will allow the motor to start thru the controller's acceleration circuit and coast to a stop. The customer's DPDT (double pole, double throw) run-stop switch is connected between the AC line power and the L1 and L2 tabs on the controller as shown below.

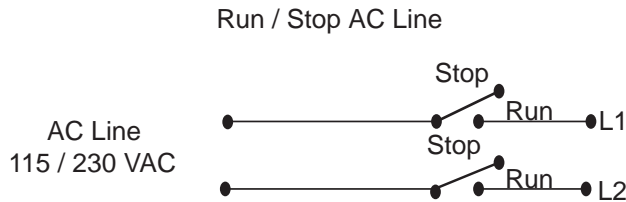

- Run-stop by armature switching (with or without dynamic braking).** The following circuit will allow the motor to start thru the controller's acceleration circuit. Stopping will either be a coast to stop (without braking resistor) or a quick stop (with braking resistor). The customer's DPDT (double pole, double-throw) run-stop switch is connected to the controller tabs (A+, A-, inhibit) and the motor armature as shown below.

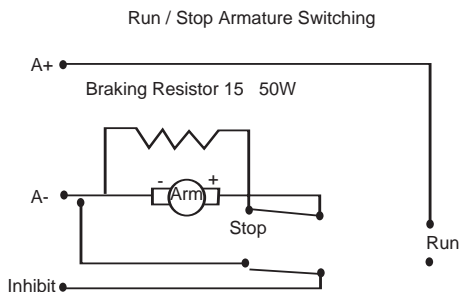

Note: Do not restart drive until motor stops rotating. Switch cannot break the DC braking current.

- Forward-Stop-Reverse by armature switching.** The following circuit will allow the motor to start in either forward or reverse direction thru the controller's acceleration circuit and coast to a stop. The customer's 3PDT, [3 pole, double throw, 3 position (center off)], switch is connected between controller tabs (A+, A-, inhibit) and the motor armature as shown below.

Note: Do not restart drive until motor stops rotating. Motor may become demagnetized.

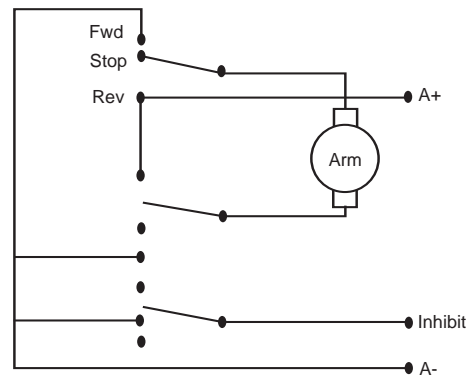

Dimensions DCX102C/DCX202C

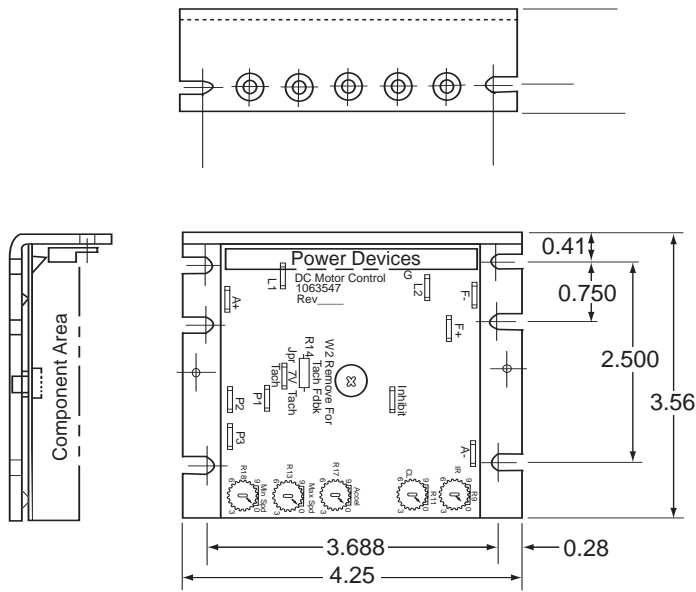

Note: Tach and Accel not available on DCX102C.

DCX-RHTSK

#6-32 Tap, 2 Places

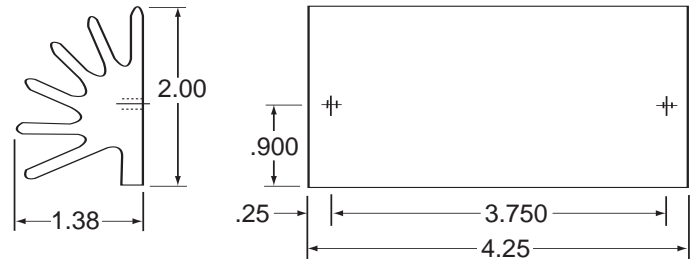

DCX302

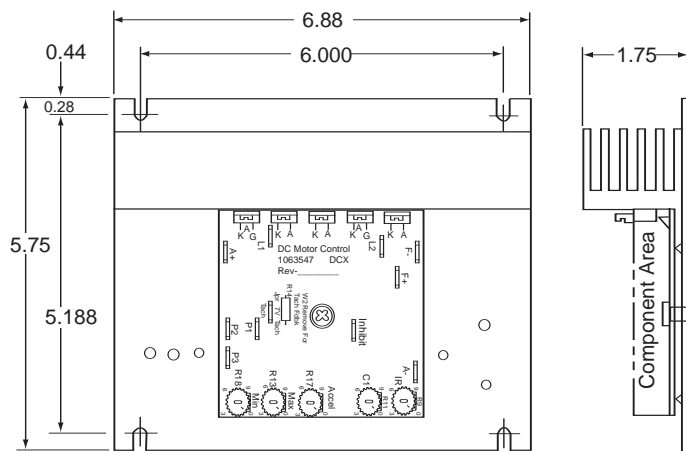

Note: Mount heatsink with fins vertical for best heat transfer.

DCX-HTSK

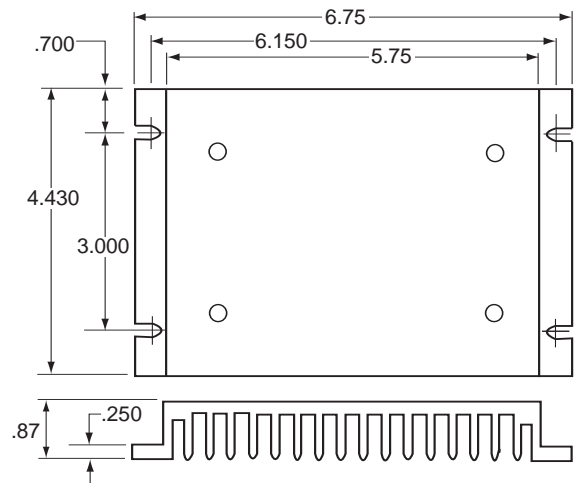

Options for Chassis Models

DCX-BTB2 68249
DCX-BTB3 68254

Barrier Terminal board

- Provides terminal strips for external wiring
- Fits over chassis models
- Plugs onto tab connectors
- Provided single AC line fuse holder (fuse not supplied)
- LED power “on” indicator

Input Voltage	Use Option
115 VAC	DCX-BTB2
230 VAC	DCX-BTB3

DCX-DA 65996
Start/Stop Board

- Allows motor start/stop via pushbuttons or external logic
- For use up to 1 HP (115 VAC) or 3 HP (230 VAC)
- Built-in dynamic braking
- Includes armature contactor and dynamic braking resistor

DCX-RA 65998
Reversing Board

- Allows motor forward/reverse operation via pushbuttons or external logic
- For use up to 1 HP (115 VAC) or 3 HP (230 VAC)
- Built-in dynamic braking
- Includes armature contactors, anti-plug circuitry and dynamic braking resistor

DCX-25A 68342
Isolation Board

- Isolated signal board for general-purpose use
- 4 to 20DCmA, 0 to 10VDC input
- Scaling pot for offset adjustment
- Compact size

DCX-DP 67118
Dual Connector Pin

- For use with tachometer feedback and/or inhibit
- Female connector with two male tabs
- Allows two connections to one tab

DCX-KDP 67109
Knob and Dial Plate Kit

- Contains knob for speed pot, label with 0 to 100% gradients

DCX-FBK 67114
Fuse Block Kit

- Contains fuse block, lead wire with spade connectors mounting screw (fuse not supplied)
- For line fusing

DCX-HTSK 67106
Heatsink Kit

- Base mounting
- Additional area provided for fuseblock kits
- Expands rating of DCX202C to 3/4 HP (115VAC) or 1-1/2 HP (230VAC)
- Kit includes all required hardware

DCX-RHTSK 67098
Radial Heatsink Kit

- Unique design allows smaller footprint than base mounted unit
- Adds 3/4" to height, 1-3/8" to length
- Expands rating of DCX202C to 1 HP (115VAC) or 2 HP (230VAC)
- Kit includes all required hardware.

Warranty

Boston Gear warrants that products manufactured or sold by it shall be free from defects in material and workmanship. Any products which shall within two (2) years of delivery, be proved to the Company's satisfaction to have been defective at the time of delivery in these respects will be replaced or repaired by the Company at its option. Freight is the responsibility of the customer. The Company's liability under this limited warranty is limited to such replacement or repair and it shall not be held liable in any form of action for direct or consequential damages to property or person. The foregoing limited warranty is expressly made in lieu of all other warranties whatsoever, express, implied and statutory and including without limitation the implied warranties of merchantability and fitness.

No employee, agent, distributor, or other person is authorized to give additional warranties on behalf of Boston Gear, nor to assume for Boston Gear any other liability in connection with any of its products, except an officer of Boston Gear by a signed writing.



Boston Gear
14 Hayward Street • Quincy, MA 02171
617-328-3300 • Fax: 617-479-6238
www.bostongear.com
a division of **Altra Industrial Motion**