

Boston Gear®

Motor Multiplier

Planetary Flanged Reductor

P-3037-BG

Installation and Operation

Doc. No. 83553

FSP Series



 **Boston**
Gear

a division of **Altra Industrial Motion**

General Instructions

This planetary Flanged Reductor is pre-lubricated for life. It is available with 5/8 or 7/8 inch output shaft diameters (Models FSP-5A & FSP-5 respectively). These models may be used as 5:1 ratio prefix modules on Boston Gear Flanged Reducers designed for 1/6 through 2 HP (Mounting Code II & III) motors or as in-line motorized Reducers, either base or face mounted.

Note: Both the planetary output shaft and motor shaft should be coated with Anti-Seize Compound.

Flange Reductor Prefix Installation

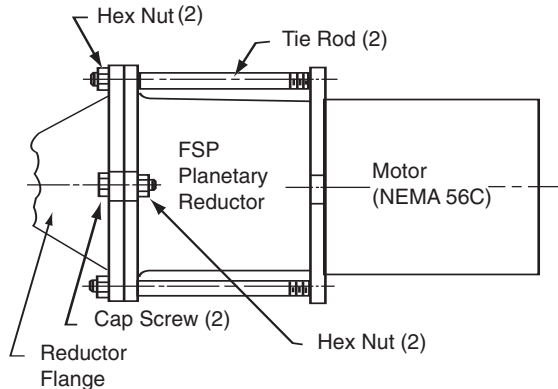

Assemble FSP Reductor onto selected Boston Gear Flanged Reductor while aligning projecting output shaft and key with Flanged Reductor input shaft bore and keyway. Fasten flanges together using two (2) 3/8-16 cap screws and nuts in any diagonally opposite holes. Insert two (2) tie rods through two (2) remaining bolt holes in flanges. Assemble motor onto FSP Reductor while aligning motor shaft and keyway with FSP Reductor input bore and key (key in an integral part of Reductor input bore). While holding in this position, thread tie rods into two (2) of the tapped holes in the motor face at least six (6) turns. Assemble the remaining hex nuts onto threaded end of tie rods and tighten securely. Complete installation following instructions furnished with the selected Flanged Reductor.

Face Mounted Installation

Assemble motor onto FSP Reductor while carefully aligning motor shaft and keyway with FSP Reductor input bore and key (key is an integral part of Reductor input bore). Insert tie rods through any two diagonally opposite holes in flange and into two (2) tapped holes in the motor face at least six (6) turns. Assemble two (2) hex nuts onto threaded ends of tie rods and tighten securely using care not to apply excessive torque that would distort ears on FSP Reductor flange. Excess tie rod length may be cut off at this time. Prior to securing the entire assembly to its mounting plate or surface, clearance should be provided for the 4-1/2 inch pilot diameter and the extension of tie rods and nuts. Mounting may now be completed using suitable fasteners through remaining two holes in mounting flange. If more rigid mounting is desired, tie rods may pass through plate onto which reductor is mounted, in which case the hex nuts may be installed on the ends that project through the plate. Maximum plate thickness with standard tie rods would be 3/8".

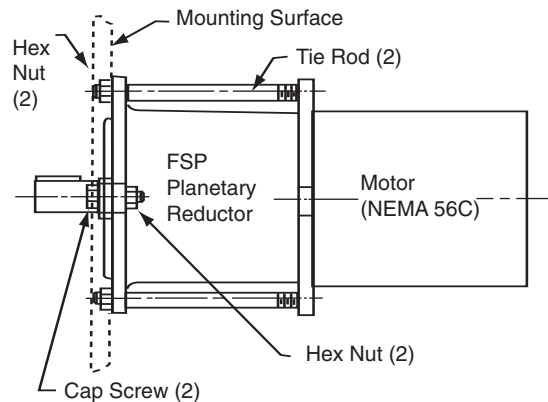

Base Mounted Installation

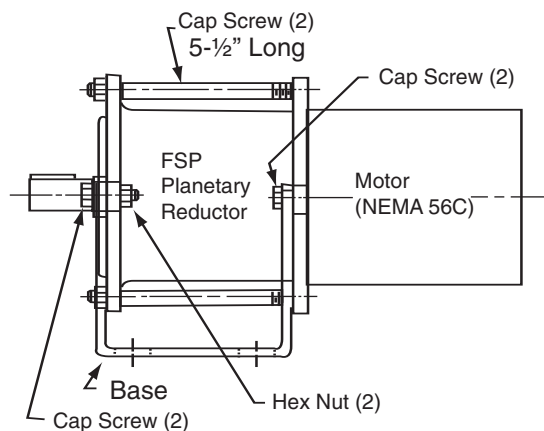

Assemble motor onto FSP Reductor while carefully aligning motor shaft and keyway with FSP Reductor input bore and key (key is an integral part of Reductor input bore). Insert 5-1/2" long cap screws through any two (2) diagonally opposite holes in flange and into two (2) tapped holes in motor face and tighten securely using care not to apply excessive torque that could distort ears of FSP Reductor flange. Place entire assembly into base mounting bracket so that bolt holes in bracket are aligned with two remaining bolt holes in both FSP Reductor flange and motor. Install bolts and nuts provided and tighten securely. Mount assembled Reducer in the desired mounting position and attach securely to a solid, sturdy foundation using maximum size bolts.

Warranty

The Company warrants that all series speed reducers will be free from defects in material and workmanship over the lifetime of the product.

Oil seals are considered to be replaceable maintenance items.

Any products which shall be proved to the Company's satisfaction to have been defective at the time of delivery in these respects will be replaced or repaired by the Company at its option. Freight is the responsibility of the customer. The Company's liability under this warranty is limited to such replacement or repair and it shall not be held liable in any form of action for direct or consequential damages to property or person. THE FOREGOING WARRANTY IS EXPRESSLY MADE IN LIEU OF ALL OTHER WARRANTIES WHATSOEVER, EXPRESS, IMPLIED AND STATUTORY AND INCLUDING WITHOUT LIMITATION THE IMPLIED WARRANTIES OF MERCHANTABILITY AND FITNESS.

No employee, agent, distributor, or other person is authorized to give additional warranties on behalf of Boston Gear, nor to assume for Boston Gear any other liability in connection with any of its products, except an officer of Boston Gear by a signed writing.



Boston Gear
14 Hayward Street • Quincy, MA 02171
617-328-3300 • Fax: 617-479-6238
www.bostongear.com
a division of **Altra Industrial Motion**