

Modular “Building Block” Clutches

AL/ALM

Overrunning, Indexing Ball Bearing Supported, Ramp & Roller Clutches



The model AL and ALM clutches are part of a Modular Building Block System. They are a ramp & roller type clutch that is ball bearing supported. Covers are used to transmit the torque and enclose the clutch, making it self-contained. A variety of cover designs are available and the cover combination selected would be based upon the drive arrangement. The bearings in this design cannot accept axial loads. These clutches are primarily used in overrunning and indexing applications. These clutches are oil lubricated.

This clutch is designed for oil lubrication. For grease lubrication, reduce the maximum overrunning speed to 50% of listed value.

For bolt tightening torque values, see page 132.

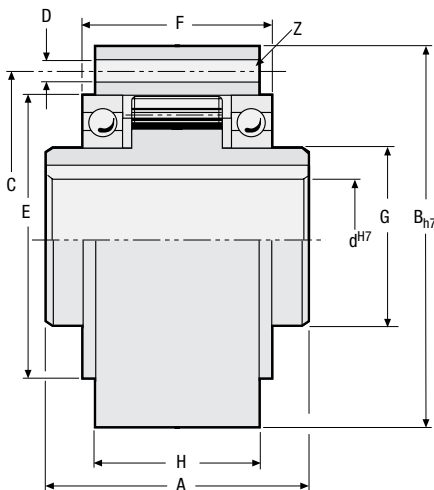

Specifications

Model	Size	Torque Capacity lb.ft. (Nm)	Overrunning Speed Max. RPM		Resistance after run-in lb.in. (Ncm)	Shipping Weight lb. (kg)
			Inner Race	Outer Race		
AL	12	41 (55)	2,500	7,200	0.3 (3.4)	1.3 (0.6)
	15	92 (125)	1,900	6,500	0.3 (4.1)	2.0 (0.9)
	20	134 (181)	1,600	5,600	0.7 (8)	2.6 (1.2)
	25	213 (288)	1,400	4,500	1.3 (14)	4.0 (1.8)
	30	369 (500)	1,300	4,100	2.1 (23)	5.3 (2.4)
	35	535 (725)	1,100	3,800	5.4 (60)	6.8 (3.1)
	40	756 (1025)	950	3,400	6.5 (72)	10.6 (4.8)
	45	830 (1125)	900	3,200	12.6 (140)	11 (4.9)
	50	1,568 (2125)	850	2,800	16.2 (180)	16 (6.9)
	55	1,937 (2625)	720	2,650	17.1 (190)	20 (9)
	60	2,583 (3500)	680	2,450	21.6 (240)	24 (11)
	70	4,244 (5750)	580	2,150	28.8 (320)	31 (14)
	80	6,273 (8500)	480	1,900	29.7 (330)	40 (18)
	90	10,701 (14500)	380	1,700	58.5 (650)	60 (27)
	100	14,760 (20000)	350	1,450	74.7 (830)	101 (46)
120	23,063 (31250)	250	1,250	97.2 (1080)	139 (63)	
150	51,660 (70000)	180	980	111.6 (1240)	282 (128)	
200	129,150 (175000)	120	750	342 (3800)	650 (293)	
250	212,175 (287500)	100	620	549 (6100)	1,034 (469)	
ALM	25	286 (388)	1,100	2,800	1.9 (22)	3.7 (1.8)
	30	434 (588)	1,000	2,500	3.3 (37)	5.3 (2.5)
	35	618 (838)	900	2,400	5.9 (66)	7.0 (3.2)

Modular “Building Block” Clutches

AL/ALM

Dimensions inches (mm)

Model	Size	A	B _{h7}	C	D	E	F	G	H ⁽¹⁾	Z
				Bolt Circle Dia.	Bolt Hole Dia. (No. Holes)					
AL	12	1.654 (42)	2.44 (62)	2.008 (51)	.217 (3) (5.5)	1.654 (42)	1.063 (27)	.787 (20)	.799 (20.3)	3
	15	2.047 (52)	2.67 (68)	2.205 (56)	.217 (3) (5.5)	1.850 (47)	1.343 (34.1)	.984 (25)	1.193 (30.3)	3
	20	2.244 (57)	2.953 (75)	2.520 (64)	.217 (4) (5.5)	2.165 (55)	1.539 (39.1)	1.181 (30)	1.350 (34.3)	4
	25	2.362 (60)	3.543 (90)	3.071 (78)	.217 (6) (5.5)	2.677 (68)	1.657 (42.1)	1.575 (40)	1.469 (37.3)	6
	30	2.677 (68)	3.937 (100)	3.425 (87)	.260 (6) (6.6)	2.953 (75)	1.933 (49.1)	1.772 (45)	1.744 (44.3)	6
	35	2.913 (74)	4.331 (110)	3.780 (96)	.260 (6) (6.6)	3.150 (80)	2.130 (54.1)	1.969 (50)	1.902 (48.3)	6
	40	3.386 (86)	4.921 (125)	4.252 (108)	.354 (6) (9)	3.543 (90)	2.445 (62.1)	2.165 (55)	2.217 (56.3)	6
	45	3.386 (86)	5.118 (130)	4.409 (112)	.354 (8) (9)	3.740 (95)	2.445 (62.1)	2.362 (60)	2.217 (56.3)	8
	50	3.622 (92)	5.906 (150)	5.197 (132)	.354 (8) (9)	4.331 (110)	2.720 (69.1)	2.756 (70)	2.492 (63.3)	8
	55	4.094 (104)	6.299 (160)	5.433 (138)	.433 (8) (11)	4.528 (115)	2.878 (73.1)	2.953 (75)	2.638 (67)	8
	60	4.488 (114)	6.693 (170)	5.906 (150)	.433 (10) (11)	4.921 (125)	3.307 (84)	3.150 (80)	3.071 (78)	10
	70	5.276 (134)	7.480 (190)	6.496 (165)	.433 (10) (11)	5.512 (140)	4.056 (103)	3.543 (90)	3.740 (95)	10
	80	5.669 (144)	8.268 (210)	7.283 (185)	.433 (10) (11)	6.299 (160)	4.882 (108)	4.133 (105)	3.937 (100)	10
	90	6.220 (158)	9.055 (230)	8.110 (206)	.551 (10) (14)	7.087 (180)	5.630 (125)	4.724 (120)	4.528 (115)	10
	100	7.165 (182)	10.630 (270)	9.449 (240)	.709 (10) (18)	8.268 (210)	5.157 (131)	5.512 (140)	4.724 (120)	10
120	7.953 (202)	12.205 (310)	10.945 (278)	.709 (12) (18)	9.449 (240)	5.984 (152)	6.299 (160)	5.512 (140)	12	
150	9.685 (246)	15.748 (400)	14.173 (360)	.866 (12) (22)	12.205 (310)	7.717 (190)	7.874 (200)	7.087 (180)	12	
200	12.834 (326)	20.472 (520)	18.110 (460)	1.024 (18) (26)	15.748 (400)	10.433 (265)	10.236 (260)	9.449 (240)	18	
250	15.591 (396)	24.016 (610)	21.457 (545)	1.299 (20) (33)	18.898 (480)	12.992 (330)	12.598 (320)	11.811 (300)	20	
ALM	25	2.362 (60)	3.543 (90)	3.071 (78)	.217 (6) (5.5)	2.677 (68)	1.657 (42.1)	1.575 (40)	1.468 (37.3)	6
	30	2.677 (68)	3.937 (100)	3.425 (87)	.260 (6) (6.6)	2.953 (75)	1.933 (49.1)	1.772 (45)	1.744 (44.3)	6
	35	2.913 (74)	4.331 (110)	3.780 (96)	.260 (6) (6.6)	3.150 (80)	2.130 (54.1)	1.969 (50)	1.902 (48.3)	6

Bore sizes and keyseats inches (mm)

Size	d ^{H7} Bore Size	Keyseat*	Bore Range	
			Min.	Max.
12	.47 (12)	(4 X 1.8)	.354	.550
15	.59 (15)	(5 X 2.3)	.433	.689
20	.79 (20)	(6 X 2.8)	.433	.689
25	.98 (25)	(8 X 3.3)	.551	1.102
30	1.18 (30)	(8 X 3.3)	.748	1.338
35	1.38 (35)	(10 X 3.3)	.944	1.496
40	1.57 (40)	(12 X 3.3)	1.102	1.692
45	1.77 (45)	(14 X 3.8)	1.102	1.811
50	1.97 (50)	(14 X 3.8)	1.496	2.165
55	2.17 (55)	(16 X 4.3)	1.496	2.362
60	2.36 (60)	(18 X 4.4)	1.890	2.440
70	2.76 (70)	(20 X 4.9)	1.890	2.874
80	3.15 (80)	(22 X 5.4)	2.165	3.385
90	3.54 (90)	(25 X 5.4)	2.362	3.779
100	3.94 (100)	(28 X 6.4)	2.755	4.488
120	4.72 (120)	(32 X 7.4)	3.149	4.803
150	5.91 (150)	(36 X 8.4)	3.937	6.614
200	7.87 (200)	—	4.724	8.740
250	9.84 (250)	—	5.905	10.708
25	.98 (25)	(8 X 3.3)	.551	1.102
30	1.18 (30)	(8 X 3.3)	.748	1.338
35	1.38 (35)	(10 X 3.3)	.944	1.496

Notes:

⁽¹⁾ The dimension “H” for models 12 to 50 have sealing discs. Both sides add .010 inches (.25 mm) for each disc. From model 55 and up, without sealing discs, use “O” ring seals.

* For keyseat sizes see DIN6885.1 table on page 127.