

Modular “Building Block” Clutches

AL..F2D2, AL..F4D2; ALM..F2D2, ALM..F4D2

Overrunning, Indexing, Backstopping Ball Bearing Supported, Ramp & Roller Clutches

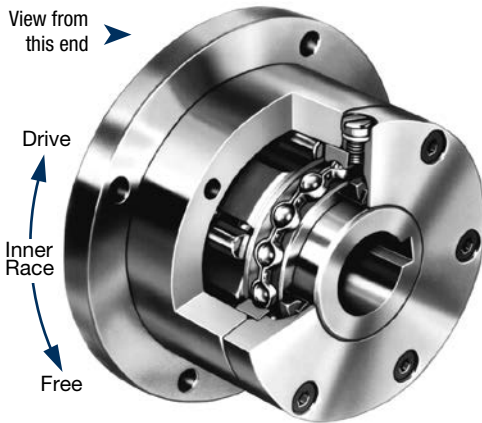

Right Hand rotation shown.
(Left Hand opposite.)

Specify direction of rotation when ordering.

The Model ALM clutch is a modified design for higher torque and lower overrunning speed applications.

This clutch is designed for oil lubrication. For grease lubrication, reduce the maximum overrunning speed to 50% of listed value.

Specifications

Model	Size	Torque Capacity lb.ft. (Nm)	Overrunning Speed Max. RPM		Resistance after run-in lb.in. (Ncm)	Shipping Weight lb. (kg)
			Inner Race	Outer Race		
AL..F2D2 AL..F4D2	12	41 (55)	2,500	7,200	1.0 (11)	1.98 (0.9)
	15	92 (125)	1,900	6,500	1.3 (15)	2.87 (1.3)
	20	134 (181)	1,600	5,600	1.6 (18)	3.75 (1.7)
	25	213 (288)	1,400	4,500	3.2 (36)	5.73 (2.6)
	28	369 (500)	1,300	4,100	.35 (4)	7.72 (3.5)
	30	369 (500)	1,300	4,100	.35 (4)	7.72 (3.5)
	35	535 (725)	1,100	3,800	5.3 (60)	9.92 (4.5)
	40	756 (1025)	950	3,400	7.4 (84)	15.21 (6.9)
	45	830 (1125)	900	3,200	8.3 (94)	15.66 (7.1)
	50	1,568 (2125)	850	2,800	11.3 (128)	22.27 (10.1)
	55	1,937 (2625)	720	2,650	13.3 (150)	28.89 (13.1)
	60	2,583 (3500)	680	2,450	14.2 (160)	34.40 (15.6)
	70	4,244 (5750)	580	2,150	31.9 (360)	44.98 (20.4)
	80	6,273 (8500)	480	1,900	31.9 (360)	58.87 (26.7)
	90	10,701 (14500)	380	1,700	60.2 (680)	86.00 (39)
	100	14,760 (20000)	350	1,450	77.9 (880)	145.53 (66)
	120	23,063 (31250)	250	1,250	106.2 (1200)	200.66 (91)
150	51,660 (70000)	180	980	119.5 (1350)	410.13 (186)	
200	129,150 (175000)	120	750	371.7 (4200)	937.12 (425)	
250	212,175 (287500)	100	620	575.3 (6500)	1,499.4 (680)	
ALM..F2D2 ALM..F4D2	25	286 (388)	1,100	2,800	3.6 (41)	5.95 (2.7)
	30	434 (588)	1,000	2,500	5.7 (64)	8.05 (3.65)
	35	618 (838)	900	2,400	6.7 (76)	10.36 (4.7)

Note: When ordering, please specify direction of rotation.

Modular “Building Block” Clutches

AL..F2D2, AL..F4D2; ALM..F2D2, ALM..F4D2

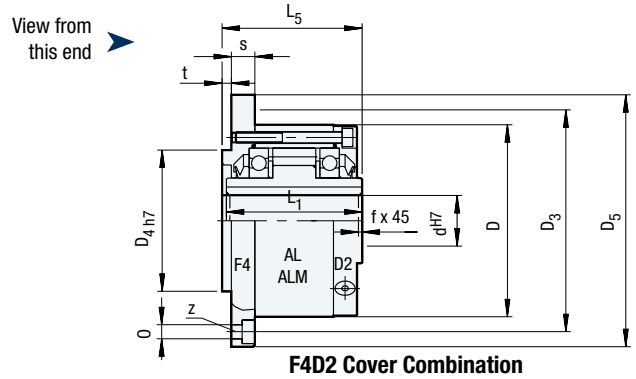
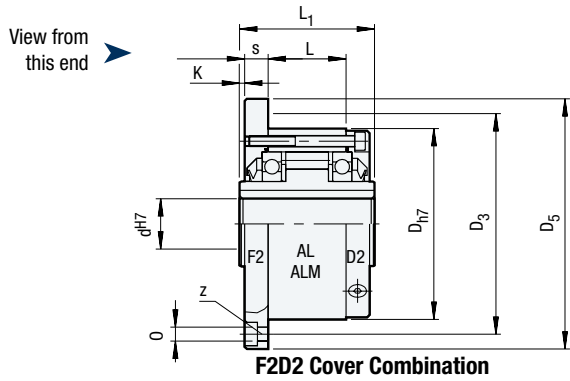

Dimensions inches (mm)

Model	Size	d ^{H7}	D _{h7}	L ₁	D ₅	D ₃	z	0	D _{4h7}	t	L ₅	K	s	f
AL..F2D2 AL..F4D2	12	0.47 (12)	2.44 (62)	1.65 (42)	3.35 (85)	2.83 (72)	3	0.22 (5.5)	1.65 (42)	0.12 (3)	1.73 (44)	0.02 (0.5)	0.41 (10.3)	0.02 (0.5)
	15	0.59 (15)	2.68 (68)	2.05 (52)	3.62 (92)	3.07 (78)	3	0.22 (5.5)	1.85 (47)	0.12 (3)	2.13 (54)	0.02 (0.5)	0.41 (10.3)	0.03 (0.8)
	20	0.79 (20)	2.95 (75)	2.24 (57)	3.86 (98)	3.35 (85)	4	0.22 (5.5)	2.17 (55)	0.12 (3)	2.32 (59)	0.02 (0.5)	0.43 (10.8)	0.03 (0.8)
	25	0.98 (25)	3.54 (90)	2.36 (60)	4.65 (118)	4.09 (104)	6	0.26 (6.6)	2.68 (68)	0.12 (3)	2.44 (62)	0.02 (0.5)	0.41 (10.5)	0.04 (1)
	28	1.18 (30)	3.94 (100)	2.68 (68)	5.04 (128)	4.49 (114)	6	0.26 (6.6)	2.95 (75)	0.12 (3)	2.76 (70)	0.02 (0.5)	0.44 (11.3)	0.04 (1)
	30	1.18 (30)	3.94 (100)	2.68 (68)	5.04 (128)	4.49 (114)	6	0.26 (6.6)	2.95 (75)	0.12 (3)	2.76 (70)	0.02 (0.5)	0.44 (11.3)	0.04 (1)
	35	1.38 (35)	4.33 (110)	2.91 (74)	5.43 (138)	4.88 (124)	6	0.26 (6.6)	3.15 (80)	0.14 (3.5)	2.99 (76)	0.04 (1)	0.46 (11.8)	0.04 (1)
	40	1.57 (40)	4.92 (125)	3.39 (86)	6.30 (160)	5.59 (142)	6	0.35 (9)	3.54 (90)	0.14 (3.5)	3.46 (88)	0.04 (1)	0.54 (13.8)	0.06 (1.5)
	45	1.77 (45)	5.12 (130)	3.39 (86)	6.50 (165)	5.75 (146)	8	0.35 (9)	3.74 (95)	0.14 (3.5)	3.46 (88)	0.04 (1)	0.54 (13.8)	0.06 (1.5)
	50	1.97 (50)	5.91 (150)	3.62 (92)	7.28 (185)	6.54 (166)	8	0.35 (9)	4.33 (110)	0.16 (4)	3.70 (94)	0.04 (1)	0.50 (12.8)	0.06 (1.5)
	55	2.17 (55)	6.30 (160)	4.09 (104)	8.03 (204)	7.17 (182)	8	0.43 (11)	4.53 (115)	0.16 (4)	4.17 (106)	0.06 (1.5)	0.66 (16.8)	0.08 (2)
	60	2.36 (60)	6.69 (170)	4.49 (114)	8.43 (214)	7.56 (192)	10	0.43 (11)	4.92 (125)	0.16 (4)	4.57 (116)	0.06 (1.5)	0.64 (16.3)	0.08 (2)
	70	2.76 (70)	7.48 (190)	5.28 (134)	9.21 (234)	8.35 (212)	10	0.43 (11)	5.51 (140)	0.16 (4)	5.35 (136)	0.06 (1.5)	0.70 (17.8)	0.10 (2.5)
	80	3.15 (80)	8.27 (210)	5.67 (144)	10.00 (254)	9.13 (232)	10	0.43 (11)	6.30 (160)	0.16 (4)	5.76 (146.3)	0.06 (1.5)	0.80 (20.3)	0.10 (2.5)
	90	3.54 (90)	9.06 (230)	6.22 (158)	10.94 (278)	10.00 (254)	10	0.55 (14)	7.09 (180)	0.18 (4.5)	6.34 (161)	0.06 (1.5)	0.79 (20)	0.12 (3)
100	3.94 (100)	10.63 (270)	7.17 (182)	13.19 (335)	12.01 (305)	10	0.71 (18)	8.27 (210)	0.20 (5)	7.24 (184)	0.10 (2.5)	1.10 (28)	0.12 (3)	
120	4.72 (120)	12.20 (310)	7.95 (202)	14.76 (375)	13.58 (345)	12	0.71 (18)	9.45 (240)	0.20 (5)	8.03 (204)	0.10 (2.5)	1.12 (28.5)	0.12 (3)	
150	5.91 (150)	15.75 (400)	9.69 (246)	19.09 (485)	17.52 (445)	12	0.87 (22)	12.20 (310)	0.20 (5)	9.80 (249)	0.10 (2.5)	1.22 (31)	0.16 (4)	
200	7.87 (200)	20.47 (520)	12.83 (326)	24.61 (625)	22.24 (565)	18	1.02 (26)	15.75 (400)	0.20 (5)	12.91 (328)	0.12 (3)	1.57 (40)	0.20 (5)	
250	9.84 (250)	24.02 (610)	15.59 (396)	29.13 (740)	26.77 (680)	20	1.30 (33)	18.90 (480)	0.20 (5)	15.67 (398)	0.12 (3)	1.77 (45)	0.20 (5)	
ALM..F2D2 ALM..F4D2	25	.098 (25)	3.54 (90)	2.36 (60)	4.65 (118)	4.09 (104)	4	0.26 (6.6)	2.68 (68)	0.12 (3)	2.44 (62)	0.02 (0.5)	0.41 (10.5)	0.04 (1)
	30	1.18 (30)	3.94 (100)	2.68 (68)	5.04 (128)	4.49 (114)	6	0.26 (6.6)	2.95 (75)	0.12 (3)	2.76 (70)	0.02 (0.5)	0.44 (11.3)	0.04 (1)
	35	1.38 (35)	4.33 (110)	2.91 (74)	5.43 (138)	4.88 (124)	6	0.26 (6.6)	3.15 (80)	0.14 (3.5)	2.99 (76)	0.04 (1)	0.46 (11.8)	0.04 (1)

Note: For bore and keyseat information see page 91.