

Modular “Building Block” Clutches

Building Block System

Modular Components Offer Extensive Combinations

The Models AL, GFR and RIZ have a modular design that offers a wide range of mounting options. A variety of cover, torque arm and coupling designs that can be assembled to the base clutch result in a mounting flexibility to meet any application.

AL

The model AL..clutch assembled with the F2 and D2 covers provides a versatile clutch assembly. The F2 cover provides mounting holes countersunk from the outboard side which are used to secure and drive a gear or pulley mounted over the outer race. This mounting configuration provides the highest radial load capacity as the line of force from the gear or sprocket is located between the clutch bearings. The D2 cover encloses the other end of the clutch for through shaft mounting.



GFR

The model GFR clutch assembled with the F3 and F4 covers results in an excellent low speed backstop. The F3 cover encloses one side of the clutch and provides the torque arm with integrated restraining bolt necessary for backstopping applications. The F4 cover encloses the other side of the clutch and provides extra room for end of shaft restraint as well as added oil capacity.

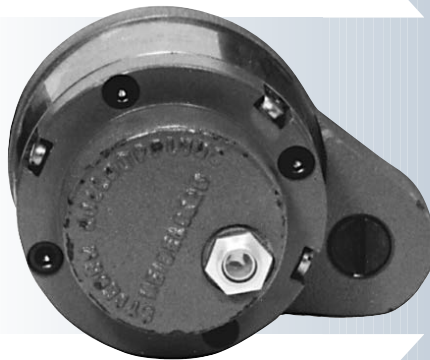

RINZ

The model RINZ clutch assembled with the G5 covers on both sides provides a durable easy-to-use design. The G5 cover provides axial restraint of a gear or pulley mounted on the outer race. Torque is transmitted to the gear or pulley by the key located in the outer race outside keyseat.

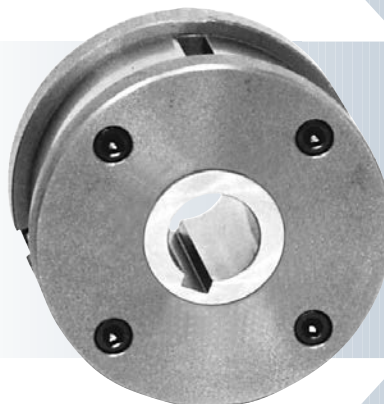

Modular “Building Block” Clutches

Building Block System Clutch and Cover Combinations

Covers

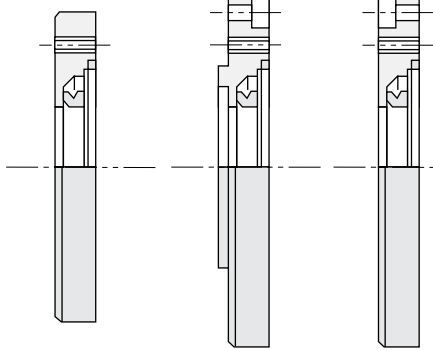

F7

F4

F2

Clutch

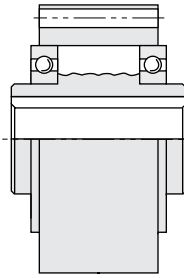

AL/ALM
ALP/ALPM

Covers

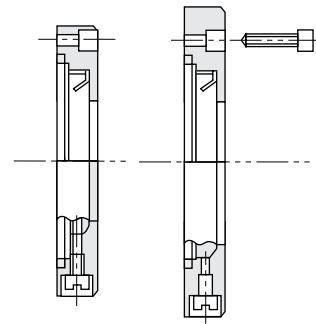

D2

D7

Covers

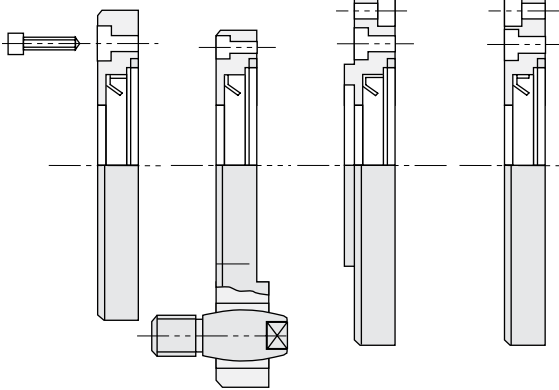

F5

F3

F7

F1

Clutch

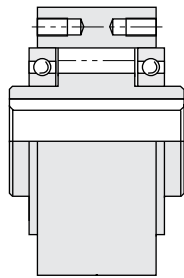

GFR, GFRN

Covers

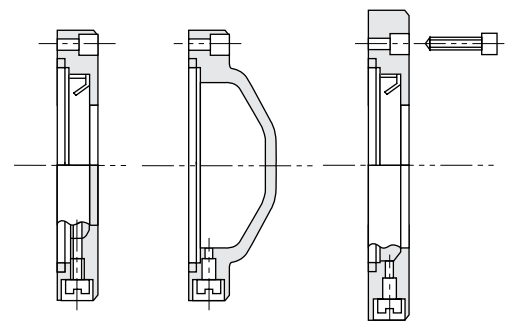

F2

F4

F6

Covers

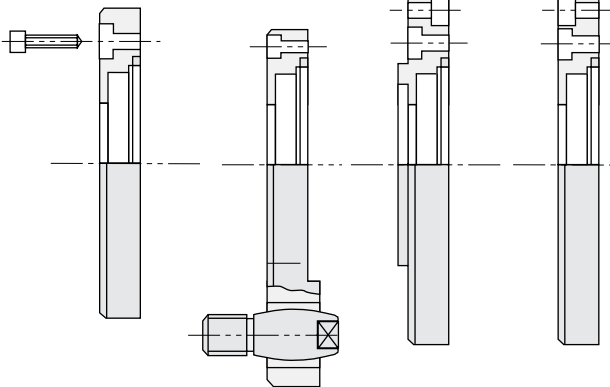

G5

G3

G7

G1

Clutch

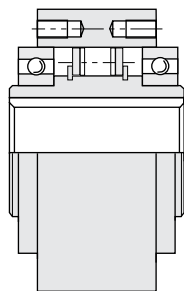

RIZ
RINZ

Covers

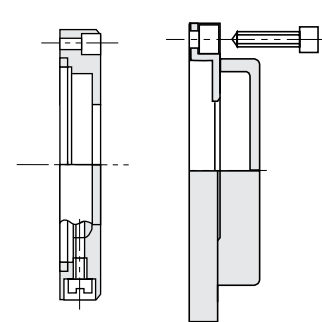

G2

G4