

Special Purpose Clutches

CDU

Overrunning, Inline, Standby and Creep Drive Operation Ball Bearing Supported, Sprag Clutches

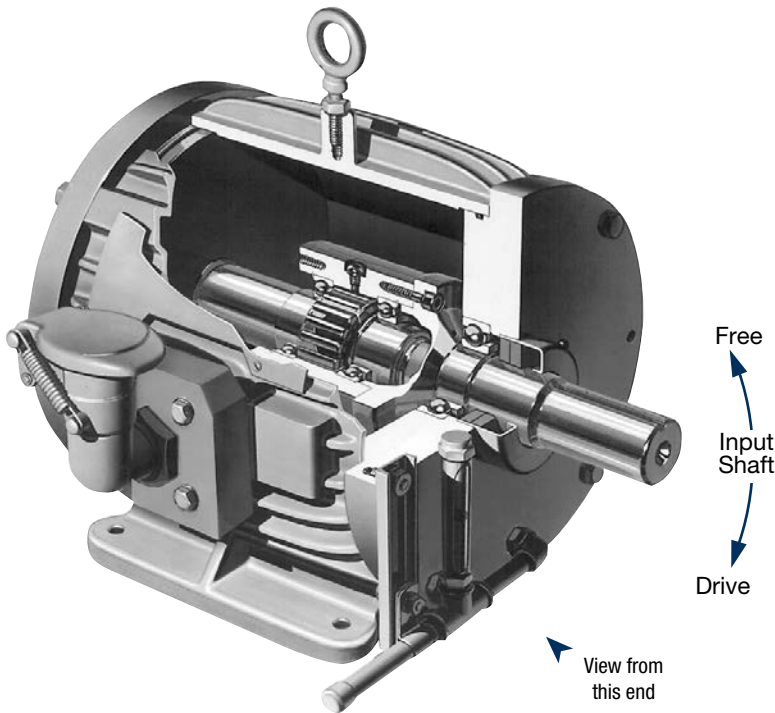

Right Hand rotation shown. (Left Hand opposite.)
Specify direction of rotation when ordering.

Continuous drive units are intended for use in continuous overrunning applications where the system cannot be shut down for maintenance and for applications in extremely harsh and dusty environments such as coal handling systems.

A CDU consists of an FSO overrunning, sprag clutch installed in a foot-mounted housing which encloses a generous supply of oil. The large oil volume along with the high dissipation capability of the finned housing permits extended service periods between oil changes. An oil sight gauge is mounted on each CDU for quick and easy monitoring of the oil level. Oil can be added without stopping the machine. The entire unit is sealed. Grease barrier seals minimize contamination and wear of the oil seals in environments with abrasive material.

The overrunning clutch internal to the CDU-500 through 1051 is oil dipped at the factory but *must be filled to the proper level before operation.*

For further information see Instruction and Maintenance Bulletin No. A-3038, P-222-23. Contact Formsprag application engineering department on indirect drive applications.

Sprag assemblies available

All CDUs have ultra-hard Formchrome® sprags which provide extra-long life, maximum wear resistance, and lower maintenance costs. Formchrome sprags, exclusive with Formsprag, are made by diffusing chromium into the surface of a hardened high carbon steel to form a chromium-carbide alloy. Models 500, 600 and 700 are equipped with PCE (Positive Continuous Engagement) sprags which are designed to overcome the effects of torsional vibration and high transient torque. C/T (Centrifugal Throw-out) sprags, which lift-off of the inner race, thereby eliminating overrunning wear, are available in all models.

Features

PCE Sprags

Help prevent clutch damage due to transient overloads or torsional vibrations

Formchrome Sprags with 70 Rc Hardness

Maximum wear life for extended clutch service

Large Oil Reservoir

Minimum maintenance (increased lubrication capacity)

Grease Barrier Seals

Protects oil seals from dusty and abrasive conditions providing extended seal life

Oil Fill and Drain Ports

Ease of maintenance

Breather

Pressure equalization without affecting oil seals

Foot Mounted Unit

Stand alone unit provides for easy access, installation and removal without disturbing equipment

Optional Centrifugal Throw-out (C/T) Sprag Design

Provides extended clutch life by eliminating rubbing contact of sprags during overrunning portion of duty cycle

Oil Sight Gauge

Provides a convenient method for checking oil level with CDU in operation

Applications

The CDUs in this catalog are designed for inline drives only. Applications for these self-contained foot-mounted continuous drive units are creep drives, turning gear drives, dual drives, energy recovery drives, and standby drives. C/T may be used in installations such as creep drives and turning gear drives where the drive speed is well below the overrunning speed.

For CDU installations requiring offset drives, contact Formsprag.

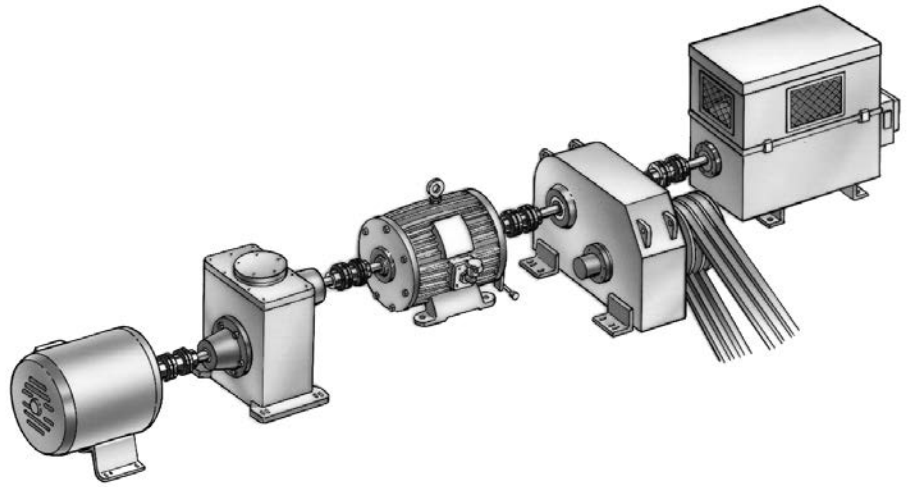

Creep (Low) Speed Drive

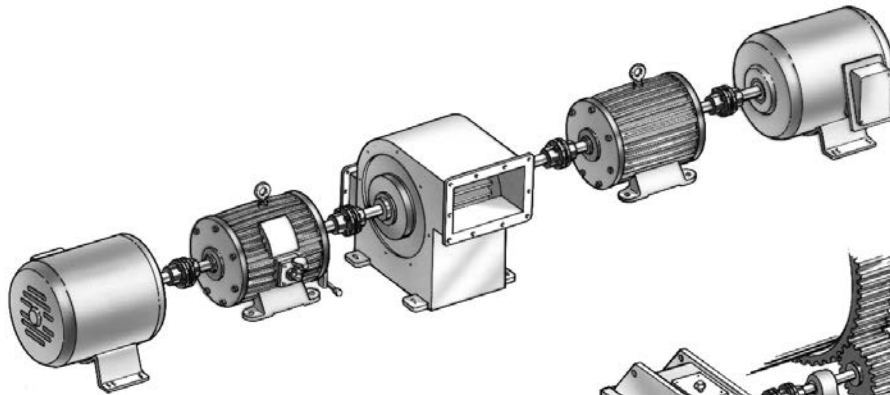

Dual Drive

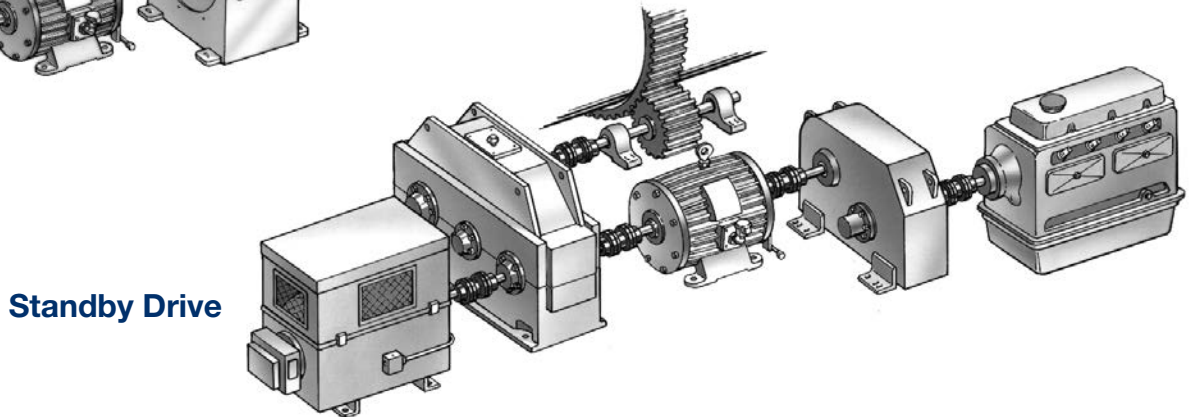

Standby Drive

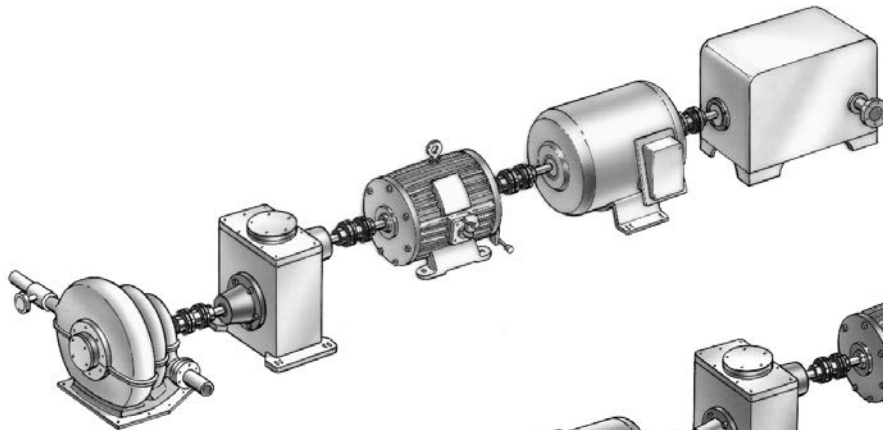

Energy Saving Drive

Turning Gear Drive

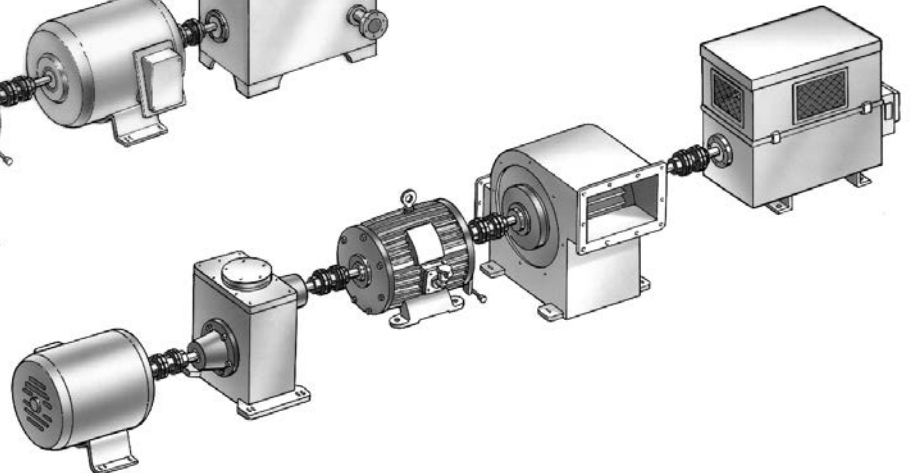

Special Purpose Clutches

CDU

Specifications

| Size | Torque Capacity lb.ft. (Nm) | Maximum RPM | | | | | Resistance after run-in lb.ft. (Nm) | Shipping Weight lb. (kg) |
|------|-----------------------------------|----------------|-------------|-----------|----------------|-------------|---|--------------------------------|
| | | Standard Model | | C/T Model | | | | |
| | | Driving | Overrunning | Driving | Sprag lift-off | Overrunning | | |
| 500 | 1,175 (1593) | 3,600 | 3,600 | 1,000 | 1,200 | 3,600 | .45 (.61) | 125 (57) |
| 600 | 2,250 (3051) | 3,600 | 3,600 | 1,000 | 1,200 | 3,600 | .90 (1.22) | 135 (61) |
| 700 | 5,000 (6780) | 2,000 | 2,000 | 800 | 1,000 | 2,000 | 2.13 (2.89) | 529 (240) |
| 750 | 7,000 (9492) | 1,800 | 1,800 | 650 | 800 | 1,800 | 7.50 (10.16) | 570 (259) |
| 800 | 13,000 (17628) | 1,500 | 1,500 | 525 | 675 | 1,500 | 10.50 (14.23) | 836 (389) |
| 900 | 18,000 (24408) | 1,350 | 1,350 | 500 | 650 | 1,350 | 12.50 (16.94) | 890 (404) |
| 1027 | 27,000 (36600) | 1,100 | 1,100 | 375 | 475 | 1,100 | 20.00 (27.10) | 1,289 (584) |
| 1051 | 45,000 (61010) | 1,100 | 1,100 | 375 | 475 | 1,100 | 24.00 (32.52) | 1,339 (607) |

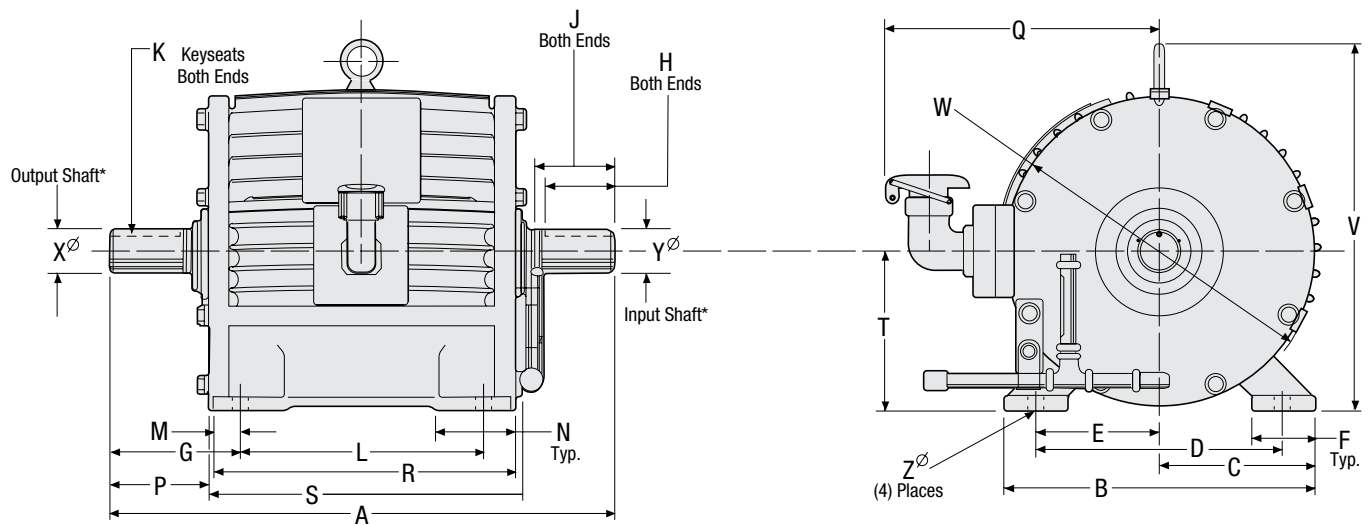

*For C/T models, the input and output shaft diameters are reversed.

Dimensions inches (mm)

| Size | A | B | C | D | E | F | G | L | M | N | P | Q | R | S | T | V | W | Z |
|------|--------------------|-------------------|-------------------|-------------------|------------------|------------------|-------------------|-------------------|-----------------|------------------|-------------------|-------------------|-------------------|-------------------|-------------------|-------------------|-------------------|-----------------|
| 500 | 18.00 (427.20) | 10.50 (266.70) | 5.25 (133.35) | 8.50 (215.90) | 4.25 (107.95) | 2.00 (50.80) | 5.50 (139.70) | 7.00 (177.80) | .75 (19.05) | 4.25 (107.95) | 4.19 (106.43) | 9.38 (238.25) | 8.50 (215.90) | 10.62 (269.75) | 5.25 (133.35) | 13.38 (339.85) | 10.75 (273.05) | .406 (10.31) |
| 600 | 19.25 (488.95) | 10.50 (266.70) | 5.25 (133.35) | 8.50 (215.90) | 4.25 (107.95) | 2.00 (50.80) | 6.12 (155.45) | 7.00 (177.80) | .75 (19.05) | 4.25 (107.95) | 5.38 (136.65) | 9.38 (238.25) | 8.50 (215.90) | 10.62 (269.75) | 5.25 (133.35) | 13.38 (339.85) | 10.75 (273.05) | .406 (10.31) |
| 700 | 26.75 (679.45) | 15.75 (400.05) | 7.88 (200.15) | 12.50 (317.50) | 6.25 (158.75) | 3.25 (82.55) | 7.38 (187.45) | 12.00 (304.80) | 1.50 (38.10) | 3.12 (79.25) | 5.78 (146.81) | 12.25 (311.15) | 15.00 (381.00) | 15.19 (385.83) | 8.00 (203.20) | 19.00 (482.60) | 16.38 (416.05) | .656 (16.66) |
| 750 | 28.25 (717.55) | 15.75 (400.05) | 7.88 (200.15) | 12.50 (317.50) | 6.25 (158.75) | 3.25 (82.55) | 8.13 (206.50) | 12.00 (304.80) | 1.50 (38.10) | 3.12 (79.25) | 6.53 (166.81) | 12.25 (311.15) | 15.00 (381.00) | 15.19 (385.83) | 8.00 (203.20) | 19.00 (482.60) | 16.38 (416.05) | .656 (16.66) |
| 800 | 34.00 (863.60) | 19.75 (501.65) | 9.88 (250.95) | 16.00 (406.40) | 8.00 (203.20) | 3.75 (95.25) | 10.12 (257.05) | 13.75 (349.25) | 1.50 (38.10) | 3.50 (88.90) | 8.12 (206.25) | 14.12 (358.65) | 16.75 (425.45) | 17.75 (450.85) | 10.00 (254.00) | 23.25 (590.55) | 20.50 (520.70) | .812 (20.63) |
| 900 | 36.00 (914.50) | 19.75 (501.65) | 9.88 (250.95) | 16.00 (406.40) | 8.00 (203.20) | 3.75 (95.25) | 11.12 (282.45) | 13.75 (349.25) | 1.50 (38.10) | 3.50 (88.90) | 9.12 (231.65) | 14.12 (358.65) | 16.75 (425.45) | 17.75 (450.85) | 10.00 (254.00) | 23.25 (590.55) | 20.50 (520.70) | .812 (20.63) |
| 1027 | 41.00 (1041.40) | 22.00 (558.80) | 11.00 (279.40) | 18.00 (427.20) | 9.00 (228.60) | 4.00 (101.60) | 12.25 (311.15) | 16.50 (419.10) | 1.50 (38.10) | 4.00 (101.60) | 11.00 (279.40) | 15.00 (381.00) | 19.50 (495.30) | 19.00 (482.60) | 11.00 (279.40) | 26.19 (665.23) | 22.25 (565.15) | .812 (20.63) |
| 1051 | 41.00 (1041.40) | 22.00 (558.80) | 11.00 (279.40) | 18.00 (427.20) | 9.00 (228.60) | 4.00 (101.60) | 12.25 (311.15) | 16.50 (419.10) | 1.50 (38.10) | 4.00 (101.60) | 11.00 (279.40) | 15.00 (381.00) | 19.50 (495.30) | 19.00 (482.60) | 11.00 (279.40) | 26.19 (665.23) | 22.25 (565.15) | .812 (20.63) |

| Size | X* Output Shaft Dia. | Y* Input Shaft Dia. | Both Ends | | |
|------|--------------------------------|--------------------------------|--------------------------------|--------------------------------|-------------------------------------|
| | | | K Keyseats | J Usable Shaft Length | H Effective Keyseat Length |
| 500 | 1.437/1.436 (36.49/36.47) | 1.500/1.499 (38.10/38.07) | 3/8 x 3/16 (9.53 x 4.76) | 2.75 (69.85) | 2.50 (63.50) |
| 600 | 1.687/1.686 (42.85/42.82) | 1.750/1.749 (44.45/44.42) | 3/8 x 3/16 (9.53 x 4.76) | 3.38 (85.85) | 3.00 (76.20) |
| 700 | 3.000/2.999 (76.20/76.17) | 3.062/3.061 (77.77/77.75) | 3/4 x 3/8 (19.05 x 9.65) | 4.50 (114.30) | 4.00 (101.60) |
| 750 | 3.000/2.999 (76.20/76.17) | 3.062/3.061 (77.77/77.75) | 3/4 x 3/8 (19.05 x 9.65) | 5.38 (136.65) | 4.75 (120.65) |
| 800 | 3.937/3.936 (100.00/99.97) | 4.000/3.999 (101.60/101.57) | 1 x 1/2 (25.40 x 12.70) | 6.25 (158.75) | 5.00 (127.00) |
| 900 | 3.937/3.936 (100.00/99.97) | 4.000/3.999 (101.60/101.57) | 1 x 1/2 (25.40 x 12.70) | 7.25 (184.15) | 6.00 (152.40) |
| 1027 | 5.376/5.375 (136.53/136.50) | 5.437/5.436 (138.10/138.07) | 1 1/4 x 5/8 (31.75 x 16.00) | 8.63 (219.20) | 7.75 (196.85) |
| 1051 | 5.376/5.375 (136.53/136.50) | 5.437/5.436 (138.10/138.07) | 1 1/4 x 5/8 (31.75 x 16.00) | 8.63 (219.20) | 7.75 (196.85) |

* For C/T models, the input and output shaft diameters are reversed.