

# General Purpose Clutches

## CSK, CSK..2RS

Overrunning, Indexing, Backstopping Bearing Envelope (62 Series) Design, Sprag Clutches



### CSK

Type CSK is a sprag type clutch integrated into a 62 Series ball bearing (except sizes 8 and 40). It is bearing supported, shipped grease lubricated and protected against dust larger than .012" (.3mm) diameter. The use of additional "nylos" type seals is recommended especially when the working temperature exceeds 122°F (50°C).

Oil bath lubrication is also possible if the original grease is first flushed out using a suitable solvent.

Torque transmission is ensured by a press fit assembly into a rigid outer housing with a recommended N6 tolerance and onto a shaft with a recommended n6 tolerance. The resulting housing and shaft diameters must be checked to ensure that the bearing has adequate radial clearances. The initial bearing radial clearance is set at C5, and is reduced if using the press fit as specified.

One race may be glued. If both races are to be glued, performance will be reduced or a C3 bearing clearance will be necessary.

Operating temperature: 21 to 140°F (-6 to 60°C). Special grease available for operating temperatures: -40 to 212°F (-40 to 100°C)

### CSK..2RS

CSK..2RS clutches are .197" (5mm) wider than a standard 62 Series bearing, as they are equipped with lip seals for washdown applications.

### Specifications

Model	Size	Bearing Series	Torque Capacity** lb.ft. (Nm)	Max. Overrunning Speed RPM	Resistance after run-in lb.in. (Ncm)	Lubrication	Shipping Weight lb. (kg)
CSK	8		2.6 (3.5)	15,000	0.04 (0.5)	Grease	0.03 (0.015)
	12	6201	8.8 (12)	10,000	0.06 (0.7)	Grease	0.09 (0.04)
	15	6202	14.7 (20)	8,400	0.08 (0.9)	Grease	0.13 (0.06)
	17	6203	30 (40)	7,350	0.09 (1.1)	Grease	0.15 (0.07)
	20	6204	50 (68)	6,000	0.12 (1.3)	Grease	0.24 (0.11)
	25	6205	77 (105)	5,200	0.18 (2)	Grease	0.31 (0.14)
	30	6206	133 (180)	4,200	0.39 (4.4)	Grease	0.46 (0.21)
	35	6207	177 (240)	3,600	0.51 (5.8)	Grease	0.66 (0.3)
	40		284 (385)	3,000	0.62 (7)	Grease	1.10 (0.5)
	CSK..2RS	8*		2.6 (3.5)	15,000	0.07 (0.8)	Grease
12			8.8 (12)	10,000	0.27 (3)	Grease	0.11 (0.05)
15			14.7 (20)	8,400	0.35 (4)	Grease	0.15 (0.07)
17			30 (40)	7,350	0.50 (5.6)	Grease	0.20 (0.09)
20			50 (68)	6,000	0.53 (6)	Grease	0.32 (0.145)
25			77 (105)	5,200	0.53 (6)	Grease	0.39 (0.175)
30			133 (180)	4,200	0.66 (7.5)	Grease	0.60 (0.27)
35			177 (240)	3,600	0.73 (8.2)	Grease	0.88 (0.4)
40			284 (385)	3,000	0.89 (10)	Grease	1.32 (0.6)

\* Only one lip seal on ball bearing side.

\*\* Clutch torque ratings are based upon 1 million load cycles, standard for the North American market.

# General Purpose Clutches

## CSK, CSK..2RS

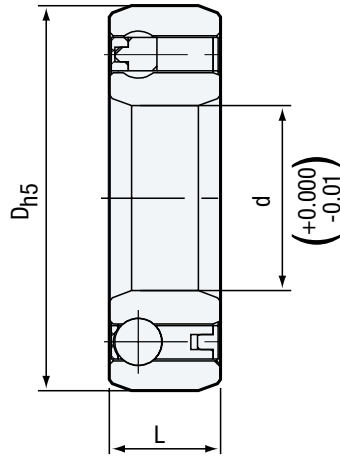

### Dimensions inches (mm)

Model	Size	D <sub>h5</sub> in. (mm)	L in. (mm)	Bearing Loads	
				Dynamic lb. (kN)	Static lb. (kN)
CSK	8	0.87 (22)	0.35 (9)	738 (3.28)	193.5 (0.86)
	12	1.26 (32)	0.39 (10)	1372.5 (6.1)	623.25 (2.77)
	15	1.38 (35)	0.43 (11)	1665 (7.4)	769.5 (3.42)
	17	1.57 (40)	0.47 (12)	1777.5 (7.9)	855 (3.8)
	20	1.85 (47)	0.55 (14)	2115 (9.4)	1003.5 (4.46)
	25	2.05 (52)	0.59 (15)	2407.5 (10.7)	1228.5 (5.46)
	30	2.44 (62)	0.63 (16)	2632.5 (11.7)	1451.25 (6.45)
	35	2.83 (72)	0.67 (17)	2835 (12.6)	1638 (7.28)
	40	3.15 (80)	0.87 (22)	3496.5 (15.54)	2756.25 (12.25)
	CSK..2RS	8*	0.87 (22)	0.35 (9)	738 (3.28)
12		1.26 (32)	0.55 (14)	1372.5 (6.1)	623.25 (2.77)
15		1.38 (35)	0.63 (16)	1665 (7.4)	769.5 (3.42)
17		1.57 (40)	0.67 (17)	1777.5 (7.9)	855 (3.8)
20		1.85 (47)	0.75 (19)	2115 (9.4)	1003.5 (4.46)
25		2.05 (52)	0.79 (20)	2407.5 (10.7)	1228.5 (5.46)
30		2.44 (62)	0.83 (21)	2632.5 (11.7)	1451.25 (6.45)
35		2.83 (72)	0.87 (22)	2835 (12.6)	1638 (7.28)
40		3.15 (80)	1.06 (27)	3496.5 (15.54)	2756.25 (12.25)

\* Only one lip seal on ball bearing side.

### Bore sizes and keyseats inches (mm)

Size	d Bore Size	Keyseat
8	0.31 (8)	None
12	0.47 (12)	None
15	0.59 (15)	None
17	0.67 (17)	None
20	0.79 (20)	None
25	0.98 (25)	None
30	1.18 (30)	None
35	1.38 (35)	None
40	1.57 (40)	None

### Typical Mounting Arrangement

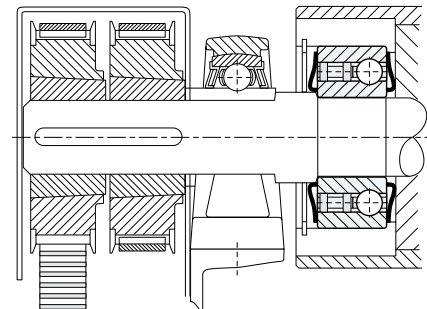

The Model CSK clutches must be mounted with a press fit on both the outer and inner races. The shaft diameter tolerance must be held to a n6. The bore of the housing for the outer race should be a N6 tolerance.