

Special Purpose Clutches

FS 100, 200 and 300

Overrunning, Indexing, Backstopping External Bearing Support Required, Sprag Clutches

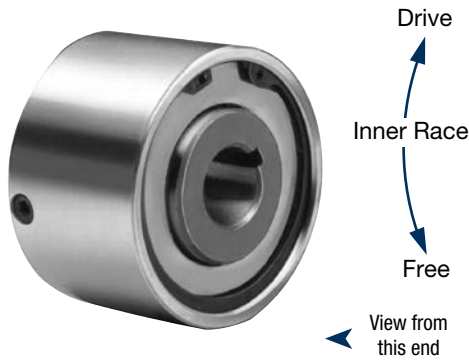

Right Hand rotation shown.
(Left Hand opposite.)

Specify direction of rotation when ordering.

This clutch is intended for application at the end of a shaft. A snap-ring bearing must be inserted before installing. Basically an indexing clutch, it can however be used as an overrunning or backstop clutch. An adequate seal or cover must be provided at the open end to retain lubricant. Shaft end must be turned down and threaded to accommodate bearing and lock nut.

FS 100 through 300 clutches are oil dipped at the factory but *must be filled to the proper level before operation.*

For further information, see *Installation and Maintenance Bulletin No. 2218, P-222-9.*

Specifications

Size	Torque Capacity lb.ft. (Nm)	Overrunning Speed Max. RPM		Power Rating per 100 RPM HP (kw)	Resistance after run-in lb.ft. (Nm)	Shipping Weight lb. (kg)
		Inner Race	Outer Race			
100	70 (95)	1,800	450	1.1 (0.8)	3 (4.0)	1.75 (.79)
200	230 (312)	1,800	450	2.8 (2.1)	7.5 (10.0)	4.5 (2.04)
300	440 (607)	1,200	300	5.5 (4.1)	10 (13.56)	7.75 (3.52)

Typical Mounting Arrangements

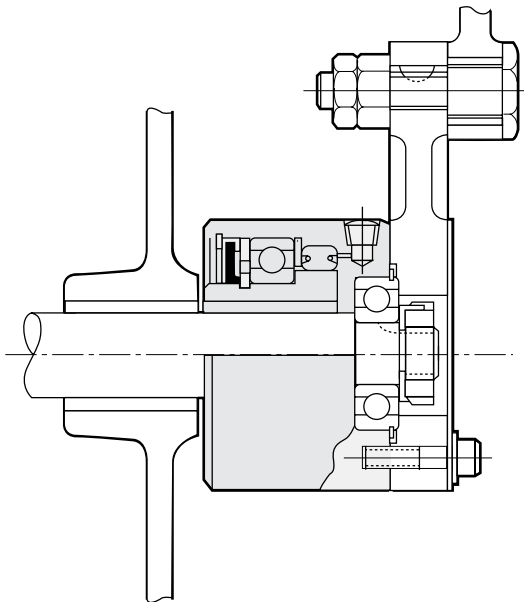

Indexing Clutch

The Model FS clutches require a snap-ring bearing (furnished by customer) mounted in the open end of the clutch as shown. An adequate seal or cover must be provided at the open end to retain lubricant. The shaft end must be turned down or threaded to accommodate the bearing or lock nut. All fasteners are recommended to be grade 8 bolts.

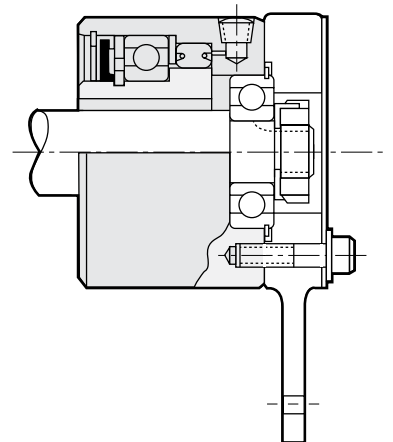

Backstop Clutch

Special Purpose Clutches

FS 100, 200 and 300

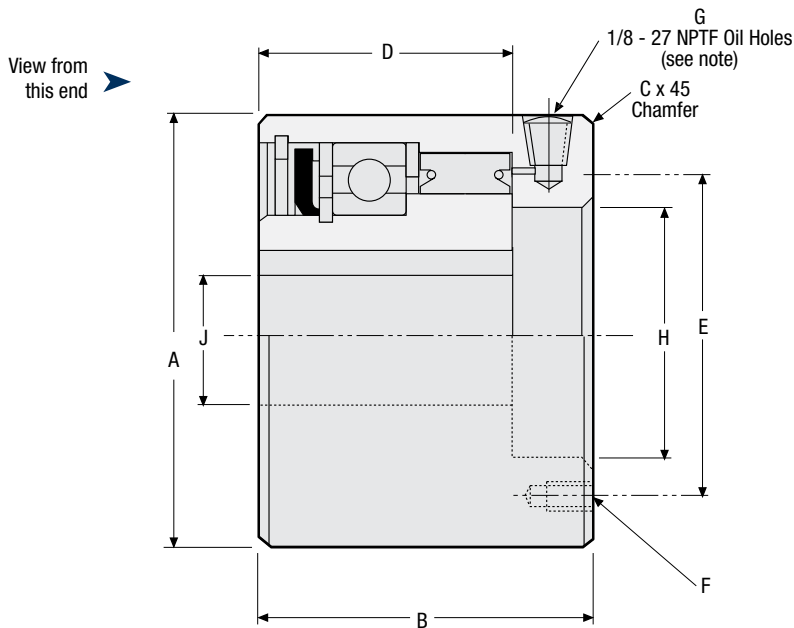

Notes:

Angle — oil hole to mounting bolt hole

Model 100 = 45°

200 = 45°

300 = 30°

Bore sizes and keyseats* inches (mm)

Size	J Bore Size	Keyseat	Bore Range	
			Min.	Max.
100	.500 (12.70)	1/8 x 1/16 (3.18 x 1.59)	.500 (12.70)	.625 (15.88)
	.625 (15.88)	3/16 x 3/32 (4.75 x 2.38)		
	1.00 (25.40)	1/4 x 1/8 (6.35 x 3.18)		
200	1.125 (28.57)	3/8 x 3/16 (9.52 x .475)	1.00 (25.40)	1.313 (33.35)
	1.250 (31.75)			
	1.313 (33.35)			
300	1.00 (25.40)	1/4 x 1/8 (6.35 x 3.18)	1.00 (25.40)	2.00 (50.80)
	1.750 (44.45)	3/8 x 3/16 (9.52 x .475)		
	2.00 (50.80)	1/2 x 1/4 (12.70 x 6.3)		

* For Bore Sizes/Shaft Tolerances, see page 126.

Dimensions inches (mm)

Size	A	B	C	D	E	F			G	Snap Ring Ball Bearing		
						Number	Thread	Depth		Bore H	Bearing No.	Bearing I.D.
100	2.375 (60.3)	2.125 (53.9)	.031 (.79)	1.500 (38.1)	1.875 (47.6)	4	1/4 - 28 NF	.375 (9.52)	2 @ 180°	1.1811/1.1816 (29.9/30.0)	200	.3937 (9.9)
200	3.562 (142.8)	2.281 (57.9)	.031 (.79)	1.687 (42.8)	2.750 (69.8)	4	5/16 - 24 NF	.375 (9.52)	2 @ 180°	2.0470/2.0475 (51.9/52.0)	304	.7874 (19.9)
											205	.9843 (25.0)
300	4.500 (114.3)	2.750 (69.8)	.062 (1.57)	1.937 (49.2)	3.750 (95.2)	6	3/8 - 24 NF	.500 (12.7)	3 @ 120°	2.8345/2.8349 (71.9/72.0)	306	1.1811 (29.9)
											207	1.3780 (35.0)