

Special Purpose Ball Bearing Clutches

HPO

Overrunning, Backstopping Ball Bearing Supported, Sprag Clutch



The HPO series is especially designed for high speed outer race overrunning applications, such as high speed dual drives or standby drives.

HPO clutches are grease lubricated and equipped with labyrinth seals. Formchrome® sprags and special retainers are incorporated for maximum service life and speed capability. These clutches mount on a through shaft, with the inner race driven by a key. The ground O.D. of the outer race is designed as the mounting surface for attaching parts and is concentric with the bore. Tapped holes are provided in each end of the outer race for securing parts to the clutch.

Refer to Bore Sizes/Shaft Tolerance chart for mounting data, page 126.

Standard keys are supplied by Formsprag at no additional charge on models 750, 800, 900 and 1027.

HPO-720 through 1027 clutches are shipped from the factory packed with Fiske Brothers Aero-Lubriplate grease.

For further information see Installation & Maintenance Bulletin No. 2212, P-222-5.

Typical Mounting Arrangement

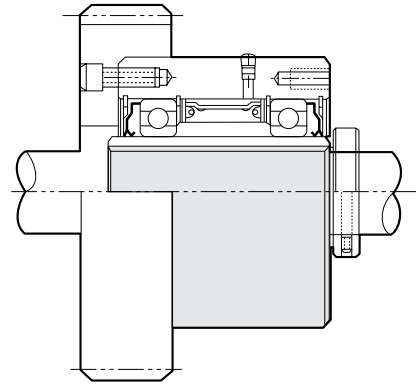

The Model HPO clutches must be axially restrained, see accessories page 120 for set collars, restraint keys and OSHA covers, etc. All fasteners are recommended to be grade 8 bolts.

Specifications

Size	Torque Capacity lb.ft. (Nm)	Overrunning Speed Max. RPM		Resistance after run-in lb.ft. (Nm)	Lubrication (Grease) Required oz. (ml)	Shipping Weight lb. (kg)
		Inner Race	Outer Race			
720	3,200 (4339)	600	3,000	2.75 (3.373)	6.5 (192)	42 (19)
750	4,800 (6508)	525	2,600	3.75 (5.08)	7 (207)	83 (38)
800	8,000 (10848)	475	2,100	5.25 (7.12)	8 (236.5)	102 (46)
900	12,000 (16272)	400	1,850	6.25 (8.47)	18 (532)	156 (71)
1027	18,000 (24408)	300	1,500	10 (13.56)	28 (828)	250 (113)

Notes:

Check key and shaft stress before making final clutch selection since this may determine the maximum allowable drive torque capacity.

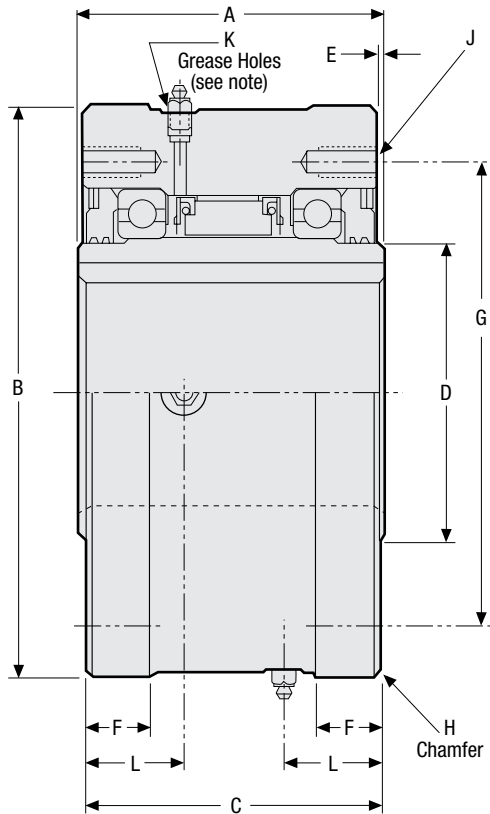

Notes:

- Angle — oil hole to mounting bolt hole
- Model 750 = 0° to 30°
- 800 = 0° to 45°
- 900 = 0° to 18°
- 1027 = 15°

Bore sizes and keyseats* inches (mm)
(Metric bore also available)

Size	Bore Size	Keyseat	Bore Range			
			Min.	Max.		
720	2.00 (50.80)	.500 x .25 (12.70 x 6.35)	1.875	*2.937		
	2.25 (57.15)					
	2.50 (63.50)	.625 x .31 (15.87 x 7.92)	(47.62)	(74.60)		
	2.75 (69.85)	.625 x .22 (15.87 x 5.54)				
750	2.437 (61.90)	.625 x .32 (15.87 x 7.94)	2.250	3.437		
	2.500 (63.50)					
	2.750 (69.85)					
	2.937 (74.60)	.750 x .38 (19.05 x 9.52)	(57.15)	(87.30)		
	3.000 (76.20)					
	3.250 (82.55)					
800	3.437 (87.30)	.750 x .38 (19.05 x 9.52)	2.625	4.437		
	3.500 (88.90)					
	3.750 (95.25)					
	3.937 (100.00)					
	4.000 (101.60)	1.000 x .50 (25.40 x 12.70)	(66.67)	(112.70)		
	4.250 (107.95)					
	4.437 (112.70)					
	4.437 (112.70)					
900	4.000 (101.60)	1.000 x .50 (25.40 x 12.70)	3.625	5.437		
	4.250 (107.95)					
	4.437 (112.70)					
	4.500 (114.30)					
	4.750 (120.65)	1.000 x .38 (25.40 x 9.52)	(92.07)	(138.10)		
	4.937 (125.40)					
	5.000 (127.00)					
	5.250 (133.35)					
1027	5.437 (138.10)	1.000 x 25 (25.40 x 6.35)	4.937	7.000		
	4.937 to 6.000 (125.40 to 152.40)	1.250 x .63 (31.75 x 15.87)			(125.40)	(177.80)
	6.250 to 6.625 (158.75 to 168.27)	1.500 x .50 (38.10 x 12.70)				
	6.750 to 6.875 (171.45 to 174.62)	1.500 x .50 (38.10 x 12.70)				
	7.000 (177.80)	1.500 x .44 (38.10 x 11.10)				

* .625 x .13 keyway

Dimensions inches (mm)

Size	A	B	C	D	E	F	G	H	J			K	L
									Number	Thread	Depth		
720	5.00 (127.00)	7.125/7.123 (180.97/180.92)	4.88 (123.82)	3.56 (90.47)	.06 (1.57)	—	6.25 (158.75)	.06 x 45° (1.57 x 45°)	8*	.375-24	.75 (19.05)	.250-28	2.44 (61.90)
750	6.00 (152.40)	8.750/8.748 (222.25/222.20)	5.88 (149.22)	4.25 (107.95)	.06 (1.57)	1.25 (31.75)	7.00 (177.80)	.06 x 45° (1.57 x 45°)	8*	.500-20	1.00 (25.40)	.500-24	1.94 (49.20)
800	6.00 (152.40)	10.000/9.998 (254.00/253.95)	5.88 (149.22)	5.50 (139.70)	.06 (1.57)	1.25 (31.75)	8.94 (227.00)	.06 x 45° (1.57 x 45°)	8 @ 45°	.500-20	1.00 (25.40)	.500-24	1.94 (49.20)
900	6.38 (161.92)	12.000/11.997 (304.80/304.72)	6.25 (158.75)	6.38 (161.92)	.06 (1.57)	1.38 (34.92)	9.75 (247.65)	.06 x 45° (1.57 x 45°)	10 @ 36°	.625-18	1.25 (31.75)	.500-20	2.13 (53.97)
1027	6.63 (168.27)	15.000/14.997 (381.00/380.92)	6.50 (165.10)	9.00 (228.60)	.06 (1.57)	1.38 (34.92)	11.75 (298.45)	.13 x 45° (3.17 x 45°)	12 @ 30°	.625-18	1.00 (25.40)	.500-20	2.13 (53.97)

* Six holes equally spaced at 60° plus two extra holes at 180°. Six hardened mounting screws are adequate for torque loads up to 3000 lb. ft. (4068 Nm) for model 720. Use eight hardened mounting screws for torque loads above these values. On model 750, six hardened mounting screws are adequate to handle torque rating.