

# Clutch Couplings

## RIZ..ELG2

### Overrunning Ball Bearing Supported, Centrifugal Throw-out (C/T) Sprag Clutch Couplings

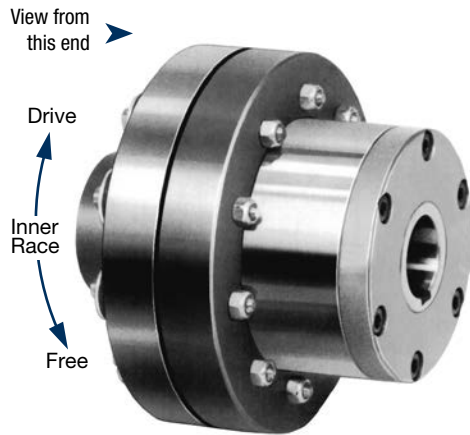

Model RIZ..ELG2 is a centrifugal throw-out sprag clutch with a coupling for in-line shaft mounting applications. In this design only the inner race can overrun.

They are self-contained units designed for overrunning clutch applications. Typically used in creep drives, where the overrunning speed is high, but the drive speed low, and does not exceed the maximum driving speed specified in the table.

When ordered complete, the unit is shipped grease lubricated, ready for either horizontal or vertical installation.

*Right Hand rotation shown.  
(Left Hand opposite.)*

*Specify direction of rotation when ordering.*

### Specifications

Size	EL	Torque Capacity lb.ft. (Nm)	Overrunning Speed Max. RPM			Lubrication	Shipping Weight lb. (kg)
			Drive	Sprag Lift-off	Overrunning		
30	5	231 (313)	350	780	9,000	Grease	24.26 (11)
35	6	277 (375)	320	740	8,500	Grease	37.48 (17)
40	6	576 (781)	315	720	7,500	Grease	41.90 (19)
45	6	660 (894)	285	665	6,600	Grease	41.90 (19)
50	7	1,033 (1400)	265	610	6,000	Grease	68.36 (31)
60	8	1,384 (1875)	200	490	5,300	Grease	108.05 (49)
70	10	2,077 (2815)	210	480	4,100	Grease	198.45 (90)
80	11	3,321 (4500)	190	450	3,600	Grease	235.94 (107)
90	12	4,244 (5750)	180	420	2,700	Grease	374.85 (170)
100	14	7,011 (9500)	200	455	2,700	Grease	507.15 (230)
130	16	12,454 (16875)	180	415	2,400	Grease	727.65 (330)

**Note:** When ordering, please specify direction of rotation.

### RIZ..ELG2

View from  
this end 

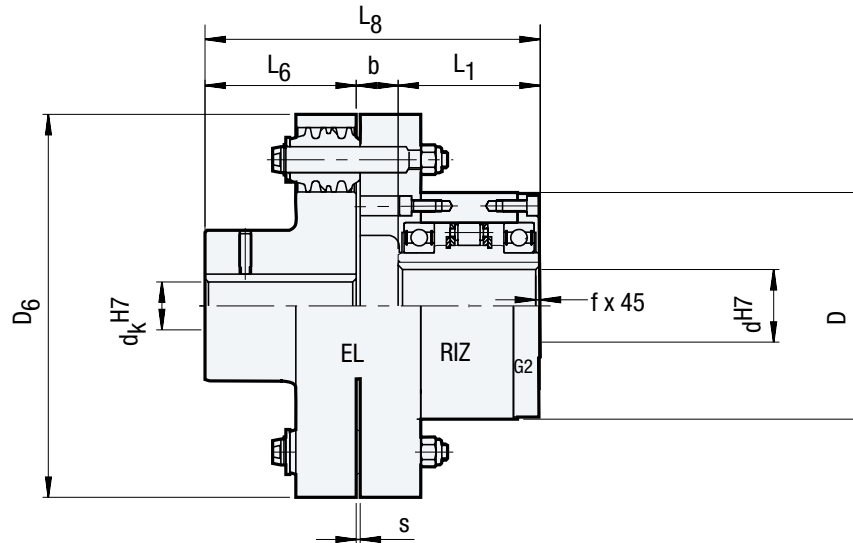

### Dimensions inches (mm)

Size	d <sup>H7</sup>	d <sub>k</sub> <sup>H7</sup> Bore Range	D	L <sub>1</sub>	D <sub>6</sub>	L <sub>6</sub>	L <sub>8</sub>	b	s	f
30	1.18 (30)	0.79 – 2.17 (20 – 55)	3.94 (100)	2.68 (68)	6.30 (160)	2.36 (60)	5.81 (147.5)	0.77 (19.5)	0.08 (2)	0.04 (1)
35	1.38 (35)	0.98 – 2.95 (25 – 75)	4.33 (110)	2.91 (74)	7.48 (190)	2.95 (75)	6.56 (166.5)	0.69 (17.5)	0.08 (2)	0.04 (1)
40	1.57 (40)	0.98 – 2.95 (25 – 75)	4.92 (125)	3.39 (86)	7.48 (190)	2.95 (75)	6.95 (176.5)	0.61 (15.5)	0.08 (2)	0.06 (1.5)
45	1.77 (45)	0.98 – 2.95 (25 – 75)	5.12 (130)	3.39 (86)	7.48 (190)	2.95 (75)	6.95 (176.5)	0.61 (15.5)	0.08 (2)	0.06 (1.5)
50	1.97 (50)	1.18 – 3.35 (30 – 85)	5.91 (150)	3.70 (94)	8.86 (225)	3.54 (90)	8.21 (208.5)	0.96 (24.5)	0.10 (2.5)	0.06 (1.5)
60	2.36 (60)	1.38 – 3.94 (35 – 100)	6.69 (170)	4.49 (114)	10.63 (270)	3.94 (100)	9.61 (244)	1.18 (30)	0.12 (3)	0.08 (2)
70	2.76 (70)	1.77 – 4.72 (45 – 120)	7.48 (190)	5.28 (134)	13.39 (340)	5.51 (140)	12.30 (312.5)	1.52 (38.5)	0.12 (3)	0.10 (2.5)
80	3.15 (80)	2.17 – 5.71 (55 – 145)	8.27 (210)	5.67 (144)	14.96 (380)	6.30 (160)	13.39 (340)	1.42 (36)	0.12 (3)	0.10 (2.5)
90	3.54 (90)	2.56 – 6.50 (65 – 165)	9.06 (230)	6.22 (158)	17.32 (440)	7.09 (180)	15.28 (388)	1.97 (50)	0.14 (3.5)	0.12 (3)
100	3.94 (100)	2.95 – 6.69 (75 – 170)	10.63 (270)	7.17 (182)	19.69 (500)	7.87 (200)	16.63 (422.5)	1.59 (40.5)	0.14 (3.5)	0.12 (3)
130	5.12 (130)	3.35 – 7.09 (85 – 180)	12.20 (310)	8.35 (212)	22.05 (560)	8.66 (220)	18.98 (482)	1.97 (50)	0.16 (4)	0.12 (3)

**Note:** For clutch bore and keyseat information see page 103.