

General Purpose Clutches

RSCI

Overrunning, Backstopping External Bearing Support Required, Centrifugal Throw-out (C/T) Sprag Clutches



Model RSCI is a centrifugal throwout sprag type overrunning clutch with the inner race rotating. Only the inner race is designed for overrunning.

The RSCI is not a self-supported design. Bearings must be provided to ensure concentricity of the inner and outer races and to support axial and radial loads. Concentricity and run-out limits must be observed.

Primarily designed as a backstop, this model can also be used as an overrunning clutch in creep drives, where the overrunning speed is high, but the driving speed is low, and does not exceed the maximum driving speed shown in the table.

When used as a backstop, it must be checked that the overrunning speed will not go below the sprag lift-off speed given in the specifications table.

The model RSCI has a special sprag design that will work with all types of lubricants including those with EP additives. This sprag design feature allows for clutch usage inside gearboxes without separate lubrication.

If lubricants with EP additives are used, the concentricity tolerance should be reduced by one half.

An oil mist is generally sufficient. Grease lubrication may be acceptable if the unit operates mostly in the overrunning condition, as in electric motors.

Centering of the outer race must be based on the inner race bore, not the sprag cage.

Optional F8 cover must be ordered separately.

For bolt tightening torque values, see page 132.

Specifications

Size	Torque Capacity lb.ft. (Nm)	Speeds (RPM)			Shipping Weight lb. (kg)
		Max. Drive	Sprag Lift-Off	Max. Inner Race Overrunning	
20	156 (212)	315	750	15,000	3.31 (1.5)
25	235 (319)	300	725	14,000	3.53 (1.6)
30	277 (375)	290	700	11,000	3.97 (1.8)
35	406 (550)	280	670	11,000	4.63 (2.1)
40	590 (800)	260	630	8,000	5.95 (2.7)
45	673 (912)	255	610	7,000	6.39 (2.9)
50	1,033 (1400)	235	560	6,000	9.48 (4.3)
60	1734 (2350)	210	510	6,000	14.33 (6.5)
70	2,250 (3050)	195	470	4,000	18.96 (8.6)
80	3,321 (4500)	180	440	4,000	27.56 (12.5)
80M	4,264 (5800)	155	375	4,000	29 (13.1)
90	3,595 (5600)	170	410	3,000	38.37 (17.4)
90M	6,420 (8700)	145	350	3,000	40.3 (18.3)
100	7,749 (10500)	145	355	3,000	62.0 (28)
100M	11,808 (16000)	140	340	2,400	66 (30)
130	11,623 (15750)	135	330	2,400	77.18 (35)
180	23,247 (31500)	115	285	1,300	134 (61)
180M	36,900 (50000)	90	220	1,300	202 (92)
180-II	46,494 (63000)	115	285	1,300	260 (118)

Notes:

Keyway to DIN 6885.1

Typical Mounting Arrangement

The Model RSCI must be mounted next to a bearing to provide the inner race to outer race concentricity and support any radial or axial loads. This clutch must be enclosed and coated with a film of grease or oil mist.

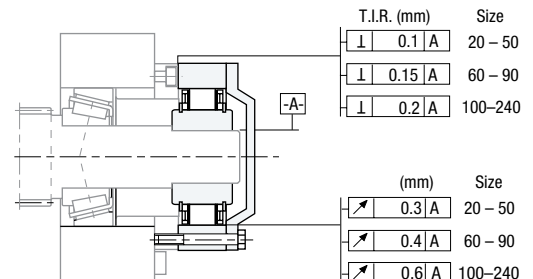

RSCI 20-180

F8

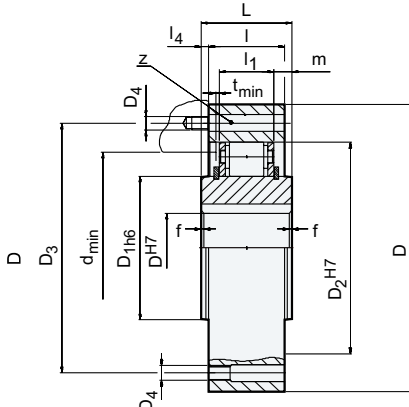

Dimensions inches (mm)

Size	D	D _{1H6}	D _{2H7}	D ₃	D ₄	Z # of holes	L	l	l ₁	l ₄	f x 45°	d _{min.}	m	t _{min.}	l ₂	l ₃
20	3.54 (90)	1.42 (36)	2.60 (66)	3.07 (78)	M6	6	1.38 (35)	1.38 (35)	0.98 (25)	0	0.03 (0.8)	2.05 (52)	0.20 (5)	0.04 (1)	0.31 (8)	0.63 (16)
25	3.74 (95)	1.57 (40)	2.76 (70)	3.23 (82)	M6	6	1.38 (35)	1.38 (35)	0.98 (25)	0	0.04 (1)	2.20 (56)	0.20 (5)	0.04 (1)	0.31 (8)	0.63 (16)
30	3.94 (100)	1.77 (45)	2.95 (75)	3.43 (87)	M6	6	1.38 (35)	1.38 (35)	0.98 (25)	0	0.06 (1.5)	2.44 (62)	0.20 (5)	0.04 (1)	0.31 (8)	0.63 (16)
35	4.33 (110)	1.97 (50)	3.15 (80)	3.78 (96)	M6	8	1.38 (35)	1.38 (35)	0.98 (25)	0	0.06 (1.5)	2.60 (66)	0.20 (5)	0.04 (1)	0.31 (8)	0.63 (16)
40	4.92 (125)	2.36 (60)	3.54 (90)	4.25 (108)	M8	8	1.38 (35)	1.38 (35)	0.98 (25)	0	0.06 (1.5)	2.99 (76)	0.20 (5)	0.04 (1)	0.39 (10)	0.83 (21)
45	5.12 (130)	2.56 (65)	3.74 (95)	4.41 (112)	M8	8	1.38 (35)	1.38 (35)	0.98 (25)	0	0.06 (1.5)	3.23 (82)	0.20 (5)	0.04 (1)	0.39 (10)	0.83 (21)
50	5.91 (150)	3.15 (80)	4.33 (110)	5.20 (132)	M8	8	1.57 (40)	1.57 (40)	0.98 (25)	0	0.06 (1.5)	3.94 (100)	0.30 (7.5)	0.04 (1)	0.39 (10)	0.83 (21)
60	6.89 (175)	3.35 (85)	4.92 (125)	6.10 (155)	M10	8	2.36 (60)	1.97 (50)	1.42 (36)	0.20 (5)	0.08 (2)	4.33 (110)	0.47 (12)	0.08 (2)	0.47 (12)	1.38 (35)
70	7.48 (190)	3.74 (100)	5.51 (140)	6.50 (165)	M10	12	2.36 (60)	1.97 (50)	1.42 (36)	0.20 (5)	0.08 (2)	4.72 (120)	0.47 (12)	0.08 (2)	0.47 (12)	1.38 (35)
80	8.27 (210)	4.53 (120)	6.30 (160)	7.28 (185)	M10	12	2.76 (70)	2.36 (60)	1.42 (36)	0.20 (5)	0.08 (2)	5.51 (140)	0.67 (17)	0.12 (3)	0.47 (12)	1.38 (35)
80M	8.27 (210)	4.72 (120)	6.30 (160)	7.28 (185)	M10	12	2.76 (70)	2.36 (60)	1.81 (46)	0.20 (5)	0.08 (2)	5.51 (140)	0.47 (12)	0.08 (2)	0.47 (12)	1.38 (35)
90	9.06 (230)	5.51 (140)	7.09 (180)	8.11 (206)	M12	12	3.15 (80)	2.76 (70)	1.42 (36)	0.20 (5)	0.10 (2.5)	6.30 (160)	0.87 (22)	0.12 (3)	0.47 (12)	1.38 (35)
90M	9.65 (245)	5.51 (140)	7.09 (180)	8.11 (206)	M12	12	3.15 (80)	2.76 (70)	1.81 (46)	0.20 (5)	0.10 (3)	6.30 (160)	0.67 (17)	0.08 (2)	0.47 (12)	1.38 (35)
100	11.42 (290)	5.51 (140)	8.27 (210)	10.15 (258)	M16	12	3.54 (90)	3.15 (80)	2.07 (52.6)	0.20 (5)	0.10 (2.5)	7.09 (180)	0.73 (18.6)	0.12 (3)	0.59 (15)	1.46 (37)
100M	11.42 (290)	6.69 (170)	8.27 (210)	10.16 (258)	M16	12	3.54 (90)	3.15 (80)	2.48 (63)	0.20 (5)	0.10 (3)	7.87 (200)	0.53 (14)	0.08 (2)	0.47 (12)	1.38 (35)
130	12.68 (322)	6.69 (170)	9.45 (240)	10.94 (278)	M16	12	3.54 (90)	3.15 (80)	2.07 (52.6)	0.20 (5)	0.12 (3)	8.27 (210)	0.73 (18.6)	0.12 (3)	0.59 (15)	1.46 (37)
180	16.22 (412)	— (240)	12.20 (310)	14.17 (360)	M20	12	3.54 (90)	3.15 (80)	2.07 (52.6)	0.20 (5)	0.14 (3.5)	11.02 (280)	0.73 (18.6)	0.12 (3)	0.71 (18)	1.73 (44)
180M	16.61 (422)	9.45 (240)	12.20 (310)	14.57 (370)	M20	18	4.72 (120)	4.72 (120)	3.27 (83)	0 (0)	0.16 (4)	11.02 (280)	0.73 (19)	0.08 (2)		
180-II	16.22 (412)	— (240)	12.20 (310)	14.17 (360)	M20	24	6.30 (160)	3.15 (80)	4.64 (118)	0 (0)	0.14 (3.5)	11.81 (280)	0.83 (21)	0.12 (3)	0.71 (18)	1.73 (44)

Note:

F8 cover must be ordered separately.

* Clearance mounting holes for listed bolt sizes.

** Two extra tapped removal holes @ 180°.

Bore sizes and keyseats
inches (mm)

Size	d ^{H7} Bore Size	Keyseat*
20	0.79 (20)	(6 X 2.8)
25	0.98 (25)	(8 X 3.3)
30	1.18 (30)	(8 X 3.3)
35	1.38 (35)	(10 X 3.3)
40	1.57 (40)	(12 X 3.3)
45	1.77 (45)	(14X 3.8)
50	1.97 (50)	(14X 3.8)
60	2.36 (60)	(18 X 4.4)
70	2.76 (70)	(20 X 4.9)
80	3.15 (80)	(22 X 5.4)
80M	3.15 (80)	(22 x 5.4)
90	3.54 (90)	(25 X 5.4)
90M	3.54 (90)	(25 X 5.4)
100	3.94 (100)	(28 X 6.4)
100M	3.94 (100)	(28 X 6.4)
130	5.12 (130)	(32 X 7.4)
180	7.08 (180)	(1)
180M	7.08 (180)	(1)
180-II	7.08 (180)	(1)

* For keyseat sizes see DIN 6885.1 table on page 127.

General Purpose Clutches

RSCI

Overrunning, Backstopping External Bearing Support Required, Centrifugal Throw-out (C/T) Sprag Clutches



Model RSCI is a centrifugal throwout sprag type overrunning clutch with the inner race rotating. Only the inner race is designed for overrunning.

The RSCI is not a self-supported design. Bearings must be provided to ensure concentricity of the inner and outer races and to support axial and radial loads. Concentricity and run-out limits must be observed.

Primarily designed as a backstop, this model can also be used as an overrunning clutch in creep drives, where the overrunning speed is high, but the driving speed is low, and does not exceed the maximum driving speed shown in the table.

When used as a backstop, it must be checked that the overrunning speed will not go below the sprag lift-off speed given in the specifications table.

The model RSCI has a special sprag design that will work with all types of lubricants including those with EP additives. This sprag design feature allows for clutch usage inside gearboxes without separate lubrication.

If lubricants with EP additives are used, the concentricity tolerance should be reduced by one half.

An oil mist is generally sufficient. Grease lubrication may be acceptable if the unit operates mostly in the overrunning condition, as in electric motors.

Centering of the outer race must be based on the inner race bore, not the sprag cage.

Optional F8 cover must be ordered separately.

For bolt tightening torque values, see page 132.

Specifications

Size	Torque Capacity lb.ft. (Nm)	Speeds (RPM)			Shipping Weight lb. (kg)
		Max. Drive	Sprag Lift-off	Max. Inner Race Overrunning	
180 II-M	73,800 (100000)	90	220	1,300	418 (190)
220	34,133 (42500)	110	265	1,100	194.04 (88)
220M	50,184 (68000)	85	205	1,100	240 (109)
220-II	70,849 (85000)	110	265	1,100	350 (159)
220 II-M	100,368 (136000)	85	205	1,100	548 (249)
240	38,376 (52000)	105	250	1,100	209 (95)
240M	61,254 (83000)	80	195	1,100	301 (137)
240 II	76,752 (104000)	105	250	1,100	420 (191)
240 II-M	122,508 (166000)	80	195	1,100	551 (250)
260	47,970 (65000)	100	240	1,000	286 (130)
260M	73,800 (100000)	75	185	1,000	403 (183)
260 II	95,940 (130000)	100	240	1,000	576 (262)
260 II-M	147,600 (200000)	75	185	1,000	812 (369)
300	57,564 (78000)	90	225	1,000	383 (174)
300M	92,250 (125000)	70	175	1,000	462 (210)
300 II	115,128 (156000)	90	225	1,000	772 (351)
300 II-M	184,500 (250000)	70	175	1,000	1007 (457)

Notes:

Keyway to DIN 6885.1

RSCI 180-300

F8

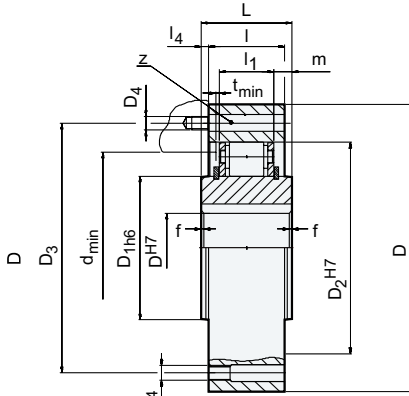

Dimensions inches (mm)

Size	D	D _{1H6}	D _{2H7}	D ₃	D ₄	Z # of holes	L	I	I ₁	I ₄	f x 45°	d _{min.}	m	t _{min.}	l ₂	l ₃
180 II-M	16.73 (425)	9.45 (240)	12.20 (310)	14.57 (370)	M24	24	9.45 (240)	9.45 (240)	6.93 (176)	0 (0)	0.16 (4)	11.02 (280)	1.26 (32)	0.12 (3)		
220	18.50 (470)	— (290)	14.17 (360)	16.14 (410)	M20	16	4.13 (105)	3.15 (80)	2.31 (58.6)	0.20 (5)	0.16 (4)	12.99 (330)	0.77 (19.5)	0.12 (3)	0.71 (18)	2.64 (67)
220M	18.90 (480)	11.42 (290)	14.17 (360)	16.14 (410)	M24	16	4.72 (120)	4.72 (120)	3.27 (83)	0 (0)	0.16 (4)	12.99 (330)	0.73 (19)	0.08 (2)		
220-II	18.89 (480)	— (290)	14.17 (360)	16.14 (410)	M24	18	6.30 (160)	6.30 (160)	5.12 (130)	0 (0)	0.16 (4)	14.17 (330)	0.59 (15)	0.12 (3)	0.71 (18)	2.64 (67)
220 II-M	19.29 (490)	11.42 (290)	14.17 (360)	16.73 (425)	M30	20	9.45 (240)	9.45 (240)	6.93 (176)	0 (0)	0.16 (4)	12.99 (330)	1.26 (32)	0.08 (2)		
240	19.69 (500)	12.60 (320)	15.35 (390)	17.32 (440)	M20	16	4.13 (105)	3.54 (90)	2.36 (60)	0.30 (8)	0.16 (4)	14.17 (360)	0.59 (15)	0.08 (2)		
240M	20.47 (520)	12.60 (320)	15.35 (390)	17.32 (440)	M24	16	4.72 (120)	4.72 (120)	3.27 (83)	0 (0)	0.16 (4)	14.17 (360)	0.73 (19)	0.08 (2)		
240 II	19.88 (505)	12.60 (320)	15.35 (390)	17.32 (440)	M24	24	7.09 (180)	7.09 (180)	5.20 (132)	0 (0)	0.16 (4)	14.17 (360)	0.94 (24)	0.08 (2)		
240 II-M	20.87 (530)	12.60 (320)	15.35 (390)	17.32 (440)	M30	24	9.45 (240)	9.45 (240)	6.93 (176)	0 (0)	0.16 (4)	14.17 (360)	1.26 (32)	0.08 (2)		
260	21.65 (550)	14.17 (360)	16.93 (430)	19.69 (500)	M24	16	4.13 (105)	4.13 (105)	2.36 (60)	0 (0)	0.16 (4)	15.75 (400)	0.89 (23)	0.08 (2)		
260M	22.83 (580)	14.17 (360)	16.93 (430)	19.69 (500)	M24	24	4.92 (125)	4.92 (125)	3.27 (83)	0 (0)	0.16 (4)	15.75 (400)	0.83 (21)	0.08 (2)		
260 II	21.65 (550)	14.17 (360)	16.93 (430)	19.69 (500)	M24	24	8.27 (210)	8.27 (210)	5.20 (132)	0 (0)	0.16 (4)	15.75 (400)	1.54 (39)	0.08 (2)		
260 II-M	22.83 (580)	14.17 (360)	16.93 (430)	19.69 (500)	M30	24	9.84 (250)	9.84 (250)	6.93 (176)	0 (0)	0.16 (4)	15.75 (400)	1.46 (37)	0.08 (2)		
300	24.80 (630)	16.14 (410)	18.90 (480)	22.05 (560)	M24	24	4.13 (105)	4.13 (105)	2.36 (60)	0 (0)	0.16 (4)	18.11 (460)	0.89 (23)	0.12 (3)		
300M	24.80 (630)	16.14 (410)	18.90 (480)	22.05 (560)	M24	24	4.92 (125)	4.92 (125)	3.27 (83)	0 (0)	0.16 (4)	18.11 (460)	0.83 (21)	0.12 (3)		
300 II	24.80 (630)	16.14 (410)	18.90 (480)	22.05 (560)	M24	24	8.27 (210)	8.27 (210)	5.28 (134)	0 (0)	0.16 (4)	18.11 (460)	1.50 (38)	0.12 (3)		
300 II-M	24.80 (630)	16.14 (410)	18.90 (480)	22.05 (560)	M30	24	9.84 (250)	9.84 (250)	7.19 (182.6)	0 (0)	0.16 (4)	18.11 (460)	1.32 (33.7)	0.12 (3)		

Note:

F8 cover must be ordered separately.

* Clearance mounting holes for listed bolt sizes.

** Two extra tapped removal holes @ 180°.

Bore sizes and keyseats
inches (mm)

Size	d ^{H7} Bore Size	Keyseat*
180 II-M	7.08 (180)	(1)
220	8.66 (220)	(1)
220M	8.66 (220)	(1)
220 II	8.66 (220)	(1)
220 II-M	8.66 (220)	(1)
240	9.45 (240)	(1)
240M	9.45 (240)	(1)
240 II	9.45 (240)	(1)
240 II-M	9.45 (240)	(1)
260	10.23 (260)	(1)
260M	10.23 (260)	(1)
260 II	10.23 (260)	(1)
260 II-M	10.23 (260)	(1)
300	11.81 (300)	(1)
300M	11.81 (300)	(1)
300 II	11.81 (300)	(1)
300 II-M	11.81 (300)	(1)

* Keyseat information available on request.