

General Purpose Clutches

AS

Overrunning, Indexing, Backstopping External Bearing Support Required, Ramp & Roller Clutches



Model AS is a ramp & roller type clutch, non-bearing supported.

Bearings are required to support axial and radial loads. Lubrication and sealing are required.

Nominal outside dimensions are the same as Series 62 ball bearings.

A typical arrangement is to install this type alongside a Series 62 bearing, within the same location tolerances.

The inner race is keyed to the shaft (except for size 6 mm bore).

The outer race has a positive r6 tolerance to give a press fit in a H7 housing.

The outer housing must be strong enough not to expand after assembly.

This design can accept an axial misalignment of inner and outer race of $\pm S/2$.

These clutches are oil dipped at the factory but must be filled to the proper level before operation.

This clutch is designed for oil lubrication. For grease lubrication, reduce the maximum overrunning speed to 50% of listed value.

Specifications

Size	Torque Capacity lb.ft. (Nm)	Overrunning Speed Max. RPM		Resistance after run-in lb.in. (Ncm)	Shipping Weight lb. (kg)
		Inner Race	Outer Race		
6	1.5 (2.1)	5,000	7,500	0.02 (0.18)	0.02 (0.01)
8	3 (3.8)	4,300	6,500	0.02 (0.24)	0.04 (0.02)
10	5 (6.8)	3,500	5,200	0.02 (0.69)	0.07 (0.03)
12	10 (13.0)	3,200	4,800	0.04 (0.48)	0.09 (0.04)
15	10 (14.0)	2,800	4,300	0.06 (0.7)	0.11 (0.05)
20	30 (40.0)	2,200	3,300	0.12 (1.4)	0.26 (0.12)
25	41 (56)	1,900	2,900	0.21 (2.4)	0.31 (0.14)
30	66 (90)	1,600	2,400	0.69 (7.8)	0.49 (0.22)
35	106 (143)	1,300	2,000	0.80 (9)	0.68 (0.31)
40	137 (185)	1,200	1,800	0.89 (10)	0.86 (0.39)
45	161 (218)	1,000	1,600	0.97 (11)	0.97 (0.44)
50	170 (230)	950	1,500	1.20 (13)	1.08 (0.49)
55	227 (308)	800	1,300	1.20 (14)	1.46 (0.66)
60	375 (508)	700	1,100	2.30 (26)	1.79 (0.81)
80	784 (1063)	600	900	5.10 (58)	3.11 (1.41)

Typical Mounting Arrangement

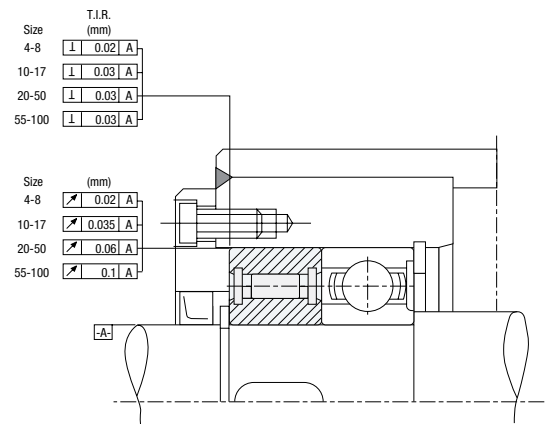

The AS clutch must be mounted adjacent to bearings to provide the concentricity and to support any axial and radial loads. Oil or grease lubrication must be provided along with seals to retain the lubricant.

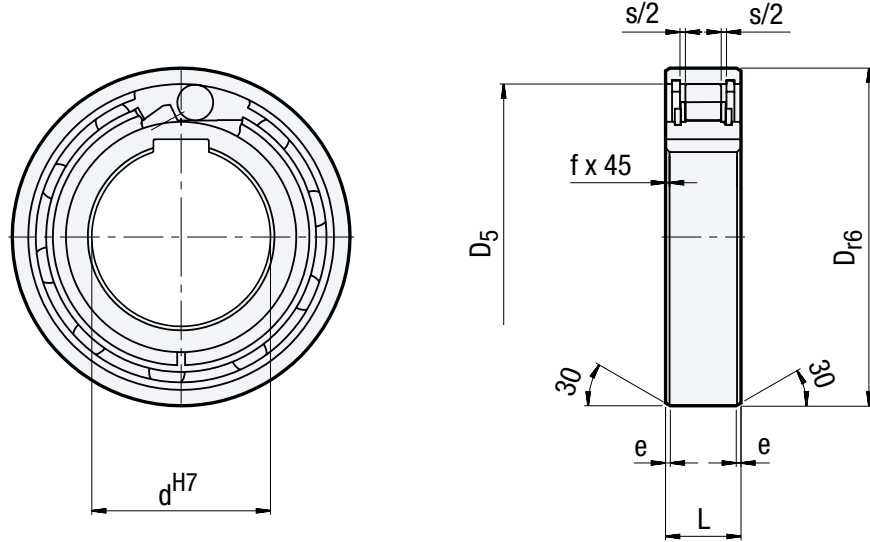

Dimensions inches (mm)

Size	D _{r6}	D ₅	L	s	e	f
6	0.75 (19)	0.62 (15.8)	0.24 (6)	0.03 (0.8)	0.02 (0.6)	0.01 (0.3)
8	0.94 (24)	0.79 (20)	0.31 (8)	0.05 (1.3)	0.02 (0.6)	0.02 (0.6)
10	1.18 (30)	1.02 (25.9)	0.35 (9)	0.05 (1.3)	0.02 (0.6)	0.02 (0.6)
12	1.26 (32)	1.10 (28)	0.39 (10)	0.05 (1.3)	0.02 (0.6)	0.02 (0.6)
15	1.38 (35)	1.22 (31)	0.43 (11)	0.06 (1.4)	0.02 (0.6)	0.02 (0.6)
20	1.85 (47)	1.57 (40)	0.55 (14)	0.09 (2.4)	0.03 (0.8)	0.03 (0.8)
25	2.05 (52)	1.81 (45.9)	0.59 (15)	0.09 (2.4)	0.03 (0.8)	0.03 (0.8)
30	2.44 (62)	2.17 (55)	0.63 (16)	0.09 (2.4)	0.03 (0.8)	0.04 (1)
35	2.83 (72)	2.52 (64)	0.67 (17)	0.10 (2.5)	0.03 (0.8)	0.04 (1)
40	3.15 (80)	2.83 (72)	0.71 (18)	0.10 (2.5)	0.03 (0.8)	0.04 (1)
45	3.35 (85)	3.03 (77)	0.75 (19)	0.10 (2.5)	0.05 (1.2)	0.04 (1)
50	3.54 (90)	3.23 (82)	0.79 (20)	0.10 (2.5)	0.05 (1.2)	0.04 (1)
55	3.94 (100)	3.54 (90)	0.83 (21)	0.10 (2.5)	0.05 (1.2)	0.04 (1)
60	4.33 (110)	3.94 (100)	0.87 (22)	0.10 (2.5)	0.05 (1.2)	0.06 (1.5)
80	5.51 (140)	5.04 (128)	1.02 (26)	0.10 (2.5)	0.05 (1.2)	0.06 (1.5)

Notes:

Mounting dimensions are identical to ball bearings Series 62.

Bore sizes and keyseats inches (mm)

Size	d ^{H7} Bore Size	Keyseat*
6	0.24 (6)	None
8	0.31 (8)	(2 X 1)
10	0.39 (10)	(3 X 1.4)
12	0.47 (12)	(4 X 1.8)
15	0.59 (15)	(5 X 1.2)
20	0.79 (20)	(6 X 1.6)
25	0.98 (25)	(8 X 2)
30	1.18 (30)	(8 X 2)
35	1.38 (35)	(10 X 2.4)
40	1.57 (40)	(12 X 2.2)
45	1.77 (45)	(14 X 2.1)
50	1.97 (50)	(14 X 2.1)
55	2.17 (55)	(16 X 2.4)
60	2.36 (60)	(18 X 2.3)
80	3.15 (80)	(22 X 3.1)

Notes:

* AS6 without keyway. AS8-12 keyway to DIN 6885.1. Other sizes to DIN 6885.3 on page 129.