

BULLETIN A-3037

P-222-32

Installation Instructions

Backstop Clutches

Models FB



23601 Hoover Road - Warren, MI 48089-3994 - 586-758-5000

www.formsprag.com

Introduction

Formsprag model FB Backstops combine a CSK sprag clutch having its own ball bearing with integral seals, a torque arm housing, stub shaft adapter (stub shaft) and clamping assembly (C-Ring Assembly). This design prevents reverse rotation of shafts in applications with large shafts and low back stopping torque requirements. Clutches are selected by torque capacity and shaft size.

⚠ WARNING Failure to follow these instructions may result in product damage, equipment damage, and serious or fatal injury to personnel.

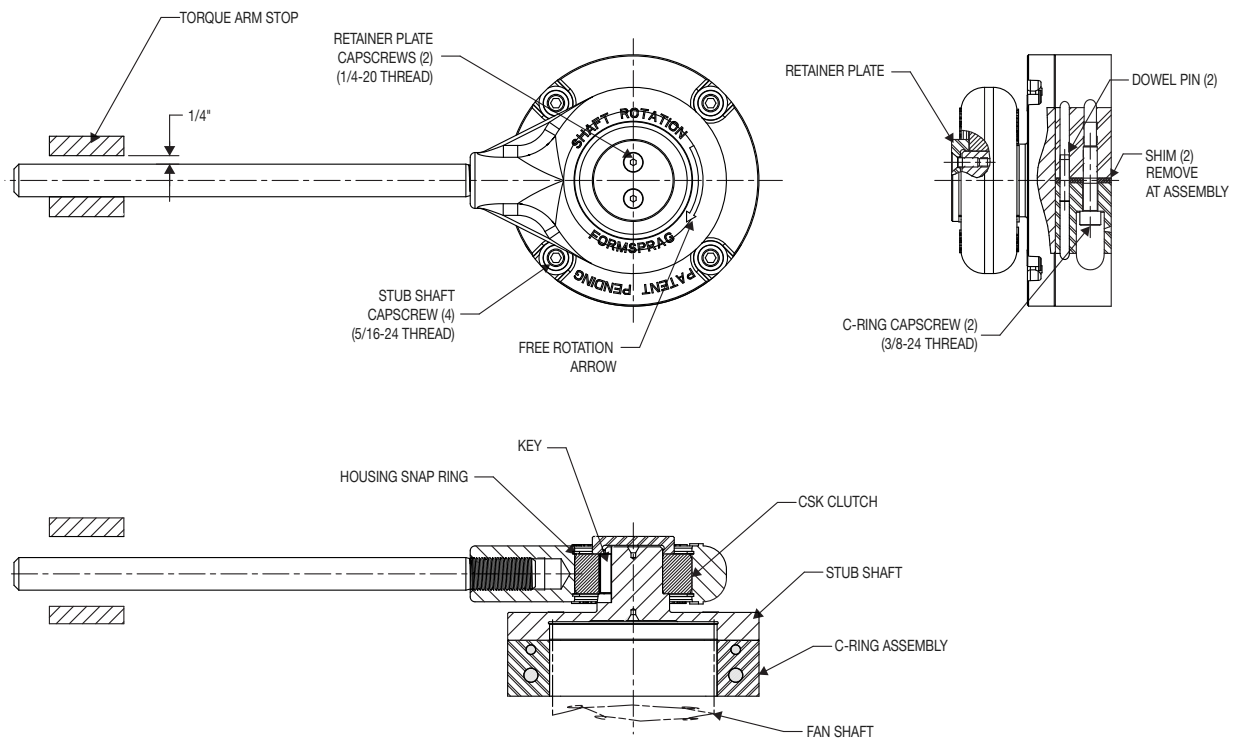

Figure 1

Pre-Installation Instructions

Review Figure 1 to identify the nomenclature for the various components of the model FB Backstop. Remove the retainer plate from the stub shaft adapter by removing the 1/4-20 flat head screws. Slide the backstop housing off the stub shaft adapter. Retain the key and screws for later reassembly.

If you have ordered a Backstop with the bore machined by Formsprag proceed to item 2. If the backstop was purchased from the factory as a rough bore, both the C Ring and stub shaft adapter need to be machined as follows:

1. Bore Machining Instructions
 - a. C-Ring Assembly. The C-Ring assembly comes with 0.125" shims installed between the C-ring halves. Machine the CRing assembly as a unit with the shims installed to the maximum size of the mating shaft diameter with a tolerance of 0.000" to 0.001". The surface finish of the machined C-Ring bore should be 30 to 45 micro Ra. Skim cut the C-Ring face with the threaded holes in the same chucking as the boring operation.
 - b. Stub shaft. Machine the face opposite the stub shaft with a blind counter bore to the maximum size of the mating shaft diameter with a tolerance +0.001" to +0.002" and a depth of 0.250". Machine a 15 degree lead in chamfer on the counter bore to a depth not to exceed 0.062". The run out (TIR) between the counter borediameter and the stub shaft diameter must be less than 0.002".
2. Mating Fan Shaft and Torque Arm Requirements. Before installing the backstop, check the following:
 - a. Mating Shaft. The mating shaft of the assembly needs to be round within 0.001" and machined to a surface finish of less than 45 micro Ra. The tolerance of the mating shaft is nominal +0.000" to - 0.001".
 - b. Torque arm stops. Ensure that appropriate equipment frames or structures are available for fastening stops for the backstop's torque arm as shown in the Figure 1.

Installation

1. Dry assemble all components to the fan shaft before completing the assembly with Loctite® to ensure proper fit.
2. Disassemble the C-Ring assembly into two halves by removing two 3/8-24 socket head cap screws. Remove but do not discard the shims.
3. Apply Loctite® 262 to the two 3/8-24 socket head cap screw threads.
4. Reassemble the C-Ring assembly on the fan shaft with the machined face out. Place the shims between the C-Ring halves and outside the dowel and screw holes. The shims will project out of the C-Ring. Lightly tighten the socket head cap screws applying just enough pressure on the shims so they do not fall out but still can be repositioned.
5. Slide the stub shaft onto the fan shaft. Position the C Ring assembly by sliding until it mates against the back face of the stub shaft. Remove the stub shaft. Tap the CRing toward the shaft end 1/16 of inch to ensure that the stub shaft will seat against the C-Ring and not the fan shaft end. The fan shaft will project 0.200" to 0.250" beyond the C-Ring when positioned correctly.
6. Without repositioning the C-Ring, remove the shims and torque down the fasteners a quarter turn at a time, alternating from one fastener to the other to tighten the C-Ring evenly. Torque the 3/8-24 screws to 300 – 450 inch-pounds.

Note: Individually tightening the screws one at a time to the specified torque will damage the C-ring and not provide adequate clamping to the shaft.
7. Slide the stub shaft on the mating shaft. Place the flat washers on the 5/16-24 screws. Apply Loctite 262 to the four 5/16 – 24 socket head cap screw thread and thread them through the holes in the stub shaft and into the C-Ring, hand tight.
8. Verify that the stub shaft is concentric with the fan shaft by keeping the run out on the stub shaft to within 0.002 in. TIR.

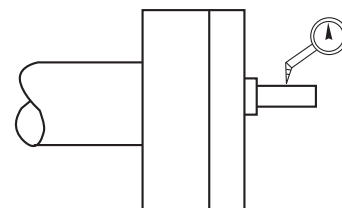

9. Tighten the four 5/16-24 socket head cap screws to 200-240 inch pounds.
10. Apply Loctite® 262 to the torque arm and thread torque arm into the housing. Hand tighten the torque arm until fully seated.

Note: Verify shaft rotation before installing torque arm housing to the stub shaft. Verify that shaft rotation is in the direction of the arrow on the torque arm housing.

11. Coat the stub shaft with anti seize compound. Install the key into the keyway of the stub shaft, and slide the torque arm housing on to the stub shaft. Assemble the bearing retainer plate to the stub shaft. Tighten the 1/4-20 flat head screws to 100 to 120 inch pounds.
10. Attach torque arm stops to equipment frame or supporting structure. The stops are required to prevent rotation of torque arm when holdback torque is applied. Allow clearance between stops and torque arm as shown in the figure. Make sure the torque arm stops can handle the rated torque of the backstop. **DO NOT RIGIDLY MOUNT THE TORQUE ARM. DO NOT WELD, CLAMP, FASTEN OR FIX THE TORQUE ARM – ALLOW THE TORQUE ARM TO FLOAT.** The clearance is necessary to permit free axial and angular movement of the torque arm resulting from shaft run out and eccentricity.

Note: Torque arms may be installed at any angle, however, vertical torque arms should be installed at least 10 degrees from the true vertical position.

Vibration Troubleshooting

1. If unacceptable levels of vibration occur upon installation, disassemble and reinstall being sure to tighten fasteners as described, and verify that the stub shaft adapter sits flush with the C Ring assembly not bottomed out against the mating shaft. Also verify that the torque arm is not bound in any way but is free to float against its stops.
2. Verify that the stub shaft diameter runout does not exceed 0.002 TIR. For minimal vibration reduce the runout to 0.000 TIR or as close as possible.

Lubrication and Maintenance

1. The model FB comes lubricated for life. **CONTACT FORMSPRAG FOR REPLACEMENT TORQUE ARM HOUSING**
2. Replace the torque arm housing sprag clutch every five years to ensure uninterrupted service life. The torque arm housing replacement part number for FB-100 and FB-350 is “FBREPAIR” and for FB-450 is “FBREPAIR-1”. Follow the instructions below:
 - a. Remove the bearing retainer.
 - b. Slide the torque arm housing off the stub shaft adapter.
 - c. Re-install the torque arm housing following the installation procedure starting at step 10.

Rotating Equipment

Rotating Equipment is potentially dangerous and should be properly guarded. The user should check for all applicable safety codes (in local area) and provide a suitable guard. For Application Assistance call 1-800-927-3262.

Warranty

Formsprag LLC warrants that it will repair or replace (whichever in its sole discretion it deems advisable) any product it manufactured and sold which proves to be defective in material or workmanship within a period of one (1) year from date of original purchase for consumer, commercial or industrial use. This warranty extends only to the original purchaser and is not transferable or assignable without Formsprag LLC's prior consent.

This warranty covers normal use and does not cover damage or defect which results from alterations, accident, neglect, disassembly, or improper installation, operation, or maintenance.

Formsprag LLC's obligation under this warranty is limited to the repair or replacement of the defective product. In no event shall Formsprag LLC be liable for consequential, indirect or incidental damages of any kind incurred by reason of manufacture, sale or use of any defective product. Formsprag LLC neither assumes nor authorizes any other person to give any other warranty or to assume any other obligation or liability on its behalf.



Formsprag Clutch
23601 Hoover Road • Warren, MI 48089
586-758-5000 • Fax: 586-758-5204