

High Speed External Backstopping Clutches Model FHB 10, 20 & 60

Service & Installation Instructions

P-222-33
BULLETIN A-4073



 **Formsprag**[®]
Clutch

An **Altra Industrial Motion** Company

Introduction

Formsprags 60+ years of backstopping experience has been used to create a new design with inner race Centrifugal Throw-out Sprags to meet your backstopping requirements for inclined conveyors or bucket elevators that using a Falk® Gear reducer with the backstop mounted externally on the input or intermediate shaft.

Pre-Installation Check

Before installing the clutch, check:

1. Shaft to Bore Fit:

Clutch Bore

0" to 2 " diameter

2" to 4" diameter

Shaft Fit Guide*

Line fit to .0020' loose

Line fit to .0025' loose

*If, under special circumstance, a press fit is necessary, do not exceed .001" tight.

In some cases, builders of equipment in which a Formsprag Clutch is used, specify other shaft fit limits than those listed. In this event, direct your questions concerning the fit limits to the equipment manufacturer.

2. Key and Keyway

For key material use AISI 1141, 1045 or 4130. Harden the key between 30 HRc and 40 HRc (Rockwell C scale).

- **Fit:** In order to prevent breakage, break the edges of the key before installing it onto the shaft. Install the key with a push fit. Do not force fit. Make sure the key seats squarely in the keyway
- **Length:** For proper engagement, the length of the key must be equal to the length of the inner race.

Typical Mounting Arrangements

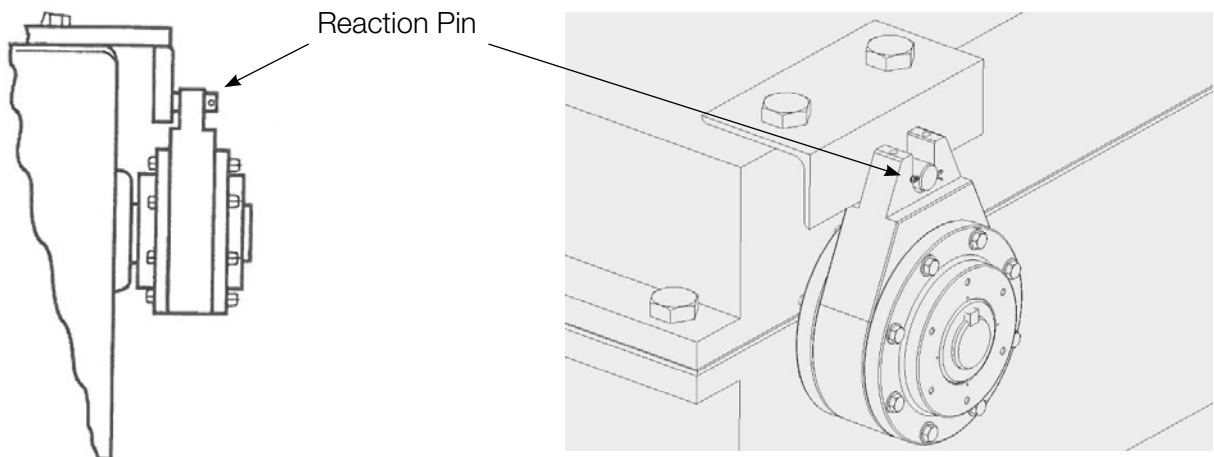

The Model FHB can be axially restrained by a cotter pin in the reaction pin

Figure 1

Figure 2

Installation

1. Install the key and clutch on the shaft as shown in Figure 1 and 2.
2. Apply pressure to the end face of the inner race only. The application of pressure on the end face of the outer race could pre-load and damage the internal ball bearings.
3. Secure the clutch in position on the shaft and use a cotter pin in the reaction pin to prevent outboard axial movement of the backstop shown in Figure 2.
4. Check the clutch for proper installation by verifying the overrunning direction (free-wheeling) it by hand.

The FHB backstop is typically mounted on the double extended input shaft of the gear reducer, opposite from the motor. The FHB backstop inner race is driven by a key in the reducer shaft, and its integral outer race torque arm is prevented from rotating through a clearance fit interface with a fixed reaction pin. The reaction pin may also be used to provide axial restraint of the backstop on the rotating shaft.

Lubrication

Formsprag clutches are lubricated before leaving the factory. The FHB series clutch is designed for lower maintenance and as a result no regular maintenance is required.

To receive the maximum life from the clutch, we recommend that the clutch be sent to Formsprag every third year of operation, for maintenance and lubrication.

The Service interval might be shorter, depending on the kind of environment in which the clutch operates. Under sever operating conditions such as heavy dust or 24/7 operation, maintenance might be required more often. This will ensure a long, effective and trouble-free operation of the clutch.

If the clutch was out of service or in storage for 2 years or more, the level and the quality of the grease in the ball bearings should be checked before the clutch is put back into service.

Clutch Rebuilding Service

Disassembly and repair of Formsprag clutches in the field is not recommended.

Formsprag clutches are precision devices manufactured under careful controls to meet exacting standards. When reconditioning is required, clutches should be returned to Formsprag Clutch directly, through the Distributor, or through the Original Equipment Manufacturer.

Packaging

Your Formsprag clutch, carefully wrapped in Vapor Inhibitor type activated paper for corrosion protection and packed in a shipping box conforming to the requirements of Rule 41, Uniform Freight Classification, may be stored for up to two (2) years and reshipped without added packaging.

These instructions cannot cover all details or variations in equipment and applications nor provide for every possible contingency which may be met in installation, operation or maintenance. For additional technical and dimensional information on FHB Series clutches refer to Formsprag Overrunning Clutch Catalog P-956-FC or call Formsprag Application Assistance at 1-800-927-3262.

Rotating Equipment

Rotating equipment is potentially dangerous and should be properly guarded. The user should check for all applicable safety codes (in local area) and provide a suitable guard.

Warranty

Formsprag LLC warrants that it will repair or replace (whichever in its sole discretion it deems advisable) any product it manufactured and sold which proves to be defective in material or workmanship within a period of one (1) year from date of original purchase for consumer, commercial or industrial use. This warranty extends only to the original purchaser and is not transferable or assignable without Formsprag LLC's prior consent.

This warranty covers normal use and does not cover damage or defect which results from alterations, accident, neglect, disassembly or improper installation, operation or maintenance.

Formsprag LLC's obligation under this warranty is limited to the repair or replacement of the defective product. In no event shall Formsprag LLC be liable for consequential, indirect or incidental damages of any kind incurred by reason of manufacture, sale or use of any defective product. Formsprag LLC neither assumes nor authorizes any other person to give any other warranty or to assume any other obligation or liability on its behalf.

These instructions cannot cover all details or variations in equipment and applications nor provide for every possible contingency which may be met in installation, operation or maintenance. Should further information be needed, contact Formsprag Clutch at 1-800-927-3262.



www.formsprag.com

23601 Hoover Road
Warren, MI 48089
586-758-5000
Fax: 586-758-5204

An **Altra Industrial Motion** Company

