

High Performance Indexing Clutches Models HPI 300 thru 1027

P-222-6

BULLETIN 2213

Service & Installation Instructions

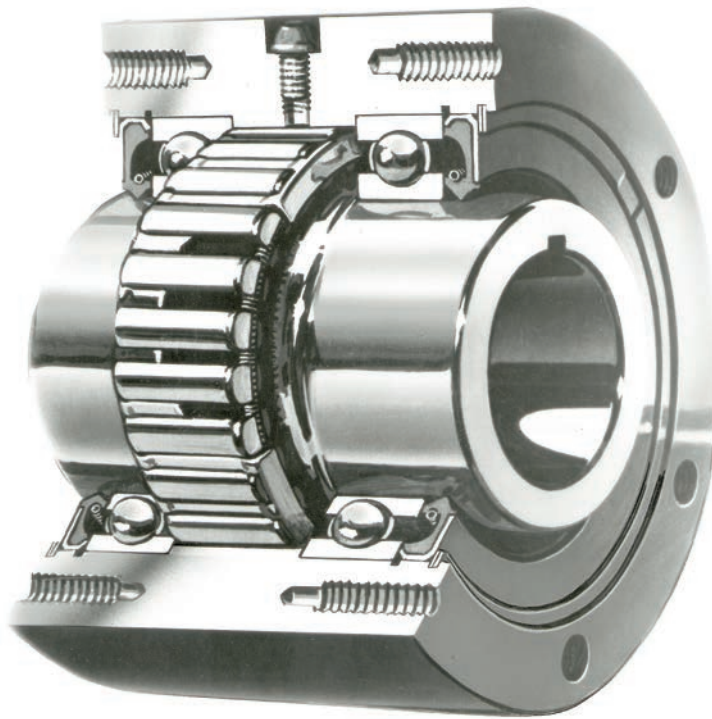

Introduction

The HPI Model High Performance Indexing Clutches are especially designed for medium and heavy-duty indexing applications, or applications where the indexing rate exceeds 150 strokes per minute. They feature Formchrome® sprags and Formsprag's exclusive "Free-Action" Retainer for long life and instant engagement. Models 300 thru 700 incorporate the advanced PCE sprags.

- Formsprag HPI clutches mount on a through-shaft, with the inner race driven by a key.
- The O.D. of the outer race is designed as a mounting surface or pilot for attaching the driven member.
- The O.D. of the outer race is ground concentric with the bore to provide for proper alignment and installation.

⚠ WARNING Failure to follow these instructions may result in product damage, equipment damage, and serious or fatal injury to personnel.

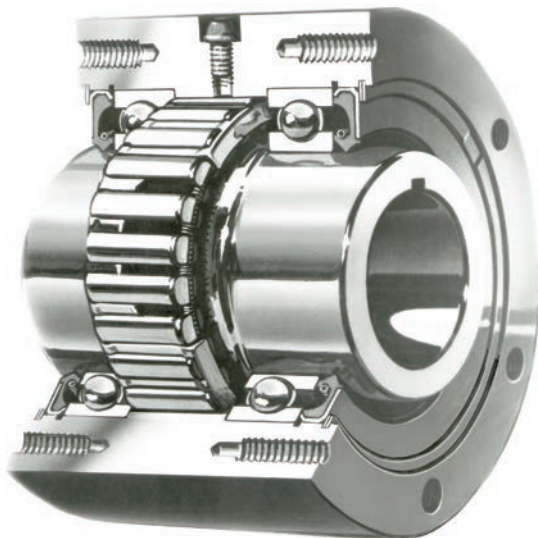

HPI-300-700

Pre-Installation Check

Before installing, check:

1. Shaft to Bore fit:

Clutch Bore	Shaft Fit Guide*
to 2 inches dia.	Line fit to .002 inches loose
2 to 4 inches dia.	Line fit to .0025 inches loose
4 to 7 inches dia.	Line fit to .003 inches loose

*If a press fit is necessary under special circumstances, do not exceed .001 inch tight.

In some cases, builders of equipment in which a Formsprag Clutch is used, specify other shaft fit limits than those listed. In this event, direct questions concerning fit limits to the equipment manufacturer.

2. Key and keyseat

Hardness: Use a hardened key, from 30 to 40 Rockwell "C" scale. Use materials AISI 1141, 1045 or 4130.

Length: The key must be equal to the length of the inner race for proper engagement.

Fit: Fit the key up to .001 inch interference on Width dimension to prevent loosening in indexing service. Do not exceed .001 inch tight. Break edges of the key, before installing, to prevent any load bearing at these points. Be sure the key seats squarely.

3. **Rotation:** Check the clutch for the proper rotation in each application. Turn the inner race to check overrunning direction.

4. For Vertical shaft mounted applications, contact Formsprag Clutch prior to installation.

Installing

1. Mount the clutch and key on the shaft.

Note: Oil lubricated clutches should be mounted on horizontal shafts only. For vertical shaft mountings of oil lubricated clutches contact Formsprag Clutch.

2. Apply pressure to end face of the clutch inner race only.

Application of pressure to the outer race could load the bearings excessively causing permanent damage. For oil lubricated clutches, to simplify mounting, if a .001 inch interference fit is required, (this is the tightest allowable) immerse the clutch in hot, clean oil (not to exceed 200°F/93°C) for ten to fifteen minutes before mounting.

3. Secure the clutch in position on the shaft.

Use a lock washer and nut, a flat washer fastened to the shaft end with a screw, snap rings, collars, etc. to keep the clutch in position on the shaft.

4. Mount attaching parts to the clutch outer race as required by the application.

Tapped mounting holes are provided in each end of the outer race. Center the gear, pulley or sheave on the outer race. Avoid excessive over-hung loads.

Check with Formsprag Clutch if the clutch must support large side loads during overrunning cycle of operation.

1. All fasteners are recommended to be grade 8 bolts.

5. All Formsprag clutches are lubricated before leaving the factory. However, check the following Lubricant table for the proper lubricant and fill level for each type application and ambient operating temperature range. Change the lubricant or add oil to proper level, if required.

6. Check for proper installation by overrunning (free-wheeling) the clutch by hand.

Lubrication

Proper lubrication and lubricant maintenance are the most important single maintenance factors for long, effective, trouble-free clutch operation. Read the following instructions and follow them carefully for maximum performance and utilization of Formsprag overrunning clutches. Always recheck oil level in clutch after installation and before start up.

Oil Lubrication

Use oils selected from the following table according to the index rate and ambient temperature existing at the clutch.

Note: Clutches shipped from Formsprag Clutch contain Mobil DTE Light Oil.

Check to be sure that the clutch has the proper amount of oil (7/8 full) before operation.

Temperature Range	Recommended Lubricant
+40°F to + 150°F (+5°C to +65°C)	Mobil DTE Light Oil Mobil SHC-624 Texaco Regal R&O No. 32 Shell Turbo Oil 32 Exxon Teresstic 32 Amoco Industrial 32 Any Automatic Transmission Fluid (ATF) Sunoco Sunvis 916 Texaco 2 Texamatic Fluid 9226
150 strokes per minute or more +40°F to +150°F (+5°C to +65°C)	Chevron GST Oil 46 Sunoco Sunvis 921 Any Automatic Transmission Fluid (ATF)

Note: Maximum permissible ambient temperature is +150°F (+65°C). If the ambient temperature is below +40°F (+5°C) consult Formsprag Clutch for lubricant recommendation.

⚠ CAUTION Do not use lubricants of the EP/AW type (extreme pressure or anti wear characteristics) or those containing slippery additives.

⚠ WARNING The use of lubricants in clutch assemblies, other than those shown, can result in improper sprag engagement. Improper sprag engagement may cause personal injury or property damage.

Formsprag Clutch is not responsible for any changes made by the manufacturers in their lubricants.

The use of any lubricants, other than those listed in this manual, will automatically void any warranty.

Important: Do not mix oils, they are not compatible. When switching from one brand to another, drain old oil and flush clutch with mineral spirits. **DO NOT** use carbon tetrachloride before adding new oil.

Oil Lubrication Maintenance

1. Lubrication is the most important clutch maintenance factor for longer service life.
2. Check the oil level once a month or every 160 hours of operation, whichever occurs first. If the clutch indexes at more than 150 strokes per minute, oiling may be required at shorter intervals. Add oil, if necessary, to maintain the clutch at the proper oil level.
3. To assure continued efficiency of operation, flush clutch every 6 months with mineral spirits. Do not use carbon tetrachloride.

▲CAUTION Under severe operation conditions, such as heavy dust or twenty-four hours per day operation, flushing may be required at shorter intervals.

4. Flush with mineral spirits and relubricate before use if clutch has been stored or out of use for six months or more. Flushing will remove waxes or gums formed by vaporization of the oil. (See Flushing Procedure.)

Oil Lubrication – Filling Procedure

1. Rotate the clutch outer race to locate two oil ports at positions (A) and (B). (See Figure 1)
2. Remove oil plugs (A) and (B) and add oil through (A) until oil flows from (B). Use a pressure can for best results.
3. Install both plugs and tighten to prevent leakage. (See Figure 1)

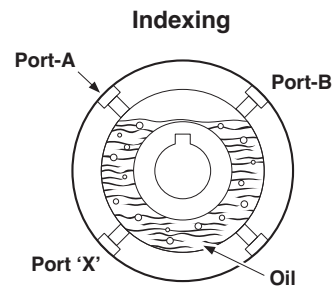

Note: Models HPI-300 through -600 do not have a fourth Oil Port (Port 'X'). Position clutch as shown for filling

Figure 1

Flushing Procedure

1. Rotate clutch outer race to locate on oil port at lowest point of outer race.
2. Remove lowest plug and drain clutch of oil. Remove upper plugs for venting and better drainage.
3. Install bottom drain plug and fill clutch with mineral spirits. Install filling plugs.
4. Rotate clutch slowly for several minutes to break up and dissolve oily residue and waxes which may have formed. Indexing clutches may be operated for five to ten minutes to do this.
5. Remove lower plug and drain all mineral spirits from the clutch assembly. Remove upper plugs for venting for better drainage.
6. Replace all oil hole plugs.
7. Relubricate clutch according to **Oil Lubrication Filling Procedure.**

Grease Lubrication

Properly maintained, oil is the most effective lubricant for HPI clutches. Grease-lubricant clutches may be provided on special request, for indexing rates up to 250 strokes per minute, under the following conditions:

- The clutch is inaccessible for frequent maintenance.
- Conditions do not permit the type of maintenance required for oil lubricated clutches.
- The clutch is mounted on a vertical shaft.
- The clutch must be operated continuously.
- The clutch will be operated in the presence of severe abrasive dust.

Use greases selected from the following table:

- Fiske Bros. Lubriplate Low-Temp
- Fiske Bros. Aero Lubriplate
- Standard Rykon No. 1
- Shell Alvania No. 1
- Shell Aeroshell No. 7
- Shell Aeroshell No. 16

Note: Grease lubricated HPI-300 thru HPI-700 are packed at the factory with Fiske Brothers Lubriplate Low-Temp and HPI-750 thru HPI-1027 are packed with Fiske Brothers Aero Lubriplate.

Important: Do not mix the above greases, they are not compatible. When switching from one brand to another, pump a sufficient amount of grease into the clutch to insure all the previous grease has been purged out.

Do not attempt to substitute oil lubrication in a standard grease lubricated clutch. The use of oil lubrication in a clutch intended for grease could cause a malfunction.

Formsprag Clutch can convert in-service clutches from grease to oil lubrication. Changes in internal construction are usually required. Consult Formsprag Service Department, giving complete model number.

- Use no other grease unless a specific recommendation has been made by Formsprag Clutch.
- For indexing rates in excess of 250 strokes per minute, where grease lubrication is required, consult Formsprag Clutch for special lubricant recommendations.
- If operation at temperature below 20°F (-7°C) is required, consult Formsprag Clutch for special lubricant recommendations.

Grease Lubrication Maintenance

Regrease	Regrease Under Rugged Conditions*
Once a month	Every two weeks

*24 hours per day or operation in severe abrasive dust conditions.

Grease Lubrication Procedure

1. Select one grease fitting on the clutch for regreasing and wipe it clean.
2. Pump grease into the clutch until clean grease flows out completely around the seals on both sides of the clutch.

Note: It is normal for a clutch to leak or sling grease from around the seals for a short period of time (approximately 1/2 to 1 hour) during operation after relubrication.

Packaging

Your Formsprag clutch is carefully wrapped in Vapor Inhibitor type activated paper for corrosion protection and packed in a shipping box conforming to the requirements of Rule 41, Uniform Freight Classification. It may be stored for up to two (2) years and reshipped without added packing. To store in an unprotected area or, if the original packaging is opened, wrap the box with a waterproof covering.

Clutch Rebuilding Service

Disassemble and repair of Formsprag clutches in the field is not recommended.

Formsprag clutches are precision devices manufactured under careful controls to meet exacting standards. When reconditioning is required, clutch should be returned to Formsprag Clutch (Purchase Orders must go directly through your local Warner Electric Distributor or through the Original Equipment Manufacturer).

These instructions cannot cover all details or variations in equipment and applications, nor provide for every possible contingency which may be met in installation, operation or maintenance. Should further information be needed, contact Formsprag Clutch.

For additional technical and dimensional information on HPI clutches refer to Formsprag Overrunning Clutch Catalog P-956 or 1-800-927-3262.

Rotating Equipment

Rotating equipment is potentially dangerous and should be properly guarded. The user should check for all applicable safety codes (in local area) and provide a suitable guard.

Warranty

Formsprag Clutch LLC warrants that it will repair or replace (whichever in its sole discretion it deems advisable) any product it manufactured and sold which proves to be defective in material or workmanship within a period of one (1) year from date of original purchase for consumer, commercial or industrial use. This warranty extends only to the original purchaser and is not transferable or assignable without Formsprag LLC's prior consent.

This warranty covers normal use and does not cover damage or defect which results from alterations, accident, neglect, disassembly, or improper installation, operation, or maintenance.

Formsprag LLC's obligation under this warranty is limited to the repair or replacement of the defective product. In no event shall Formsprag LLC be liable for consequential, indirect or incidental damages of any kind incurred by reason of manufacture, sale or use of any defective product. Formsprag LLC neither assumes nor authorizes any other person to give any other warranty or to assume any other obligation or liability on its behalf.



Formsprag Clutch
23601 Hoover Road • Warren, MI 48089
586-758-5000 • Fax: 586-758-5204
www.formsprag.com
An Altra Industrial Motion Company