

General Purpose Overrunning Clutches FRB 400 through 800

Installation Instructions

P-4050-FC
BULLETIN 3045



 **Formsprag**[®]
Clutch

An **Altra Industrial Motion** Company

Introduction

The FRB Series clutches utilize a high speed, centrifugal C/T (throw-out) sprag design and the clutch is supported by sealed ball bearings.

These C/T sprags are designed to “lift-off” from the races during high speed inner race over-running.

In this design, the center of mass of the sprag is located so that when the inner race is over-running, the centrifugal force of the sprag overcomes the force of the energizing springs causing the sprags to completely “pull-away” from the outer race.

The advantage of using C/T sprags is that when over-running at above the lift-off speed, there is no contact between the sprags and the races, hence there is no wear (for a longer operating life), no heat being generated (the clutch runs cooler) and no sprag drag (resistance after run-in is lower).

With sealed bearings, this design does not require any regular maintenance.

Overrunning Applications

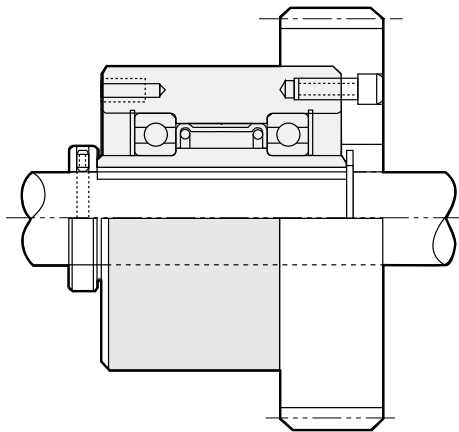

The FRB Series is a special design clutch, suitable for both low-speed driving and high speed overrunning and back-stopping applications.

- Formsprag ball bearing clutches are mounted on a through-shaft with the inner race driven by a key.
- The outer diameter of the outer race is designed as a mounting surface for attaching the driven member.
- The outer diameter of the outer race is precision ground so that it can be used as a pilot diameter for mating components.

Backstopping Applications

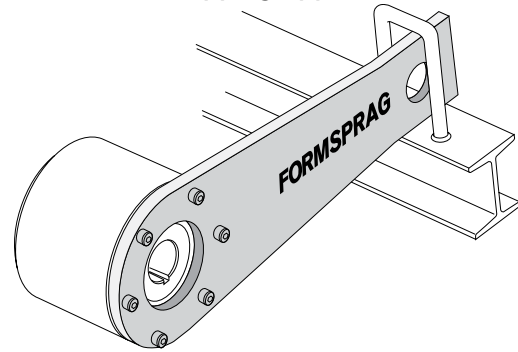

The FRB clutch must be secured to the shaft by customer supplied snap-ring, set collar, spacer, etc, in order to provide axial restraint.

All fasteners are recommended to be grade 8 or higher.

⚠ WARNING Failure to follow these instructions may result in product and equipment damage and in serious or fatal injury to personnel.

Pre-installation Check

Before installing the clutch, check:

1. Shaft to Bore fit:

Clutch Bore	Shaft Fit Guide*
0" to 2" diameter	Line fit to 0.0020" loose
2" to 4" diameter	Line fit to 0.0025" loose
4" to 7" diameter	Line fit to 0.0030" loose

* If, under special circumstances, a press fit is necessary, do not exceed 0.001" tight.

In some cases, builders of equipment in which a Formsprag Clutch is used, specify other shaft fit limits than those listed. In this event, direct your questions concerning the fit limits to the equipment manufacturer.

2. Key and Keyway

For key material use AISI 1141, 1045 or 4130. Harden the key between 30 HRc and 40 HRc (Rockwell C scale).

- **Fit:** In order to prevent breakage, break the edges of the key before installing it onto the shaft. Install the key with a push fit. Do not use force fit. Make sure that the key seats squarely in the keyway.
- **Length:** For proper engagement, the length of the key must be equal to the length of the inner race.

3. Rotation

Check the clutch for the proper rotation in each application. Turn the inner race to check for the proper overrunning direction.

Installation

1. Install the key and the clutch on the shaft.
2. Apply pressure to the end face of the inner race only. The application of pressure on the end face of the outer race could pre-load the ball bearings excessively.

⚠ WARNING Do not heat the clutch in the installation process. If you heat the clutch in order to install it on the shaft, the grease in the ball bearing will melt, the clutch will not function properly and its life will be dramatically reduced.

3. Secure the clutch in position on the shaft. Use a lock washer and nut, a flat washer fastened to the shaft end with a screw, snap-rings, set collars or similar retaining methods in order to provide positive axial restraint.
4. Install the mating components to the outer race of the clutch as required by the application. All the fasteners are recommended to be Grade 8 or higher.
5. If a torque arm must be installed on the clutch, allow 0.25" to 0.50" clearance between the arm and the torque arm stops. The torque arm must not be rigidly mounted to the reaction surface.
6. Tapped holes are provided on both ends of the outer race. Center the gear, pulley or sheave on the outer race. Avoid excessive over-hung loads.

⚠ CAUTION Check with Formsprag Clutch if the clutch must support any side loads during the overrunning cycle of operation.

7. Check the clutch for proper installation by verifying the overrunning direction (free-wheeling) it by hand.

⚠ WARNING Rotating equipment is potentially dangerous and should be properly guarded. The user should check for all the applicable safety codes and regulations in his area and provide a suitable guard.

Lubrication

Formsprag clutches are lubricated before leaving the factory. The FRB Series clutch is designed for lower maintenance and as a result no regular maintenance is required.

⚠ WARNING Do not add any oil or grease to the FRB Series clutch.

We recommend that the clutch be sent to Formsprag every third year of operation, for maintenance and lubrication.

The service interval might be shorter, depending on the kind of environment in which the clutch operates.

Under severe operating conditions such as heavy dust or 24/7 operation, maintenance might be required more often. This will ensure a long, effective and trouble-free operation of the clutch.

Packaging

Your Formsprag FRB clutch was carefully wrapped at the factory in vapor inhibitor type paper, for corrosion protection.

Models 400 through 700 are packed in corrugated board shipping boxes and models 750 through 800 are packed in wooden, style 4 shipping boxes with integral skids, conforming to the requirements of Rule 41 of Uniform Freight Classification. These clutches may be stored for up to 2 years and re-shipped without added packaging.

To store the clutch in an unprotected area or if the original package is opened, wrap the box with a water-proof covering.

Service and Rebuilding

⚠ CAUTION Disassembly and repair of Formsprag clutches in the field IS NOT RECOMMENDED.

All the FRB Formsprag clutches are high precision devices, manufactured under careful control to meet the exact standards.

When maintenance or reconditioning is required, the FRB clutches should be returned to Formsprag Clutch.

Purchase Orders must go directly through your local authorized Formsprag Distributor or through the Original Equipment Manufacturer.

These instructions can neither cover all the details or variations in equipment and applications nor provide for every possible contingency which may be met in installation or operation.

If further information is needed, please visit our website www.formsprag.com or contact Formsprag Clutch directly at 1-800-927-3262.

For additional technical and dimensional information on FRB clutches refer to Formsprag Overrunning Clutch Catalog P-956-FC or call 1-800-927-3262

Warranty

Formsprag LLC warrants that it will repair or replace (whichever in its sole discretion it deems advisable) any product it manufactured and sold which proves to be defective in material or workmanship within a period of one (1) year from date of original purchase for consumer, commercial or industrial use. This warranty extends only to the original purchaser and is not transferable or assignable without Formsprag LLC's prior consent.

This warranty covers normal use and does not cover damage or defect which results from alterations, accident, neglect, disassembly or improper installation, operation or maintenance.

Formsprag LLC's obligation under this warranty is limited to the repair or replacement of the defective product. In no event shall Formsprag LLC be liable for consequential, indirect or incidental damages of any kind incurred by reason of manufacture, sale or use of any defective product. Formsprag LLC neither assumes nor authorizes any other person to give any other warranty or to assume any other obligation or liability on its behalf.

These instructions cannot cover all details or variations in equipment and applications nor provide for every possible contingency which may be met in installation, operation or maintenance. Should further information be needed, contact Formsprag Clutch at 1-800-927-3262.



www.formsprag.com

23601 Hoover Road
Warren, MI 48089
586-758-5000
Fax: 586-758-5204

An **Altra Industrial Motion** Company

