

Guardian FBA Flywheel Coupling

Service & Installation Instructions

P-8602-GC
GUA-MRK-DOC-010



TABLE OF CONTENTS

| | |
|---------------------------------------|--------|
| NOTICES AND WARNINGS | PAGE 2 |
| SECTION 1 – COUPLING OVERVIEW | PAGE 3 |
| SECTION 2 – TOOLS/MATERIALS REQUIRED | PAGE 4 |
| SECTION 3 – INSTALLATION INSTRUCTIONS | PAGE 4 |
| SECTION 4 – REFERENCE DATA | PAGE 4 |
| SECTION 5 – STORAGE | PAGE 4 |
| WARRANTY | PAGE 6 |

IMPORTANT READ ALL NOTICES & WARNINGS BEFORE ATTEMPTING ANY INSTALLATION!

NOTICES:

- PLEASE CAREFULLY READ OVER AND UNDERSTAND INSTRUCTIONS BEFORE ATTEMPTING ANY MAINTENANCE. IF ADDITIONAL ASSISTANCE IS NEEDED PLEASE CONTACT GUARDIAN BEFORE SERVICING/INSTALLING THE PRODUCT.
- WHILE GUARDIAN MAKES EVERY EFFORT TO ENSURE THE ACCURACY OF THE INFORMATION PROVIDED, WE MAKE NO WARRANTY AS TO THE ACCURACY OR COMPLETENESS OF SAID INFORMATION. THE INFORMATION PROVIDED CORRESPONDS TO THE INSTALLATION STANDARDS AT THE TIME OF PRINTING.
- THESE INSTALLATION INSTRUCTIONS ACT AS GENERAL GUIDELINES, AND DO NOT COVER EVERY SCENARIO. IF YOUR INSTALLATION DOES NOT APPLY, PLEASE CONTACT GUARDIAN TO FURTHER REVIEW YOUR APPLICATION TO ENSURE PROPER INSTALLATION IS COMPLETED.
- ENSURE PROPER SIZING AND OFFSETS TO AVOID CAUSING DAMAGE TO THE MACHINERY AND/OR COUPLING.
- KEEP COUPLINGS FREE OF DUST AND GRIME TO ENSURE LONG LIFE.
- VERIFY APPLICATION DATA AND REVIEW TORQUE SPECIFICATIONS, MIS-ALIGNMENT, AND APPLICATION SERVICE FACTORS. IF FURTHER ASSISTANCE IS NEEDED PLEASE CONTACT GUARDIAN COUPLINGS.
- HUBS THAT ARE MODIFIED OR MACHINED BY THE CUSTOMER ARE NOT COVERED UNDER THE STANDARD WARRANTY TERMS. IF MODIFICATIONS ARE MADE BY THE CUSTOMER IT IS RECOMMENDED THAT THE CUSTOMER ADHERES TO GUARDIAN MACHINING STANDARDS TO ENSURE PROPER OPERATION.
- FBA COUPLINGS ARE CONSIDERED A ONE-PIECE COUPLING DESIGN, DO NOT DISASSEMBLE COUPLING

WARNINGS:

- DISENGAGE ALL POWER TO NECESSARY MACHINERY BEFORE PERFORMING ANY WORK ON THE ASSEMBLY. MAKE SURE NO ACCIDENTAL ENGAGEMENT CAN OCCUR.
- IMPROPER USE OR INSTALLATION MAY RESULT IN SERIOUS INJURY OR DEATH. GUARDIAN COUPLINGS WILL NOT BE LIABLE FOR IMPROPER USE/INSTALLATION OF THE PRODUCTS. THE PURCHASER/INSTALLER IS RESPONSIBLE FOR PROPER INSTALLATION, SAFEGUARDS, MAINTENANCE AND OPERATION OF THE PRODUCT AND EQUIPMENT.
- ANY MODIFICATIONS TO INSTRUCTIONS AND/OR COUPLING CHARACTERISTICS MAY RESULT IN A PREMATURE FAILURE.
- MAKE SURE THAT THE COUPLING IS NOT IN CONTACT WITH ANY NON-ROTATING SURFACES.
- IF ANY PROBLEMS OCCUR DURING ASSEMBLY, CONTACT GUARDIAN COUPLINGS IMMEDIATELY.
- THIS PRODUCT CONTAINS WEAR ELEMENTS THAT WILL EVENTUALLY FAIL. MAKE SURE THE ASSEMBLY IS ADEQUATELY COVERED/ENCLOSED TO AVOID INJURY IN CASE OF A FAILURE.
- WARNING: THIS PRODUCT MAY CONTAIN CHEMICALS KNOWN TO THE STATE OF CALIFORNIA TO CAUSE CANCER AND/OR BIRTH DEFECTS OR OTHER REPRODUCTIVE HARM.

SECTION 1 – COUPLING OVERVIEW

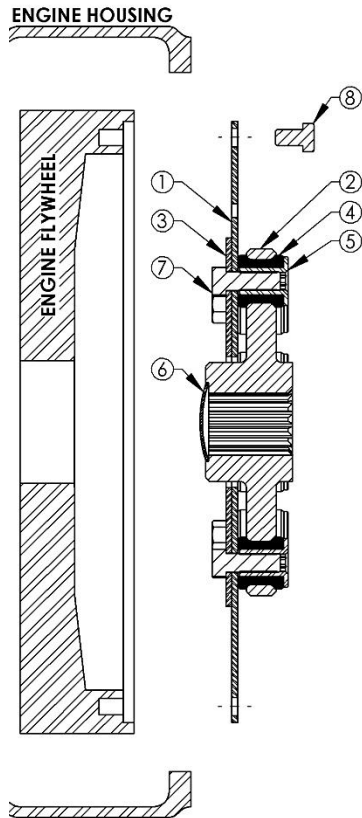

FIGURE 1.1 FBA COUPLING CROSS SECTION

| ITEM NUMBER | ITEM DESCRIPTION |
|-------------|------------------------------|
| 1 | FBA COUPLING FLYWHEEL |
| 2 | FBA COUPLING HUB |
| 3 | FBA SUPPORT PLATE (OPTIONAL) |
| 4 | FBA RUBBER GROMMET |
| 5 | FBA STEEL INSERT |
| 6 | GREASE PLUG (OPTIONAL) |
| 7 | FBA COUPLING BOLTS |
| 8 | COUPLING MOUNTING HARDWARE* |

*SHOWN FOR REFERENCE ONLY – NOT INCLUDED WITH COUPLING

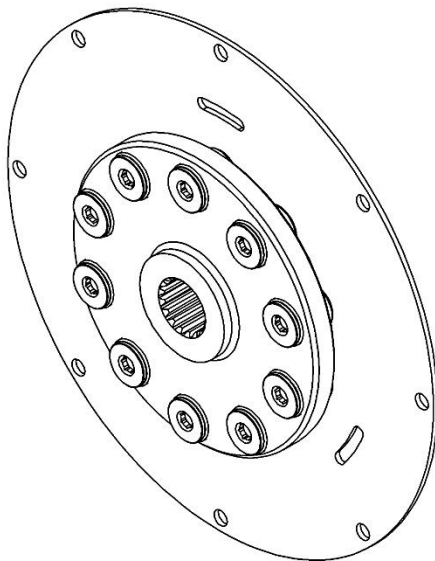

FIGURE 1.2 FBA COUPLING (HUB SIDE)

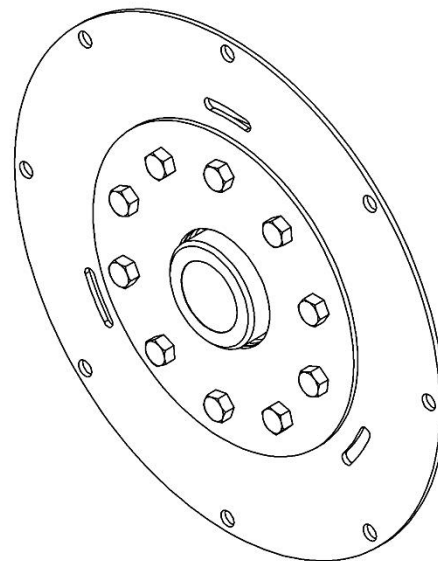

FIGURE 1.3 FBA COUPLING (BOLT HEAD SIDE)

SECTION 2 - TOOLS/MATERIAL REQUIRED

- TORQUE WRENCH
- ALLEN SOCKETS
- MEDIUM STRENGTH REMOVABLE LOCTITE
- FBA COUPLING GREASE (SUPPLIED WITH COUPLING)

SECTION 3 – INSTALLATION INSTRUCTIONS

- 1) **PLEASE READ & FOLLOW ALL NOTICES & WARNINGS PRIOR TO INSTALLATION OF THIS PRODUCT**
DISENGAGE ALL POWER TO NECESSARY MACHINERY BEFORE PERFORMING ANY WORK ON THE ASSEMBLY
MAKE SURE NO ACCIDENTAL ENGAGEMENT CAN OCCUR
- 2) INSTALL AND MATE COUPLING WITH ENGINE FLYWHEEL PILOT AND MOUNTING HOLES
SAE 6-1/2 THRU SAE 11-1/2 COUPLINGS SHOULD BE INSTALLED WITH BOLT HEAD SIDE TOWARD FLYWHEEL
SAE 14 COUPLINGS SHOULD BE INSTALLED WITH BOLT HEAD SIDE AWAY FROM FLYWHEEL
(COUPLING ORIENTATION IS BASED ON STANDARD SAE FLYWHEEL OFFSETS)
- 3) WITH COUPLING HOLES ALIGNED, INSTALL PROPERLY SIZED BOLTS INTO COUPLING MOUNTING HOLES
GUARDIAN RECOMMENDS USING MEDIUM STRENGTH REMOVABLE LOCTITE
(SEE TABLE 4.1 FOR STANDARD SAE ENGINE FLYWHEEL HOLE SIZES)
- 4) ENSURING COUPLING IS FLAT WITH ENGINE FLYWHEEL, TORQUE BOLTS TO RECOMMENDED SEATING TORQUE
(SEE TABLE 4.1 FOR BOLT SEATING TORQUES)
- 5) APPLY LUBRICATING GREASE TO COUPLING SPLINE AND MATING SPLINED SHAFT
GUARDIAN RECOMMENDS USING SHELL ALVANIA CG GREASE (GREASE SUPPLIED WITH COUPLING)
- 6) COUPLING IS NOW READY FOR INSTALLATION OF PUMP/ENGINE HOUSING
REFER TO GUARDIAN’S SUPPLEMENTARY INSTALLATION INSTRUCTIONS FOR FURTHER ASSISTANCE

SECTION 4 - REFERENCE DATA

TABLE 4.1 SAE – J620d ENGINE FLYWHEEL HOLE SIZES AND SEATING TORQUES

| SAE FLYWHEEL SIZE | | 6-1/2 | 7-1/2 | 8 | 10 | 11-1/2 | 14 | 18 |
|-----------------------|--------|----------------|-------|---------------|----|--------|---------------|---------------|
| IMPERIAL BOLTS | | 5/16-18 | | 3/8-16 | | | 1/2-13 | 5/8-11 |
| SEATING TORQUE | FT-LBS | 19 | | 34 | | | 85 | 170 |
| | Nm | 26 | | 46 | | | 115 | 230 |
| METRIC BOLTS | | M8 | | M10 | | | M12 | M16 |
| SEATING TORQUE | FT-LBS | 20 | | 40 | | | 70 | 155 |
| | Nm | 27 | | 54 | | | 95 | 210 |

SECTION 5 - STORAGE

- COUPLINGS SHOULD BE STORED IN A DRY, WELL MAINTAINED ENVIRONMENT
- HUMID STORAGE ENVIRONMENTS COULD LEAD TO SURFACE RUST ON THE HUB AND SPLINE BORE
(INSPECT SPLINE BORE FOR RUST AND BURRS PRIOR TO INSTALLATION)

WARRANTY

Guardian Ind. Inc. warrants that the Goods will be free from defects in material and workmanship for a period of twelve (12) months from delivery, or such other period as shall be agreed upon in writing by the parties. Guardian Ind. Inc.'s limited warranty excludes remedy for damage or defect caused by abuse; failure to resist corrosion or erosion from any corrosive agent or fluid, or due to deposits of foreign material from any fluid; modifications not executed by Guardian Ind. Inc.; improper installation or operation; defects or failures arising out of, in any way related to, or as a result, either direct or indirect, of the Buyer's failure to properly advise Guardian Ind. Inc. of all normal and special operating conditions, known to or suspected by the Buyer, when Guardian Ind. Inc. is manufacturing the Product for a specific operation; or normal wear and tear under normal usage. All weights stated in Guardian Ind. Inc.'s catalog and lists are approximate and are excluded from this warranty. EXCEPT AS EXPRESSLY SET FORTH IN THIS PARAGRAPH, GUARDIAN IND. INC. MAKES NO OTHER WARRANTY WITH RESPECT TO THE GOODS DELIVERED HEREUNDER AND EXPRESSLY DISCLAIMS ALL OTHER WARRANTIES, EXPRESS OR IMPLIED, INCLUDING WARRANTIES OF MERCHANTABILITY AND OF FITNESS FOR A PARTICULAR PURPOSE, ARISING BY OPERATION OF LAW OR OTHERWISE.

Guardian Ind. Inc. must be notified in writing of any defect in the Goods within a reasonable period of time after discovery (not to exceed thirty (30) days) and the defective Goods must be delivered within the warranty period specified above, prepaid, to Guardian Ind. Inc.'s factory, with evidence that the Goods have been properly installed, maintained and operated in accordance with Guardian Ind. Inc.'s instructions. If Guardian Ind. Inc. determines that any such returned Goods are not in conformity with the warranty set forth herein, then Guardian Ind. Inc. shall, at its sole option and expense, either repair the same or supply replacement Goods.

The remedies of Buyer set forth herein are exclusive, and the total liability of Guardian Ind. Inc. hereunder, whether based on contract, warranty, negligence, indemnity, strict liability or otherwise, and shall not exceed the purchase price of the Goods giving rise to any such claim for liability. IN NO EVENT SHALL GUARDIAN IND. INC. OR ITS SUPPLIERS BE LIABLE TO BUYER, ANY SUCCESSORS IN INTEREST, OR ANY BENEFICIARY OF THIS CONTRACT FOR CONSEQUENTIAL, INDIRECT, INCIDENTAL, OR SPECIAL DAMAGES OR LOSSES, OR FOR ANY SECONDARY CHARGES OR ADMINISTRATIVE OR PUNITIVE DAMAGES, FINES, PENALTIES, FEES, EXPENSES AND OTHER CHARGES, ARISING OUT OF THE CONTRACT OR ANY BREACH THEREOF, WHETHER BASED UPON LOSS OF USE, LOSS OF PRODUCTION, LOST PROFITS OR REVENUE, INTEREST, LOST GOODWILL, WORK STOPPAGE, IMPAIRMENT OF OTHER GOODS, LOSS BY REASON OF SHUTDOWN OR NON-OPERATION, INCREASED EXPENSES OF OPERATION OR CLAIMS OF CUSTOMERS OF BUYER FOR SERVICE INTERRUPTION, OR ANY OTHER TYPE OF ECONOMIC LOSS OR DAMAGE, WHETHER OR NOT SUCH LOSS OR DAMAGE IS BASED ON CONTRACT, WARRANTY, NEGLIGENCE, INDEMNITY, STRICT LIABILITY OR OTHERWISE.

Further details pertaining to TERMS AND CONDITIONS OF SALES can be found at the following link:

http://www.altramotion.com/~media/Files/Corporate/Terms%20and%20Conditions/Sales-Terms/Guardian_Sales_Terms.ashx



www.guardiancouplings.com

300 Indiana Highway 212
Michigan City, IN 46361
219-874-5248
Fax: 219-879-6643