

Electromagnetic Power-On Friction Clutches & Brakes

Power-On Clutches & Brakes Description

Screw Terminals Standard On Larger Sizes; Smaller Sizes with Leads, UL Recognized Materials

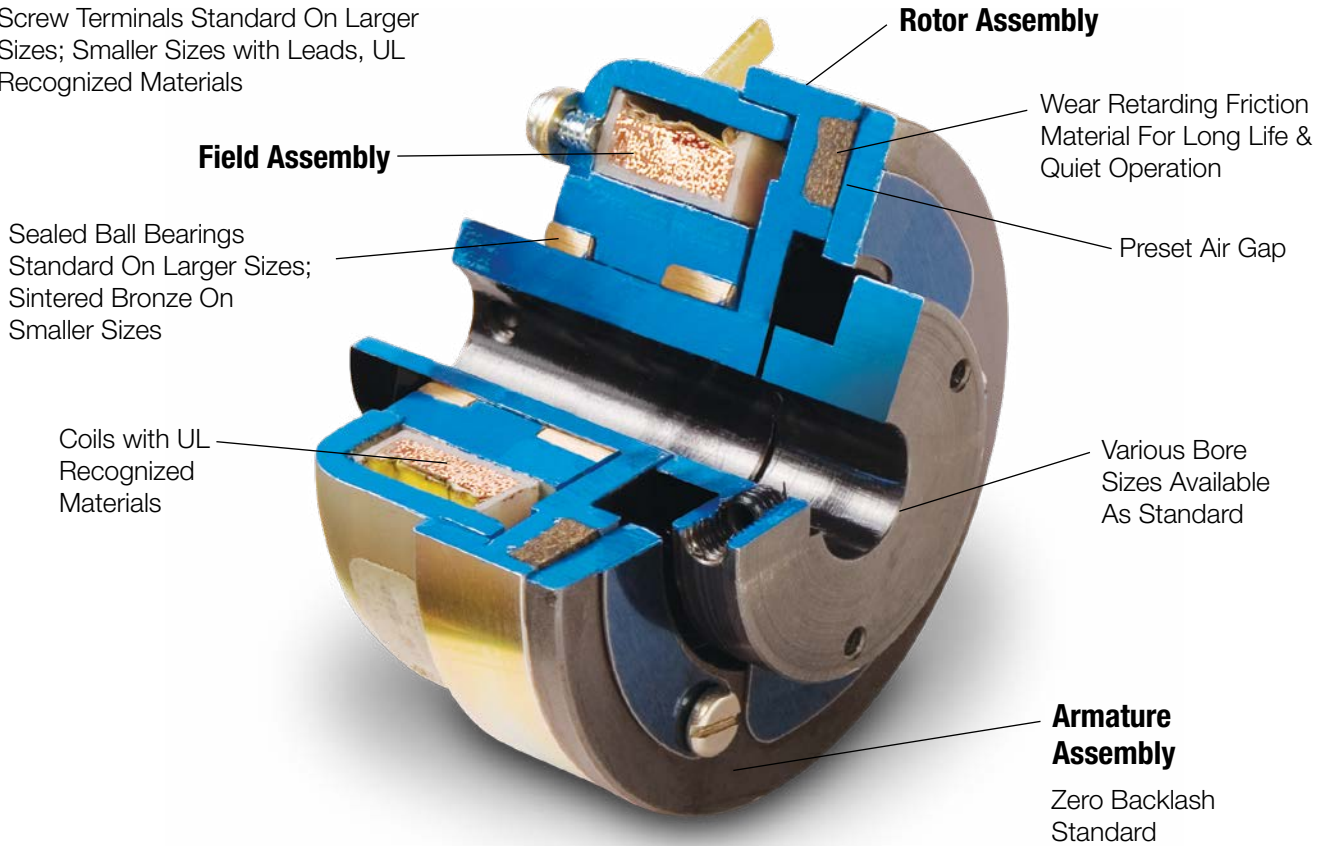

Model SO26 Clutch Coupling shown

Typical Applications of Clutches & Brakes

- Packaging Machinery
- Medical Equipment
- Conveyors
- Postal Sorters/Readers
- Document Feeders
- Textile Equipment
- Mobile Power Equipment
- Copiers/Printers

Generating the Clutch or Brake Torque

Inertia Dynamics clutches and brakes are designed to start and stop inertial loads when the voltage is turned on. When DC voltage is applied to the coil, the magnetic force caused by the magnetic flux pulls the armature across the air gap against the force of the zero-backlash spring attached to the armature. The mating of the armature and rotor face produce torque.

When DC voltage is interrupted, the magnetic field collapses, and the zero-backlash spring retracts the armature from the rotor face. There is no residual torque produced.

Special Features of the IDI Clutches and Brakes

- Precision oilite sleeve and ball bearings for long life.
- Zero-backlash armature assembly providing a spring release for reliable and precise disengagement.
- Stationary field coil assembly means no slip rings or brushes.
- All parts effectively protected against corrosion. Asbestos-free friction material.
- Non-standard coil voltages available upon request.
- Metric bore sizes available.
- Conforms to ROHS standards.