

SO Series Clutch Couplings

Instruction Manual

P-8157-IDI
040-10152

Diagram 1

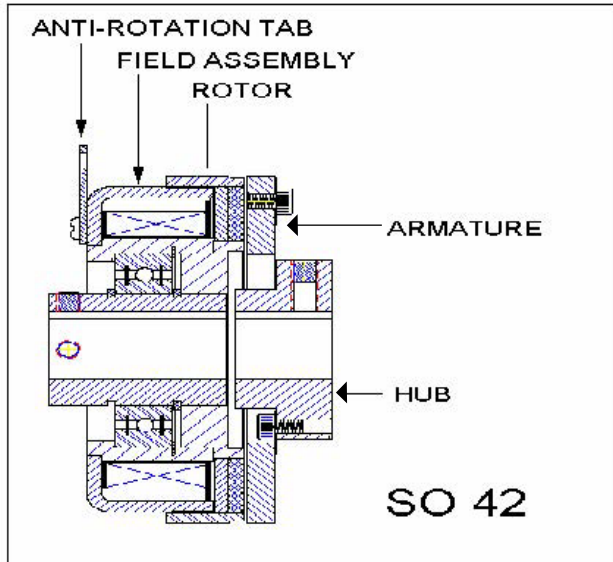

SO series power-on clutch couplings are used to couple two in line shafts. The rotor and field assembly is mounted on a shaft with the field assembly retained from rotating with a loose fitting pin or bracket through the anti-rotation tab (see diagram 1). All parts should be examined for damage from shipping and handling prior to assembly. Measurements should be taken to insure parts meet application requirements, such as shaft fits, coil voltages, etc. All parts must be clean and free of any foreign material before attempting assembly.

Note: Do not hi-pot clutches with AC operating voltages as that will damage the internal rectifier.

Chart 1

Imperial		Metric	
Set Screw Size	Recommended Tightening Torque	Set Screw Size	Recommended Tightening Torque
#4	5 in-lbs.	M3	1.13 Nm
#5	9.5 in-lbs.	M4	2.67 Nm
#6	9.5 in-lbs.	M5	5.31 Nm
#8	19.4 in-lbs.	M6	9.10 Nm
#10	33.5 in-lbs.		
1/4"	78.0 in-lbs.		

1. The two in-line shafts must be concentric to each other within 0.005" (0.13mm) total indicated reading (T.I.R.). Angular alignment must be within 0.5 degrees.
2. Install keys (if applicable). Keys should fit keyseat with a tight fit on the sides and slight clearance over the key.
3. Slide the rotor and field assembly onto the shaft and tighten the set screws in the rotor to the recommended torque - see above chart 1.
4. Pin the anti-rotation tab on the field assembly with a loose fitting pin.
5. Slide the armature assembly onto the shaft. Position the shafts and assemblies to achieve a normal operating air gap of .005" to .020" (0.13-0.15 mm). Tighten the set screws in the hub to the recommended torque (see chart 1).
6. Wire the two leads or screw terminals to the power supply. Inertia Dynamics power supplies are available with a wiring diagram showing the proper electrical connections.

Note: After the unit has operated for a short period to time, recheck the air gap, set screws, etc.

Burnishing Procedure

SO clutches are not pre-burnished and may require a "run in" period to develop rated torque. Burnishing is a wearing or mating process that insures rated torque and consistent engagement. If the clutch is accelerating a large inertia load or is engaged at high speed; the normal slipping that will occurs at engagement may self burnish the clutch. SO series clutches produce 50%-90% of rated torque un-burnished. Do not prolong burnish beyond a three (3) minute duration. Long burnish time will cause excessive heat build-up at the friction faces resulting in poor performance.

Note: Care must be taken to prevent contamination of the friction faces with oil or dirt particles during the burnishing process. If possible, burnish units in their final application or location to ensure alignment of the mating parts. If units cannot be burnished in the final application, mount units in a test stand observing concentricity, alignment and air gap.

1. Using a filtered DC power supply, energize the unit at 100% of the rated voltage. Then reduce voltage to 30-40% of the rated voltage.
2. Rotate one member of the clutch (rotor or armature) while holding the other member stationary at the proper RPM (see chart 2). De-energize the unit after a three minute forced slip.
3. Measure the static (break away) torque of the unit with both friction members of the clutch stationary, with full rated voltage applied.
4. Static torque of standard clutches after burnishing to the above procedure should be at their catalog rating. If the unit does not meet the catalog rated torque, repeat Step 3 after a cool down period of five (5) minutes, until the unit comes up to the rated torque.

Chart 2

Unit Size	Slip RPM +/- 10%	Imperial Standard Static Torque Rating	Metric Standard Static Torque Rating
8	250	2.5 in-lbs.	0.28 Nm
11	250	6 in-lbs.	0.68 Nm
15	190	10 in-lbs.	1.13 Nm
17	160	15 in-lbs.	1.70 Nm
19	150	25 in-lbs.	2.83 Nm
22	130	50 in-lbs.	5.65 Nm
26	60	80 in-lbs.	9.04 Nm
30	50	125 in-lbs.	14.12 Nm
42	30	250 in-lbs.	28.24 Nm

⚠ WARNING Because of the possible danger to person(s) or property from accidents, which may result from the improper use of products, it is important that correct procedures be followed: Products must be used in accordance with the engineering information specified in the catalog. Proper installation, maintenance and operation procedures must be observed. The instructions in the instruction manuals must be followed. Inspections should be made as necessary to assure safe operation under prevailing conditions. Proper guards and other suitable safety devices or procedures as may be desirable or as may be specified in safety codes should be provided, and are neither provided by Inertia Dynamics nor are the responsibility of Inertia Dynamics.



www.idicb.com

31 Industrial Park Road
New Hartford, CT 06057
860-379-1252
Fax: 800-379-1137