

# Completely Enclosed Continuous Operation CEUHS-Series “M” CECON® Clutches

Service & Installation Instructions

P-1346-4-MC  
BULLETIN C-310M

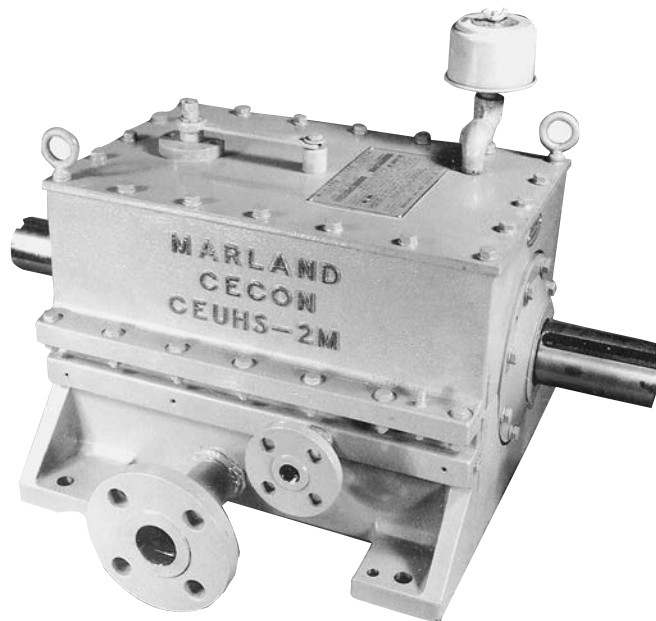

**▲WARNING** Failure to follow these instructions may result in product damage, equipment damage, and serious or fatal injury to personnel.

## Installation, Lubrication, and Maintenance

Shafting is supported on high speed, turbine-type, babbitted bearings (tin base-steel backed). The bearings and clutch must be pressure lubricated with filtered and cooled turbine oil from an external system furnished by customer.

### General

Marland CECON Clutches are designed for continuous operation 24 hours a day for a whole year or longer, if required. Since such continuous operation is directly influenced by the care observed in installation, lubrication, and maintenance, it is important that the following recommendations be used as the basis for proper care of CECON Clutch units.

Failure to comply with these recommendations cancels all warranties since the safety of the unit may be endangered by improper installation or operating procedures.

As soon as the unit has been received, examine it carefully for damage in transit and report any breakage discovered to the transit company at once.

All tags and bulletins attached to the unit should be carefully read before placing the unit in operation and then filed for future reference.

**▲CAUTION** Care must be taken not to place the unit in operation until it has been filled with oil. See "Lubrication". The unit must be supplied with pressure lubrication before starting, during operation, and while coasting to stop.

The various component parts referred to in this bulletin may be readily identified on CEUHS Diagram and Parts List.

### Electrical Grounding

Tapped holes are provided for electrical grounding of the unit. Contact Marland for the optional electrical grounding kit.

### Storage

CECON Clutch units have been coated internally with a preservative oil to protect the internal working parts from corrosion during shipment and a preparation period of not more than one week after arrival at the site before the unit is placed in regular operation. It is not necessary to flush out the preservative oil from the CECON housing, as this oil will be diluted by introduction of the regular oil supply.

The shaft ends and couplings have also been coated with a preservative oil. Do not wash this protective coating from shaft ends or couplings.

If the unit is to be stored for a period of time, properly protected facilities must be provided. To prevent corrosion of the unit due to internal condensation, immediately fill the clutch housing halfway with clean turbine oil of the grade specified on nameplate. To fill, remove the 1/2" square head pipe plug from the inspection cover (Part No. 8) and pour oil through this opening. Keep dirt and contaminants from entering housing. Replace pipe plug. To keep the unit air-tight, do not install the breather-filter. Be sure to rotate shafts at least once every two weeks with sufficient speed to coat all internal surfaces. At time of installation, drain the oil and proceed with the installation per the instructions which follow.

If the unit is to be immediately installed and operated upon its arrival at the site, proceed with the installation as per the instructions that follow.

### Foundations

Care should be taken in the selection of flexible foundations such as light steel or timber structures as they may produce damaging effects.

A rigid foundation such as a reinforced concrete bed or substantial steel structure is recommended. The top of the foundation should be flat to prevent housing distortion. If the CECON unit is to be mounted on a concrete foundation, a steel base plate containing the foot mounting bolts should first be anchored to the foundation.

### Installation

Two eyebolts are provided on the clutch housing. These are to be used when moving, lifting, and lowering the CECON unit into position.

**▲CAUTION** CECON units should never be handled by placing slings or chains around the shaft extensions.

#### A. Direction of Rotation

The CECON unit output shaft (Part No. 26) must be arranged for freewheeling rotation. The nameplate attached to the clutch housing end plate identifies the output shaft. This shaft is to be connected to the shaft of the driven equipment.

The CECON unit input shaft (Part No. 12) is also identified by nameplate on the clutch housing. The input shaft is at the same end of the CECON unit as the hand friction brake (Part No. 4). This shaft is to be connected to the shaft of the driving equipment.

As a further precaution before proceeding with the assembly, check the direction of freewheeling rotation by holding the CECON input shaft (Part No. 12) stationary while trying to rotate the output shaft (Part No. 26) first in one direction and then in the opposite.

**▲CAUTION** Be sure the free rotation is in the desired direction.

#### B. Alignment

We recommend that the coupling hubs and sleeves for the CECON unit shafts be sent to our factory for mounting.

The babbitted bearings can be damaged by improper mounting of the couplings. Accurate alignment of the CECON unit shafts with the shafts of the connected equipment is most important and should be done in accordance with the coupling manufacturer's instructions. The CECON clutch unit shafting is supported on high speed, turbine-type, pressure lubricated, babbitted bearings. The bearings will not tolerate thrust loading from the axial movement of external elements when clearances are reduced in excess of the slide capacity of the couplings, or combined loading resulting from shaft misalignment in excess of coupling operating alignment limits. Misalignment may develop unnecessary overloads and stresses in shafts and bearings, and can be responsible for failure of the equipment. If Marland Clutch has furnished the couplings, see Coupling Data Sheet enclosed with this bulletin. Shaft gaps must be maintained per coupling manufacturer's recommendation.

CECON Clutch unit shafts should be connected to the driving and driven equipment shafts through suitable sizes of double-engagement, self-aligning, gear-type flexible couplings. Do not use couplings of pin, flexible spring, or single-engagement types without the approval of Marland Clutch. In high speed applications, dynamically balanced couplings should be used. Consult with coupling manufacturer.

Never use heavy blows on CECON unit shafts when aligning, mounting hubs, fitting keys, etc. Evidence of damage caused by disregard of these instructions is readily traceable, and Marland Clutch will not be held responsible for the failure of the affected part or parts.

After the CECON has been lowered in place, it is desirable to use metal shims to obtain proper alignment of the CECON unit shafts with the shafts of the driving and driven equipment. Locate housing axially to provide shaft gaps per coupling manufacturer or as shown on the certified drawing. Use shims under feet of housing, preferably U-shaped, to fit around mounting bolts evenly. Check with a feeler gauge to make sure that all pads are supported. Tapped through holes for Jacking Screws are provided to assist in the installation of the metal shims.

Failure to properly shim the CECON unit housing feet may cause the housing to distort when the mounting bolts are tightened.

For inclined applications, refer to the certified drawing for the approved inclined longitudinal mounting axis. The transverse axis must be placed in a horizontal position and checked with a spirit level indicator.

It is important that the alignment of the CECON unit shafts with the shafts of the driving and driven equipment be rechecked after the final tightening of the mounting bolts, and before the coupling sleeves are bolted together.

After the installation has been properly aligned, dowel the CECON unit in place by using two dowels, locating them on the same side of the housing. Doweling will preserve the original alignment and proper shaft relationship should it become necessary to remove and reinstall the CECON unit, thus providing every possible precaution against wrong reassembly.

### C. Oil Flanges

Units are shipped with blind flanges covering the inlet (Part No. 18) and drain (Part No. 19) flanges. Remove the bolts and discard the blind flanges. The connected flanges and piping should not exert any force or distortion on the CECON unit flanges or housing from bolt loading, misalignment or thermal expansion and contraction.

The customer is to supply a suitable pressure gauge, mounted as close as possible to the oil inlet flange, as an indicator that pressure lubrication is being supplied.

The customer is responsible for selecting gaskets for the mating flanges of dimensions and materials capable of withstanding the required bolt loading without injurious crushing, and suitable for service conditions in all other respects. Care must be taken that the gaskets do not restrict the oil flow in any manner.

Customer's oil pressure supply line is to be connected to the CECON unit oil inlet flange (Part No. 18).

A gravity oil drain line must be connected to the drain flange (Part No. 19). An unrestricted, free oil flow must be maintained to prevent oil build-up in the CECON housing.

Before placing in operation, flush a continuous oil supply, to the inlet flange (Part No. 18) of the CECON unit, with the following lubricant specifications:

- Regular turbine oil of approximately 150 to 250 S.S.U. at 100°F.
- 15 to 20 P.S.I. oil pressure at the inlet flange.
- Maximum inlet oil temperature of 110°F.
- Oil filtered to 10 to 15 microns.
- The quantity of oil flow shown in Lubrication Table.

Any changes in lubricant specifications must be approved by Marland Clutch and will be noted on the nameplate and certified drawings.

This continuous pressure lubricant must be supplied **before starting, during operation, and while coasting to stop.**

A gravity oil drain line must be connected to the drain flange (Part No. 19). An unrestricted, free oil flow must be maintained to prevent oil build-up in the CECON housing.

During operation the CECON unit inlet oil pressure should be maintained between 15 to 20 P.S.I. The absolute minimum is 10 P.S.I., but only for short durations at low speeds. Do not operate at pressures above 25 P.S.I. The housing may fill with oil, depending upon speed, direction of rotation, and other variables.

If an oil cooler is required, it should be capable of dissipating a temperature differential of approximately 40°F. between inlet and outlet oil, when the CECON unit is driving at maximum rated speed.

To obtain long, trouble-free service from CECON unit, it is necessary that lubricating oil supplied to the housing be filtered clean and free from dirt particles and sludge at all times. Make frequent inspections of the condition of the oil by sampling a sufficient quantity from the oil tank and inspecting the filtering system. The frequency with which this is done is an important consideration and can only be determined by individual experience. It is considered desirable to perform this inspection several times at weekly intervals after the unit has been placed in operation. The results of such inspection will dictate the frequency for future inspections which could possibly extend to one month intervals, but in any event should not exceed three months. The unit

### Lubrication

#### A. Clutch Unit

Oil containing high lubricity or EP additives must not be used in clutch units. Never use grease for internal lubrication of the clutch. The use of improper lubricants could cause a malfunction resulting in equipment damage.

**Lubrication Table**

CECON Clutch CEUHS Type	Oil Flow Supply (Gallons/Minute)
1M	2-1/2
2M	3-1/2
4M	4-1/2
8M	7
12M	9
18M	11
30M	14
42M	18
60M	23

must not be in operation when cleaning or changing filters or oil supply. Impurities or interruption in oil flow can damage the babbitted bearings and clutch unit; impurities can also plug the oil flow passages.

### B. Breather-Filter

Install the breather-filter. CECON unit will not drain properly if un-vented. Remove the 1/2" square head pipe plug from inspection cover (Part No. 8) and insert the breather filter, using elbow fittings furnished. The breather-filter should be cleaned at regular intervals. The frequency of such servicing depends upon the operating environment and degree of contamination.

### C. Couplings

Lubricate couplings connecting CECON unit input and output shafts to the driving and driven shafts in accordance with the coupling manufacturer's instructions. If Marland Clutch has furnished the couplings, see Coupling Data Sheet enclosed with this bulletin.

## Starting

During initial start-up check the lubricant for cleanliness, adequacy of supply, and proper drainage from the housing. The CECON unit should not be subjected to any induced dynamic vibration. Check for evidence of vibration from loose mountings or foundations, misalignment or connecting shafts, or out-of-balance connected equipment. Check for evidence of localized heating. Localized heat generation could be an indication of contamination in the oil distribution system, damage to the CECON unit during installation, or severe misalignment of the connecting shaft. If any correction is necessary, it should be made before placing the CECON unit into continuous operation.

## Hand Friction Brake

The hand friction brake assembly is located on the input shaft side of the CECON unit. In a dual drive arrangement, where the freewheeling drag torque of the CECON unit is greater than the static frictional drag torque of the connected driving machinery at the CECON input shaft, the hand brake may be used to keep this connected equipment stationary when power is supplied to the system by the alternate driver. The hand brake may also be used to gradually brake and stop the coasting driving machinery at the CECON input shaft when power has been cut and transferred to the alternate driver in the system.

**▲CAUTION** The hand brake must be released before starting the alternate driver.

**▲CAUTION** The friction hand brake is not intended for use as a positive stop to prevent shaft and connected equipment rotation during installation or maintenance.

In shipment and during normal operation of the CECON unit, the brake is locked open against the clutch housing and secured by a small bolt passing through a hole in the end of the handle and retainer. To engage the brake, remove the small bolt and move the handle approximately 90 degrees until pressure is felt against the hand.

**▲CAUTION** Apply hand pressure only. Do not extend the handle length with a pipe or other means as damage may occur to the unit.

## Service

Field disassembly and repair of CECON Clutch is not recommended. Should problems occur, contact Marland Clutch directly.

If the unit is inactive after installation for a prolonged period of time, supply pressure lubrication for a short duration at frequent intervals (at least once every week) to coat all the internal surfaces.

**▲CAUTION** Rotating equipment is potentially dangerous and could cause injury or damage if not properly protected. Follow applicable codes and regulations.

**CEUHS Diagram**

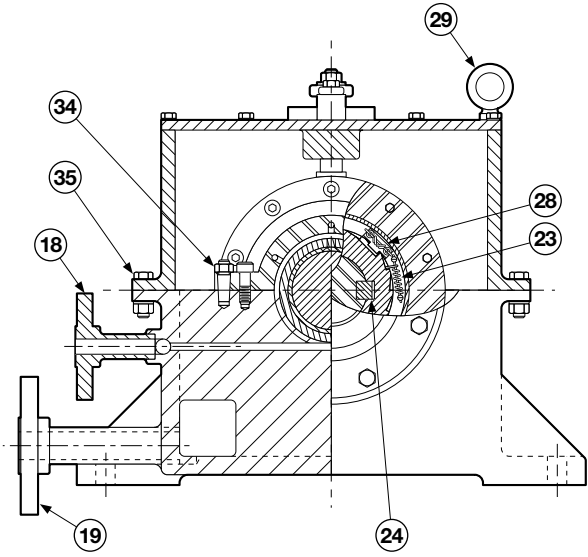
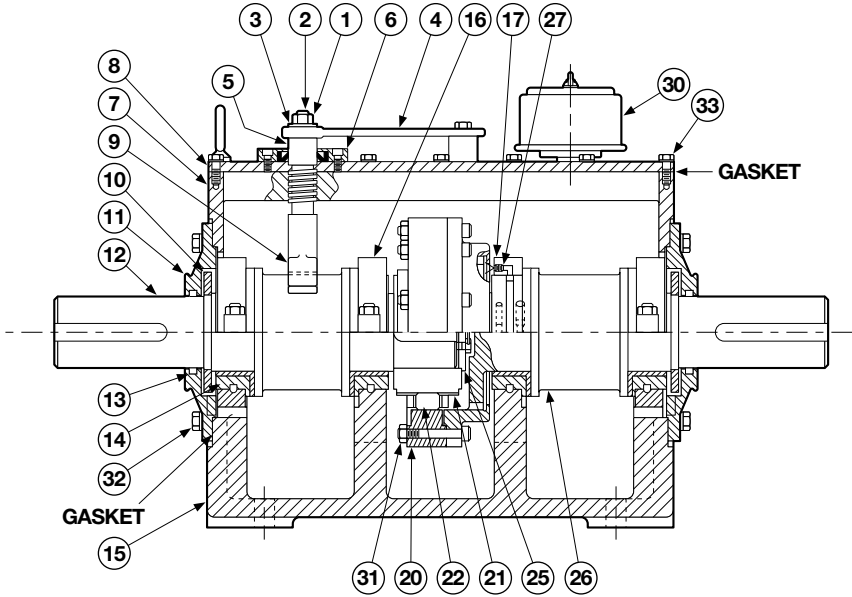

<b>Part #</b>	<b>Description</b>
1	Brake Stud Nut
2	Brake Stud
3	Brake Stud Washer
4	Brake Handle
5	Brake Thrust Screw
6	Brake Seal Cover & Seal
7	Clutch Housing Cover
8	Inspection Cover
9	Brake Shoe
10	Oil Slinger
11	Packing Seal Cover & Gasket
12	Input Shaft
13	Shaft Packing
14	Shaft Bearing & Fasteners
15	Clutch Housing
16	Bearing Cap
17	Bearing Cap with Oil Flow
18	Oil Inlet Flange

<b>Part #</b>	<b>Description</b>
19	Oil Drain Flange
20	Clutch Outer Race
21	Clutch Cam
22	Clutch Roller Assembly
23	Clutch Spring
24	Clutch Cam Key
25	Cam Retainer & Fasteners
26	Flanged Output Shaft
27	Oil Flow Plug
28	Stop Lug
29	Eye Bolt
30	Breather Filter
31	Fasteners for 20
32	Fasteners for 11
33	Fasteners for 8
34	Fasteners for 16 & 17
35	Fasteners for 7

## Warranty

Marland Clutch warrants that it will repair or replace (whichever it deems advisable) any product manufactured and sold by it which proves to be defective in material or workmanship within a period of three (3) years from date of shipment. This warranty extends only to the original purchaser and is not transferable or assignable without Marland Clutch's prior consent.

This warranty covers normal use and does not cover damage or defect which results from alteration, accident, neglect, or improper installation, operation, or maintenance.

Marland Clutch's obligation under this warranty is limited to the repair or replacement of the defective product and in no event shall Marland Clutch be liable for consequential, indirect or incidental damages of any kind incurred by reasons of manufacture, sale or use of any defective product. Marland Clutch either assumes nor authorizes any other person to give any other warranty or to assume any other obligation or liability on its behalf.



[www.marland.com](http://www.marland.com)

23601 Hoover Rd.  
Warren, MI. 48089  
800-216-3515