

Tooth Clutches

Series 5H and 55H-P



Features

- Tooth clutch gives positive drive with no slip
- Shielded bearings need no lubrication in service
- Stationary cylinder allows simple supply connection
- Spring disengagement results in no drag torque other than the rolling resistance of the drive flange/hub bearing
- Standard fixing holes provided in the drive flange
- No axial thrusts transmitted to adjacent components

Series 55H-P Advantages

- All concentricities are controlled within the clutch simplifying installation
- Pilot mount can be used to attach pulleys, sprockets and other drive components simplifying assembly

Series 5H and 55H-P Pressure Applied Tooth Clutch

Stationary Cylinder for Dry Operation or in Oil

Series 5H pressure-applied stationary cylinder tooth clutches can be used dry or in oil. Pressure supply feeds into cylinder via a flexible tube. Piston and cylinder sub-assembly mounts on shielded ball bearings. Positive disengagement achieved by use of release springs separating two toothed components. Drive flange is supported on hub by a shielded ball bearing.

Series 55H-P clutches developed from the Series 5H, incorporate a pilot mount. Pilot mount is supported on an extended hub by a rigid shielded double bearing assembly. Pulleys, sprockets and other drive components can fit directly to pilot mount, which has a toleranced spigot diameter for location and tapped fixing holes.

Typical Applications

- Machine Tool
- Printing
- Tire Making Machines
- Auxiliary and Back-up Drives
- Steel Production, Processing and Machining
- Dynamometers

Tooth Clutches

Series 5H and 55H-P

MODEL		5H30	5H35	5H40	5H45	5H50	5H60	5H70	5H80	—
		55H30P	55H35P	55H40P	55H45P	55H50P	55H60P	55H70P	55H80P	55H90P
Performance Data										
Rated Static Torque at 5.5 bar/80 psi	Nm	160	260	380	550	750	1300	2070	3800	5800
	ft-lbs	115	185	275	395	545	945	1500	2800	4300
Pressure to Overcome Release Springs	bar	1.4	1.4	1.0	0.9	0.8	0.6	0.8	0.6	0.8
	psi	20	20	14	13	12	9	12	9	12
Maximum Speed	revs/min	6000	5040	4800	4000	3840	3200	2720	2560	1920
Performance Data										
A		115	127	134	153	167	193	216	240	280
B		35	45	45	60	65	75	85	100	120
Lengths										
L		79	82	85	93	95	108	123	139	—
M		77	81	83	92	94	106	122	138	—
N		93	98	101	112	113	129	146	165	185
P Engaged		20	21	20	20	21	25	26	27	30
P Disengaged		17	18	17	18	18	22	23	24	28
Q Engaged		38	39	39	40	45	53	58	59	66
5H Drive Flange										
R		111	124	137	150	162	194	213	242	—
S (J6)		62	75	75	95	100	115	130	150	—
T		3.3	2.7	3.0	3.0	3.3	3.0	7.1	6.7	—
U		13	14	14	14	18	18	21	25	—
Fixing Holes	Number of holes	3	3	3	6	6	6	6	6	—
	Size	M6	M6	M6	M6	M8	M8	M10	M10	—
	P.C.D.	90	110	120	130	140	170	190	220	—
55H-P Pilot Mount										
V		99	115	124	137	153	178	209	240	270
W (h8)		72	88	88	102	112	132	145	179	210
X		19	20	20	23	22	23	32	41	57
Fixing Holes	Number of holes	3	3	3	6	6	6	6	8	6
	Size	M6	M6	M6	M6	M8	M8	M10	M10	M12
	Depth	11.1	12.7	12.7	15.9	15.9	22.2	22.2	18	20
	P.C.D.	88	102	108	120	135	155	180	200	250
Driving Teeth										
Number of Teeth		91	106	122	137	152	183	214	300	270

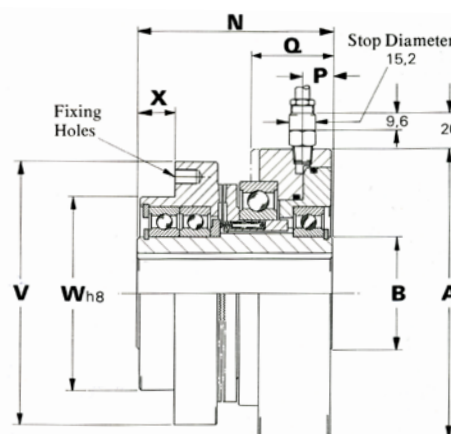
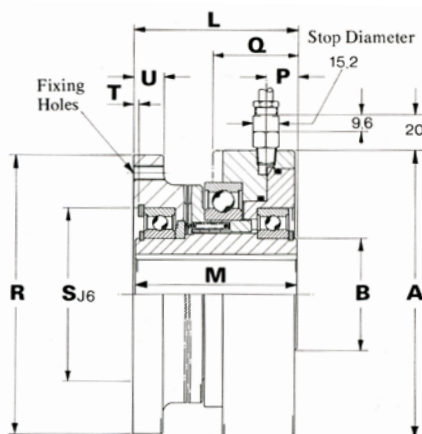

Tooth Clutches

Series 55H-P-SP



Features

- Continuous angular position re-engagement, ensuring drive synchronization
- Tooth clutch provides positive drive with no slip
- All concentricities controlled within clutch simplifying installation
- Sealed bearings need no lubrication in service
- Stationary cylinder allows simple supply connection
- Spring disengagement results in no drag torque other than the rolling resistance of the drive flange/hub bearing
- Standard fixing holes provided in drive flange
- Pilot mount with locating diameter and fixing holes can be used to attach pulleys, sprockets and other drive components simplifying assembly

Series 55H-P-SP Pressure-Applied Single-Position Engagement Pilot-Mount Tooth Clutches

Stationary Cylinder for Dry Operation or in Oil

The 55H-P-SP is a development of the Series 55H-P pilot mount clutch featuring single-position engagement. When the clutch is actuated, the driving and driven sides always engage in the same angular relationship, thus ensuring the driven member is always accurately synchronized. A ball detent feature ensures single-position engagement and the drive is transmitted by toothed rings, giving the same torque ratings as the 55H-P range.

Typical Applications

Industries where synchroized applications are required.

- Printing

Tooth Clutches

Series 5EC-P



Series 5EC-P Sure Drive Electromagnetic Pilot-Mount Tooth Clutches

Stationary Field for Dry Operation

Series 5EC-P electromagnetic tooth clutches are designed for dry operation. When a DC voltage is applied, a magnetic field is generated, bringing the two toothed rings into mesh. This provides a positive slip free drive. The armature is spring-loaded to ensure rapid disengagement and zero drag when disengaged.

Features

- One-piece construction, eliminates costly installation setting and alignment procedures, and ensures all axial forces are contained within the clutch assembly
- Bearing mounted pilot mount, provides rigid precise location for direct attachment of power transmission components and reduces engineering required by machine builder
- 'Hirth' type drive teeth provide high torque in a compact envelope and positive drive without slip
- Stationary coil and magnet assembly allow high running speeds and simple connection to DC power supply without brushes.

Typical Applications

- Machine Tools
- Heavy Machines
- Steel Production, Processing and Machining
- Lifting Gear and Container Cranes
- Synchronization Clutches for series switching of two electric motors
- Dynometers and Test Equipment
- Remotely Operated Equipment
- Metal and Material Handling
- Cardboard Box Machining

Tooth Clutches

Series 5EC-P

MODEL		5EC 025P	5EC 035P	5EC 055P	5EC 070P
Performance Data					
Rated Static Torque	Nm	50	200	800	1800
	lbf ft	37	148	590	1325
Power Consumption at 20° C	Watts	19	26	63	120
Maximum Speed	rpm	5800	4000	3000	2600
Dimensional Data (all dimensions in mm)					
Standard Bores (H7)	—	30	50	60	
Keyways to I.S.O. 773		8 x 3.3	14 x 3.8	18 x 4.4	
B.S. 4235:1972 Pt. 1	20	25	45	55	
D.I.N. 6885:1968 Pt. 1; NFE22-175	6 x 2.8	8 x 3.3	14 x 3.8	16 x 4.3	
(Bores other than standard can be obtained by special order)	15	20	40	50	
	5 x 2.3	6 x 2.8	12 x 3.3	14 x 3.8	
Diameters (all dimensions in mm)					
A		74	98	155	209
B		74	98	153	209
C (h8)		52	75	112	145
D		35	45	75	95
Lengths					
E		77	100	133.5	165
F		15	23	36	46
G (ref)		34.5	34.5	37.2	40
H (ref)		32	32	32	32
J		2.5	2.5	5	6.5
K		8.1	10	10	10
Fixing Holes					
Number		3	3	6	6
Size		M4	M6	M8	M10
P.C.D.		65	88	135	180
Depth		8	12	14	20
Driving Teeth					
Number of Teeth		168	192	264	288

