

GEARHEADS



R16



R40



R32



M22

Portescap

A Danaher Motion Company

Portescap manufactures some of the highest performance miniature gearheads in the industry that are subjected to rigorous quality tests during manufacturing.

With a range of planetary and spur gearheads from 8 mm to 40 mm in diameter, Portescap can offer an entire drive train based on its motor gearbox solutions. Resident experts in gear technology can assemble the gears at Portescap with metal or plastic gears based on an application need.

WHY A GEARHEAD	224
BASIC GEARHEAD OPERATION	225
HOW TO SELECT YOUR GEARHEAD	226
GEARHEAD SPECIFICATIONS	228

MOTION SOLUTIONS THAT MOVE LIFE FORWARD.™



WHY A GEARHEAD



EFFICIENT PERFORMANCE

Every application has power requirements in terms of specific values of speed and torque. With a load demanding high torque at low speed, use of a large motor capable of developing the torque would be uneconomic, and system efficiency would be very low. In such cases, a better solution is to introduce some gearing between the motor and the load. Gearing adapts the motor to the load, be it for speed, torque, or inertia. The motor-and-gearbox assembly will provide greater efficiency and will be an economic solution.

REDUCTION GEARBOXES USING SPUR GEARS

This gear technology offers advantages in current-limited applications where lowest input friction and high efficiency are essential. The broad range of Portescap spur gearboxes is well adapted to our motor lines, and includes integrated gearmotors.

PLANETARY GEARBOXES

The main advantages of Portescap planetary gearboxes are their high rated torque and a high reduction ratio per gear train. Both types use high quality composite materials. The all-metal planetary gearboxes, have a very compact design with excellent performance and lifetime.

GEARHEAD DESIGNATION

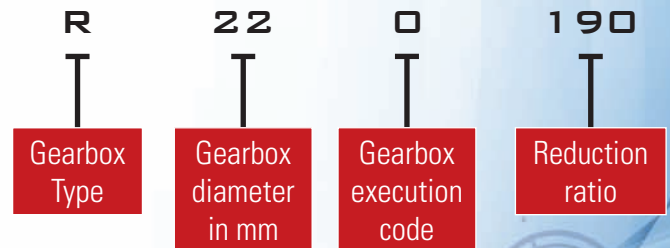

HIGH SPEED PLANETARY GEARBOXES

This high performance product line was designed for use on BLDC motors with iron core windings. The gearboxes tolerate input speeds in the range of 10,000 to 70,000 rpm and output speeds of several 1,000 rpm. This facilitates a motor-gearbox unit of very small dimensions that can provide extremely high values of speed and torque.

BASIC SPUR AND PLANETARY GEARHEAD OPERATION

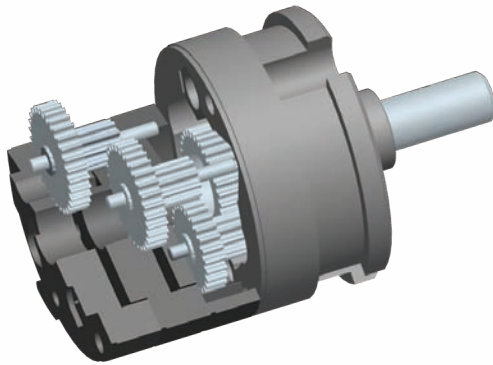

PRINCIPLE OF THE SPUR GEARHEAD:

The pinion of radius r_1 and number of teeth z_1 , drives the input wheel of radius r_2 and number of teeth z_2 .

The reduction ratio per train "i" is $z_2:z_1$ which is equal to $r_2:r_1$.



PRINCIPLE OF THE PLANETARY GEARHEAD:

The pinion S (= sun) having "s" teeth is driving the planets P (3 or 4 per train) which have "p" teeth and are fixed to the planet carrier.

A = stationary annulus with "a" teeth.

The reduction ratio per train is $i = (a:s) + 1$.

Concept Detail	Gearhead Characteristics	Advantages for the Application
Spur gear concept: Only 1 transmission point per train	Low friction per train Arrangement of several trains as intended by the designer Input and output shaft not necessarily in line Two output shafts possible	Good efficiency, about 0.9 per train Long gearhead of small diameter or short gearhead of large diameter Free choice for placing the motor relative to the output shaft Mounting of a sensor, a potentiometer
Input wheel made of high grade plastic generated at high motor speeds	Reduction of mechanical noise	Silent operation
Planetary concept: 3 or 4 transmission points per train	Reduction ratio per train is higher but so is friction Can transmit higher torques Input and output of a train have the same direction of rotation Less backlash	Less trains for a given reduction ratio Efficiencies about 0.85 per train Very compact gearbox for its performance For any number of trains, the load always rotates in the same direction as the motor Smaller shock in case of a paid reversal of motor rotation



HOW TO SELECT YOUR GEARHEAD

In addition to the dynamic output torque, the factors that should be considered when selecting a gearhead to be operated in conjunction with a Portescap motor are defined below:

DIRECTION OF ROTATION

It indicates the direction of the output shaft relative to the motor (= or \neq). In planetary gearboxes, the direction is always the same at input and output, for any number of trains.

EFFICIENCY

It depends mainly on the number of trains. It is an average value, measured at an ambient temperature of 20 to 25°C. A new gearbox has lower values which will reach the normal value after the run-in period.

MAX. STATIC TORQUE

It is the peak torque supported at stall; beyond this limit value the gearbox may be destroyed.

MAX. RECOMMENDED INPUT SPEED

It has a large influence on the noise level and life time of the gearbox and, depending on the application, should be considered when selecting the reduction ratio.

BACKLASH

This is the angle a gearbox output shaft can rotate freely with the input blocked. It is mainly due to gear play necessary to avoid jamming, plus shaft play and the elastic deformation of teeth and shafts under load.

As it is load-dependent, two values are given, with and without a load torque. In fact, backlash of the preceding gear trains appears at the output shaft diminished by the reduction ratio. Contrary to this, output shaft backlash appears at the input multiplied by the ratio. With a 100: 1 ratio, a backlash of 1° represents a rotation of 100° at the input, and at each reversal of the motor, the output only starts rotating once these 100° are caught up.

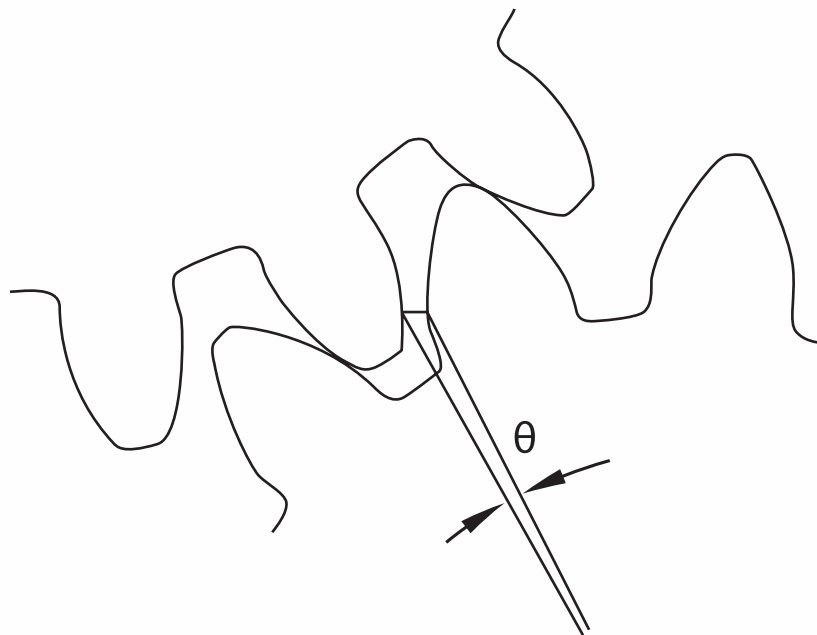

Standard features of a range of Portescap gear heads are given below. Detailed specifications can be found in the catalog page for each of the gearbox.



GEARBOX		R10	R13	B16	BA16
Diameter	mm	10	13	16	16
Length (range)	mm	9 - 26.5	14.5 - 26.8	10.5 - 23	26.7 - 36.7
Ratio (range)	-	4 - 4096	5.5 - 915	5 - 2187	22.5 - 3280.5
Nominal Torque	Nm	0.1	0.25	0.12	0.2
Efficiency (ratio dependent)	-	0.9 - 0.5	0.85 - 0.55	0.81 - 1.48	0.72 - 0.48

GEARBOX		R16	R22	M22	K24	K27
Diameter	mm	16	22	22	24	27
Length (range)	mm	16 - 28.3	25 - 40	22.6 - 50.2	15 - 21	28.5
Ratio (range)	-	5.5 - 915	5.75 - 1090	3.67 - 903.8	5 - 2048	6.2 - 2970
Nominal Torque	Nm	0.3	0.6	1.5	0.17	0.4
Efficiency (ratio dependent)	-	0.85 - 0.55	0.8 - 0.5	0.8 - 0.5	0.85 - 0.65	0.65 - 0.4

GEARBOX		R32	RG1/8	RG1/9	K40	R40
Diameter	mm	32	26.2	26.2	40	40
Length (range)	mm	32 - 50	16.5	17.3	40 - 50	38.3 - 63.8
Ratio (range)	-	5.75 - 1090	5.5 - 3000	4.25 - 1620	5 - 405	3.56 - 753
Nominal Torque	Nm	4.5	0.6	1.2	3	10
Efficiency (ratio dependent)	-	0.8 - 0.55	0.8 - 0.55	0.8 - 0.45	0.8 - 0.55	0.85 - 0.5

