

## Self-Contained Freewheels

# GFR..F1F2, GFR..F2F7 GFRN..F5F6

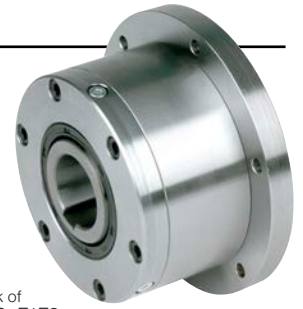

Back of  
GFR..F1F2

### TYPE



GFRN..F5F6

GFR..F2F7

GFR..F1F2

Types GFR..F1F2/F2F7 and GFRN..F5F6 are roller type freewheels, self-contained, sealed and bearing supported, using two 160.. series bearings.

They use the GFR, GFRN base modules described on previous pages. Units must be oil lubricated before use if they are delivered disassembled. Primarily used as overrunning or indexing clutches. The cover combination is chosen according to the type of drive, as shown overleaf. F2 and F6 covers are used to close the unit.

They are equipped with 3 screws for oil filling, drain and level.

The shaft seal is a standard lip seal. Covers may be easily assembled by a qualified user, allowing direction of rotation to be selected on site. Alternatively, units can be delivered assembled and lubricated (except GFRN..F5F6).

# Self-Contained Freewheels

## GFR..F1F2, GFR..F2F7, GFRN..F5F6

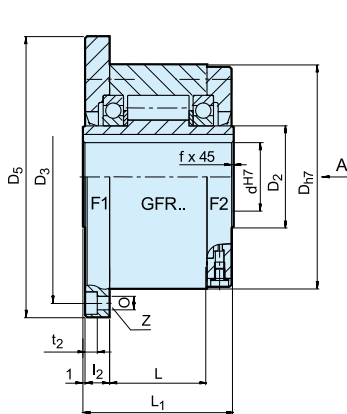

GFR...F1F2

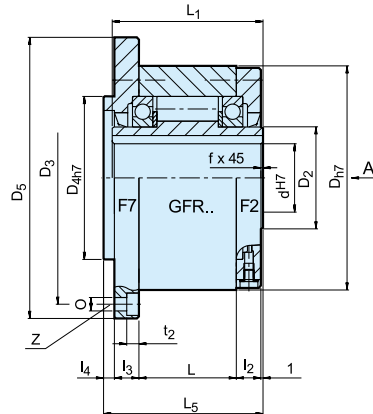

GFR...F2F7

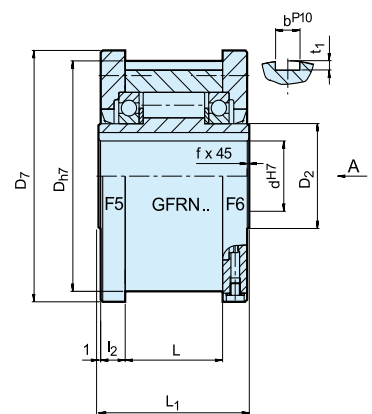

GFRN...F5F6

Type	Size	Overrunning speeds				Number							Keyway outer race							Weight		
GFR..F1F2, GFR..F2F7, GFRN.. F5F6	d <sup>H7</sup> [mm]	T <sub>KN</sub> <sup>1)</sup> [Nm]	n <sub>imax</sub> <sup>2)</sup> [min <sup>-1</sup> ]	n <sub>amax</sub> <sup>3)</sup> [min <sup>-1</sup> ]	D <sub>H7</sub> [mm]	D <sub>5</sub> [mm]	D <sub>7</sub> [mm]	D <sub>3</sub> [mm]	D <sub>4H7</sub> [mm]	0 [mm]	t <sub>2</sub> [mm]	z	L <sub>1</sub> [mm]	L <sub>5</sub> [mm]	L [mm]	I <sub>2</sub> [mm]	I <sub>3</sub> [mm]	I <sub>4</sub> [mm]	t <sub>1</sub> [mm]	b <sup>P10</sup> [mm]	f [mm]	[kg]
	12	55	3100	4700	62	85	70	72	42	5,5	5,7	3	42	44	20	10	10	3	2,5	4	0,5	1,2
	15	125	2800	4400	68	92	76	78	47	5,5	5,7	3	52	54	28	11	11	3	3	5	0,8	1,6
	20	181	2400	4100	75	98	84	85	55	5,5	5,7	4	57	59	34	10,5	10,5	3	3,5	6	0,8	1,9
	25	288	1600	3800	90	118	99	104	68	6,6	6,8	4	60	62	35	11,5	11,5	3	4	8	1,0	2,9
	30	500	1300	2800	100	128	109	114	75	6,6	6,8	6	68	70	43	11,5	11,5	3	4	8	1,0	3,9
	35	725	1200	2600	110	140	119	124	80	6,6	6,8	6	74	76	45	13,5	13	3,5	5	10	1,0	4,9
	40	1025	850	2300	125	160	135	142	90	9	9	6	86	88	53	15,5	15	3,5	5	12	1,5	7,5
	45	1125	740	2200	130	165	140	146	95	9	9	8	86	88	53	15,5	15	3,5	5,5	14	1,5	7,8
	50	2125	580	1950	150	185	160	166	110	9	9	8	94	96	64	14	13	4	5,5	14	1,5	10,8
	55	2625	550	1800	160	204	170	182	115	11	11	8	104	106	66	18	17	4	6	16	2,0	14,0
	60	3500	530	1700	170	214	182	192	125	11	11	10	114	116	78	17	16	4	7	18	2,0	16,8
	70	5750	500	1600	190	234	202	212	140	11	11	10	134	136	95	18,5	17,5	4	7,5	20	2,5	20,8
	80	8500	480	1500	210	254	222	232	160	11	11	10	144	146	100	21	20	4	9	22	2,5	27,0
	90	14500	420	1300	230	278	242	254	180	14	13	10	158	160	115	20,5	19	4,5	9	25	3,0	40,0
	100	20000	310	1100	270	335	282	305	210	18	17,5	10	182	184	120	30	28	5	10	28	3,0	67,0
130	31250	220	900	310	380	322	345	240	18	17,5	12	212	214	152	29	27	5	11	32	3,0	94,0	
150	70000	170	700	400	485	412	445	310	22	21,5	12	246	248	180	32	30	5	12	36	4,0	187,0	

### NOTES

1)  $T_{max} = 2 \times T_{KN}$   
 » Refer to Selection page 7 to 11

2) Inner race overruns

3) Outer race overruns  
 Keyway to DIN 6885.1

When ordered assembled, please specify direction of rotation seen from arrow „A“: „R“ Inner race overruns in clockwise direction „L“ Inner race overruns in counter-clockwise direction

» Refer to mounting and maintenance instructions page 12 to 13

### MOUNTING EXAMPLES

