

Stieber CSK Combined Bearing/Freewheel

The CSK features a compact design well balanced between torque capacity and bearing load.

FEATURES & BENEFITS

- +50 years of CSK product experience
- Formchrome® sprags guarantee long lifetime
- Customization on demand
- Press fit or keyway variants to ensure safe torque transmission
- Available with high quality lip seals
- German engineering excellence
- First class technical support



AT A GLANCE

Types	Applications groups	Type of support	Overrunning Clutch	Indexing Clutch	Backstop	Bore range-diameter mm	Torque range Nm	Overrunning Speed inner race	Overrunning Speed outer race	Lubrication
CSK	Integral bearing/freewheel based on series 62*	Bearing support	●	●	●	8-40	2,5-325	High Speed	High Speed	Grease
CSK..2RS			●	●	●	12-40	9,3-325			
CSK..P. CSK..PP			●	●	●	12-40	9,3-325			
CSK..P-2RS			●	●	●	12-40	9,3-325			

* with exception of 2RS (5mm wider)

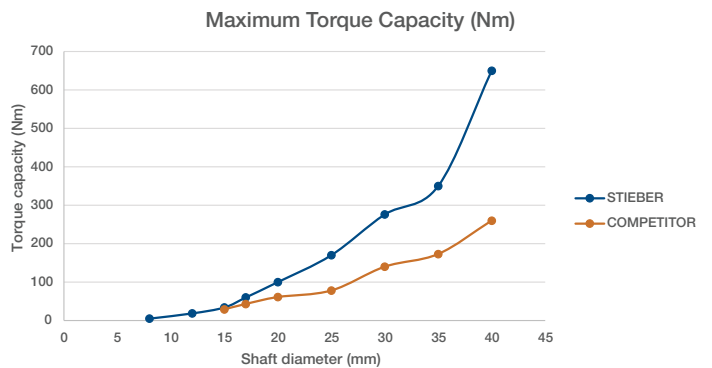
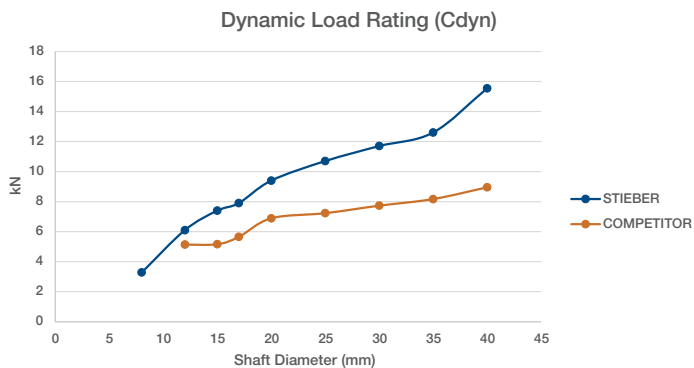

CSK Components from left to right:

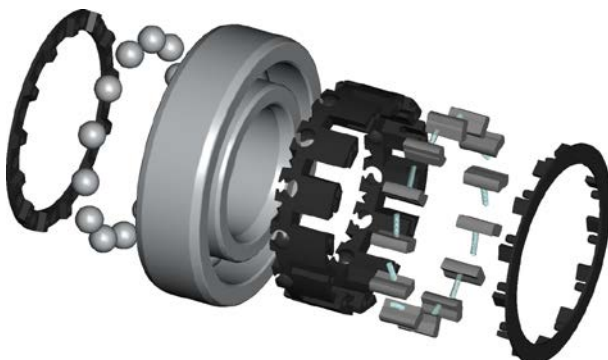

- Cover plate
- Rolling element
- Bearing race
- Cage
- Formchrome® sprags and energising springs
- Cover plate