

Installation and Maintenance Instructions for Freewheels Type AL...G (without cooling fan)

To avoid premature failure of the freewheel or possible machine malfunction, installation of the freewheel should be carried out by suitably qualified personnel and according to the following instructions.

STIEBER will not accept liability in cases of non-compliance with these instructions!

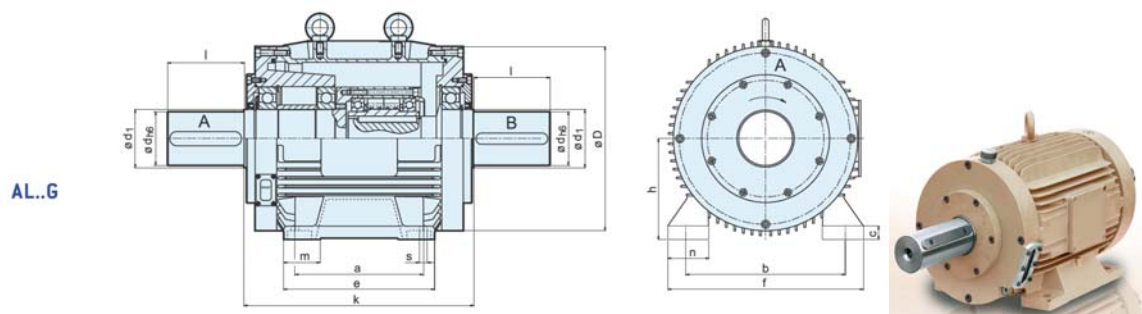

Type	Size	Overrunning Speed shaft A																Weight
		$T_{KN}^{1)}$ [Nm]	n_{max} [min ⁻¹]	d_{hA} [mm]	l [mm]	k [mm]	D [mm]	d_1 [mm]	h [mm]	m [mm]	n [mm]	f [mm]	e [mm]	a [mm]	b [mm]	s [mm]	c [mm]	
AL..G	30-G1	500	5500	38	80	280	194	45	100	33.5	42	200	175	140	160	14	14	50
	50-G3	2125	3400	65	140	430	310	80	160	58	71.5	318	260	210	254	18	22	115
	60-G3	3500	2900	75	140	430	310	80	160	58	71.5	318	260	210	254	18	22	125
	70-G3	5750	2600	75	140	430	310	80	160	58	71.5	318	260	210	254	18	22	138
	80-G4	8500	2400	90	170	510	434	95	225	80.5	92	436	346	286	356	22	30	284
	90-G4	14500	2000	120	170	510	434	130	225	80.5	92	436	346	286	356	22	30	300
	100-G4	20000	1500	120	210	510	434	130	225	80.5	92	436	346	286	356	22	30	330
	120-G5	31250	1300	120	210	800	610	140	315	100	131	620	550	457	508	30	46	980
	150-G5	70000	1200	160	250	800	610	190	315	100	131	620	550	457	508	30	46	1100

Mounting

The freewheel must always be installed in a way that shaft „A“ is connected to the output and shaft „B“ to the input side of rotation and torque.

Overrunning always has to be effected by shaft „A“ .

Before mounting check the freewheels correct direction of rotation and compare it with the indications. Hold shaft “B” and at the same time rotate “A”. Shaft “A” has to go free only in the intended direction.

If the equipment is to be painted entirely sides „A“ and „B“ are to be marked with distinction.

Safe anchorage of the freewheel to the ground plate must be ensured. For securing 4 screws (quality 10.9) have to be used.

The shaft ends on the freewheel have to be cleaned carefully and grease lubricated before mounting coupling halves. These parts can be mounted easier onto the shaft when they are warmed up to 100°C by help of an oil bath or similar means.

Alignment of the encased freewheel

Careful and exact alignment will increase considerably the lifetime of the freewheel. Parallel and angular misalignment of the entire power transmission line have to be kept as low as possible. Account for misalignments by longitudinal thermal expansion.

Lubrication and Maintenance

Oil inlet screw, Oil drain screw, Breather: Location see appended sample drawing.

Unscrew breather: During filling with oil, air can come out easier.

First Filling with Oil

The encased freewheel is delivered without oil. Before starting the freewheel fill it with multigrade oil SAE10W-40 or any oil according to table below (quantity see table below).

Fill in oil up to the marking in the oil sight glass. Screw in again the oil inlet screw and tighten it. The level at operating temperature should be in the range of the marking in the oil sight glass. Operating temperature is reached about 3 hours after starting. Before starting operation please check seat and tightness of inlet- and drain screw.

Avoid to overfill the freewheel and check the oil level frequently!

Change of Oil

After 8000 hours or one year of operation oil change is required. Before refilling with fresh oil the freewheel must be cleaned by flushing.

Preparation

- Arrange all necessary tools. Don't forget a funnel
- Container for old oil and flushing oil
- Allocate the new oil

Change of the Oil with the standing still freewheel (drive is shutdown)

- Unscrew the oil-inlet screw and the breather
- Unscrew the oil drain screw with seal and drain the oil into a container.
- Close again the oil drain screw and fill in any thin oil or petroleum (quantity see table below).
- Switch on the driving motor (**in torque transmitting mode → both shafts must rotate**)
- Stop the flushing procedure about 2 minutes later by switching off the drive.
- Drain the flushing oil.
- Screw in the oil drain screw with sealing and tighten it.
- Fill in about correct quantity of new oil
- Screw in the oil inlet screw and the breather.
- check- and if necessary- adjust the oil level when operating temperature is reached.

Change of Oil with Freewheel running

This is possible only in torque transmitting mode → both shafts must rotate

CAUTION!! Danger by possible contact between you and fast rotating shafts or couplings

Change the oil with the freewheel running only when no alternative can be found.

The actions that must be done are similar to the actions with the “standing still freewheel” described above.

Draining, flushing and refilling should not last longer than 5 to 8 minutes.

Longtime Conservation and Storage

Inner protection against corrosion

For a planned storage of the freewheel for more than 3, respectively 6 months (depending on the environmental conditions) fill the freewheel completely with oil.

Caution!! Before starting the freewheel after the period of storage reduce the oil to the correct level. Replace the oil if it is older than 1 year.

External Protection against Corrosion

Blank steel surfaces need to be treated regularly with anti-corrosion sprays in more or less long periods depending on the environmental conditions.

Oil Volume Table:

Freewheel Type	Oil Volume [l]
AL 50 - G3	2,5
AL 55 - G3	2,75
AL 60 - G3	2,75
AL 70 - G3	2
AL 80 - G4	6,5
AL 90 - G4	4,75
AL 100 - G4	4,75
AL 120 - G5	25
AL 150 - G5	17

Oil Selection Table:

	Ambient temperature			
	-40°C to -15°C	-15°C to +15°C	+15°C to +30°C	+30°C to +50°C
	Operating temperature			
	-20°C to +20°C	+10°C to +50°C	+40°C to +70°C	+50°C to +85°C
	Oil			
ISO - VG DIN 51519	10	22	46	100
ARAL	SUMOROL CM10	SUMOROL CM22	MOTANOL HK46	DEGOL CL100T
BP	ENERGOL CS10	ENERGOL CS22	ENERGOL CS46	ENERGOL RC100
DEA	ASTRON HL10	ASTRON HL22	ASTRON HL46	ASTRON HL100
ESSO	NUTO H10 SPINESSO 10	NUTO H22 SPINESSO 22	NUTO H46 TERESSO 46	NUTO H100
FUCHS	RENOLIN MR3	RENOLIN DTA22	RENOLIN DTA46	RENOLIN MR30
KLÜBER	CRUCOLAN 10	CRUCOLAN 22	CRUCOLAN 46	CRUCOLAN 100
MOBIL	VELOCITE No6	VELOCITE No10	VACTRA MEDIUM VG46	VACTRA HEAVY VG100
SHELL	MORLINA 10	MORLINA 22	MORLINA 46	MORLINA 100
TOTAL	AZZOLA ZS10	AZZOLA ZS22	AZZOLA ZS46	AZZOLA ZS100
Alternatively we recommend to use multigrade oils SAE10W-40 at working temperature between 0° and 80°C				

