

# L-Jaw Elastomeric Couplings

**F3**

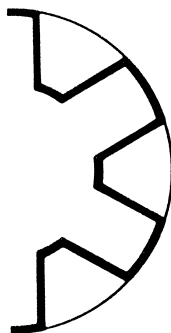

- 100% interchangeable with industry standard
- 3 Insert materials available
- 3 Hub materials available
- Large selection of sizes

# Jaw Couplings

## Selection

### Determine the Prime Mover Classification

| Prime Mover   | Class |
|---|-------|
| • Electric Motors (Standard duty), Hydraulic Motors, Turbines | A     |
| • Gasoline or Steam Engines (4 or more cylinders)             | B     |
| • Diesel or Gas Engines, High Torque Electric Motors          | C     |

### Determine the Load Characteristics and the Service Factor

| Typical Applications  | Load           | Characteristics   | Prime Mover Class |            |            |
|---|----------------|---|-------------------|------------|------------|
|   |                |   | A                 | B          | C          |
| Agitators (pure liquids), Blowers (centrifugal), Can and Bottle Filling Machines, Conveyors - uniformly loaded or fed (belt, chain, screw), Fans (centrifugal), Generators (uniform load), Pumps (centrifugal), Screens (air washing, water), Stokers (uniform load), Woodworking Machines (planers, routers, saws)   | Uniform        | Even loads – no shock – non reversing – infrequent starts (up to 10 per hour) – low starting torques<br>– Up to 8 hours per day<br>– Over 8 hours per day     | 1.0<br>1.5        | 1.5<br>2.0 | 2.0<br>2.5 |
| Beaters, Blowers (lobe, vane), Compressors (centrifugal, rotary), Conveyors - non uniformly loaded or fed (belt, bucket, chain, screw), Dredge Pumps, Fans (forced draft, propeller), Kilns, Paper Mills (calendars, converting machines, conveyors, dryers, mixers, winders), Printing Presses, Pumps (gear, rotary), Shredders, Textile Machinery (dryers, dyers) | Moderate shock | Uneven loads – moderate shock – Infrequent reversing – moderate torques<br>– Up to 8 hours per day<br>– Over 8 hours per day                                  | 1.5<br>2.0        | 2.0<br>2.5 | 2.5<br>3.0 |
| Cranes (bridge, hoist, trolley), Fans (cooling tower), Generators (welding), Hammer Mills, Mills (ball, pebble, rolling, tube, tumbling), Pumps (oil well), Wire Drawing Machines   | Heavy shock    | Uneven loads – heavy shock – frequent starts and stops – high starting torques – high inertia peak loads<br>– Up to 8 hours per day<br>– Over 8 hours per day | 2.0<br>2.5        | 2.5<br>3.0 | 3.0<br>3.5 |

**Note:** The above applications depict generally accepted conditions encountered in industry. Extreme temperatures, abrasive dusts, corrosive liquids/dusts, excessively high starting torques, etc., must be considered as extra heavy shock loads. These conditions will increase service factors. Consult factory for these selections.

### Calculate Design Horsepower or Design Torque

- If Prime Mover is a 1200, 1800, or 3600 RPM motor  
Design HP = Prime Mover HP x Service Factor  
Go to page F3—3 and reference the corresponding motor RPM column
- If Prime Mover is not one of the three speeds listed above  
Design Hp @ 100 RPM = (Primer Mover HP x Service Factor x 100) / Coupling RPM  
Go to page F3—3 and reference HP @ 100 RPM column
- If Using Prime Mover Torque  
Design Torque = Prime Mover Torque x Service Factor  
Go to page F3—3 and reference Torque column

### Coupling Ratings

| Hub                  | Max Bore | Max RPM | Buna-N Spider |                  |              | Urethane Spider |                  |              | Hytre Spider |                  |              |
|----------------------|----------|---------|---------------|------------------|--------------|-----------------|------------------|--------------|--------------|------------------|--------------|
|                      |          |         | Spider        | Torque (in. lbs) | HP @ 100 RPM | Spider          | Torque (in. lbs) | HP @ 100 RPM | Spider       | Torque (in. lbs) | HP @ 100 RPM |
| L035                 | 3/8      | 31000   | L035N         | 3.5              | 0.006        |                 |                  |              |              |                  |              |
| L050, AL050          | 5/8      | 18000   | L050N         | 26               | 0.042        | L050U           | 39               | 0.06         | L050H        | 50               | 0.08         |
| L070, AL070          | 3/4      | 14000   | L070N         | 43               | 0.069        | L070U           | 65               | 0.10         | L070H        | 114              | 0.18         |
| L075, AL075, SS075   | 7/8      | 11000   | L075N         | 90               | 0.14         | L075U           | 135              | 0.21         | L075H        | 227              | 0.36         |
| L090, AL090          | 1        | 9000    | L090N         | 144              | 0.23         | L090U           | 216              | 0.35         | L090H        | 401              | 0.64         |
| L095, AL095, SS095 ① | 1-1/8    | 9000    | L090N         | 194              | 0.31         | L090U           | 291              | 0.47         | L090H        | 561              | 0.89         |
| L099                 | 1-3/16   | 7000    | L099N         | 318              | 0.51         | L099U           | 477              | 0.77         | L099H        | 792              | 1.3          |
| L100, AL100, SS100 ② | 1-7/16 ④ | 7000    | L099N         | 417              | 0.66         | L099U           | 626              | 1.0          | L099H        | 1134             | 1.8          |
| L110, AL110, SS110   | 1-5/8    | 5000    | L110N         | 792              | 1.3          | L110U           | 1188             | 2.0          | L110H        | 2268             | 3.6          |
| L150, AL150, SS150 ③ | 1-7/8    | 5000    | L150N         | 1240             | 2.0          | L150U           | 1860             | 3.0          | L150H        | 3708             | 5.9          |
| L190                 | 2-1/8    | 5000    | L190N         | 1726             | 2.7          | L190U           | 2589             | 4.1          | L190H        | 4680             | 7.4          |
| L225                 | 2-5/8    | 4600    | L225N         | 2340             | 3.7          | L225U           | 3510             | 5.6          | L225H        | 6228             | 9.9          |
| L276                 | 2-7/8    | 4200    | L276N         | 4716             | 7.5          |                 |                  |              |              |                  |              |

① Uses L090 spiders ② Uses L099 spiders ③ AL150 - Use Buna-N spiders only ④ 1-3/8 for AL and SS hubs

### Coupling HP @ RPM

| Hub                  | Spider | Buna-N Spider |      |      | Spider | Urethane Spider |      |      | Spider | Hytre Spider |      |      |
|----------------------|--------|---------------|------|------|--------|-----------------|------|------|--------|--------------|------|------|
|                      |        | HP @ RPM      |      |      |        | HP @ RPM        |      |      |        | HP @ RPM     |      |      |
|                      |        | 1200          | 1800 | 3600 |        | 1200            | 1800 | 3600 |        | 1200         | 1800 | 3600 |
| L035                 | L035N  | 0.07          | 0.10 | 0.20 |        |                 |      |      |        |              |      |      |
| L050, AL050          | L050N  | 0.50          | 0.75 | 1.5  | L050U  | 0.75            | 1.1  | 2.3  | L050H  | 0.95         | 1.4  | 2.9  |
| L070, AL070          | L070N  | 0.8           | 1.2  | 2.5  | L070U  | 1.2             | 1.8  | 3.8  | L070H  | 2.2          | 3.3  | 6.5  |
| L075, AL075, SS075   | L075N  | 1.7           | 2.6  | 5.1  | L075U  | 2.6             | 3.9  | 7.7  | L075H  | 4.3          | 6.5  | 13   |
| L090, AL090          | L090N  | 2.7           | 4.1  | 8.2  | L090U  | 4.0             | 6.2  | 12   | L090H  | 7.6          | 11   | 23   |
| L095, AL095, SS095 ① | L090N  | 3.7           | 5.5  | 11   | L090U  | 5.6             | 8.3  | 17   | L090H  | 11           | 16   | 32   |
| L099                 | L099N  | 6.0           | 9.1  | 18   | L099U  | 9.0             | 14   | 27   | L099H  | 15           | 23   | 45   |
| L100, AL100, SS100 ② | L099N  | 7.9           | 12   | 24   | L099U  | 12              | 18   | 36   | L099H  | 22           | 32   | 65   |
| L110, AL110, SS110   | L110N  | 15            | 23   | 45   | L110U  | 23              | 35   | 68   | L110H  | 43           | 65   | 130  |
| L150, AL150, SS150 ③ | L150N  | 24            | 35   | 71   | L150U  | 36              | 53   | 107  | L150H  | 71           | 106  | 212  |
| L190                 | L190N  | 33            | 49   | 99   | L190U  | 50              | 74   | 149  | L190H  | 89           | 134  | 267  |
| L225                 | L225N  | 45            | 67   | 134  | L225U  | 68              | 101  | 201  | L225H  | 119          | 178  | 356  |
| L276                 | L276N  | 90            | 135  | 269  |        |                 |      |      |        |              |      |      |

### Spider Characteristics

| Characteristics     | Buna-N   | Urethane                  | Hytre                      |
|---------------------|--|---------------------------|----------------------------|
| Oil Resistance      | Good   | Good                      | Excellent                  |
| Chemical Resistance | Poor   | Good                      | Excellent                  |
| Flexibility         | Excellent  | Good                      | Fair                       |
| Temperature Range   | <b>F</b><br>-40 to +212<br><b>C</b><br>-40 to +100 | -30 to +160<br>-35 to +71 | -60 to +250<br>-51 to +121 |
| Torsional Stiffness | Full Soft  | Medium Soft               | Hard                       |
| Avg Shore Hardness  | <b>80A</b>   | <b>90A</b>                | <b>55D</b>                 |
| Max. Misalignment   |  |                           |                            |
| • Angular           | 1°   | 1°                        | 1/2°                       |
| • Parallel          | .015"  | .015"                     | .015"                      |
| Color               | Black  | Blue                      | White                      |

### Order By Component – Example

|                   | Part Number     | Description           |
|-------------------|-----------------|-----------------------|
| <b>Driver Hub</b> | <b>L09958</b>   | L099 x 5/8            |
| <b>Driven Hub</b> | <b>L09912NK</b> | L099 x 1/2 No Keyseat |
| <b>Spider</b>     | <b>L099N</b>    | L099 Buna-N           |

# Stock Bores

## Dimensions

### Stock L-Jaw Inch Hubs

| Bore Size | Bore Designation | L035 | L050 | L070 | L075 | L090 | L095 | L099 | L100 | L110 | L150 | L190 | L225 | L276 |
|-----------|------------------|------|------|------|------|------|------|------|------|------|------|------|------|------|
| 1/8       | 18               | 0    |      |      |      |      |      |      |      |      |      |      |      |      |
| 3/16      | 3/16             | 0    |      |      |      |      |      |      |      |      |      |      |      |      |
| 1/4       | 14               | X    | X    | X    | X    | X    |      |      |      |      |      |      |      |      |
| 5/16      | 5/16             | 0    | 0    | X    | 0    | X    |      |      |      |      |      |      |      |      |
| 3/8       | 38               | X    | X    | X    | X    | X    |      |      |      |      |      |      |      |      |
| 7/16      | 7/16             |      | X    | X    | X    | X    | X    | X    | X    |      |      |      |      |      |
| 1/2       | 12               |      | X    | X    | X    | X    | X    | X    | X    |      |      |      |      |      |
| 9/16      | 9/16             |      | 1    | 1    | X    | 1    | 1    | 1    | X    |      |      |      |      |      |
| 5/8       | 58               |      | X    | X    | 1    | 1    | 1    | 1    | 1    | X    | X    |      |      |      |
| 11/16     | 11/16            |      |      | 1    | 1    | 1    | 1    | 1    | 1    |      |      |      |      |      |
| 3/4       | 34               |      |      | 1    | 1    | X    | 1    | 1    | 1    | 1    | 1    | X    | X    |      |
| 7/8       | 78               |      |      |      | 1    | 1    | 1    | 1    | 1    | 1    | 1    | 1    | 1    | 0    |
| 15/16     | 15/16            |      |      |      |      | 1    | 1    | 1    | 1    | 1    | 1    | 1    | 1    |      |
| 1         | 1                |      |      |      |      | 1    | 1    | 1    | 1    | 1    | 1    | 1    | 1    |      |
| 1-1/16    | 1116             |      |      |      |      |      | 1    |      | 1    | 1    | 1    |      | 1    |      |
| 1-1/8     | 118              |      |      |      |      |      | 1    | 1    | 1    | 1    | 1    | 1    | 1    | 1    |
| 1-3/16    | 1316             |      |      |      |      |      |      | 1    | 1    | 1    | 1    | 1    | 1    |      |
| 1-1/4     | 114              |      |      |      |      |      |      |      | 1    | 1    | 1    | 1    | 1    | 1    |
| 1-5/16    | 1516             |      |      |      |      |      |      |      | 1    | 1    |      |      |      |      |
| 1-3/8     | 138              |      |      |      |      |      |      |      | 1    | 1    | 1    | 1    | 1    | 1    |
| 1-7/16    | 1716             |      |      |      |      |      |      |      | 1    | 1    | 1    | 1    | 1    |      |
| 1-1/2     | 112              |      |      |      |      |      |      |      |      | 1    | 1    | 1    | 1    |      |
| 1-9/16    | 1916             |      |      |      |      |      |      |      |      | 1    | 1    |      | 1    |      |
| 1-5/8     | 158              |      |      |      |      |      |      |      |      | 1    | 1    | 1    | 1    |      |
| 1-11/16   | 11116            |      |      |      |      |      |      |      |      |      | 1    | 1    | 1    |      |
| 1-3/4     | 134              |      |      |      |      |      |      |      |      |      | 1    | 1    | 1    | 1    |
| 1-13/16   | 11316            |      |      |      |      |      |      |      |      |      | 1    |      |      |      |
| 1-7/8     | 178              |      |      |      |      |      |      |      |      |      | 1    | 1    | 1    |      |
| 1-15/16   | 11516            |      |      |      |      |      |      |      |      |      |      | 1    | 1    |      |
| 2         | 2                |      |      |      |      |      |      |      |      |      |      | 1    | 1    | 1    |
| 2-1/8     | 218              |      |      |      |      |      |      |      |      |      |      | 1    | 1    | 1    |
| 2-3/16    | 2316             |      |      |      |      |      |      |      |      |      |      |      | 1    |      |
| 2-1/4     | 214              |      |      |      |      |      |      |      |      |      |      |      | 1    | 1    |
| 2-3/8     | 238              |      |      |      |      |      |      |      |      |      |      |      | 1    |      |
| 2-1/2     | 212              |      |      |      |      |      |      |      |      |      |      |      | 1    | 1    |
| 2-5/8     | 258              |      |      |      |      |      |      |      |      |      |      |      | 1    |      |
| 2-7/8     | 278              |      |      |      |      |      |      |      |      |      |      |      |      | 1    |

0 No Keyseat      1 Standard Keyseat      X No Keyseat or Standard Keyseat

#### Part Number Examples

L095118      L095 x 1-1/8" Hub  
 L07512NK      L075 x 1/2" No Keyseat Hub  
 L09515/16      L095 x 15/16" Hub

#### Bore Tolerances

| Bore Size              | Tolerance |
|------------------------|-----------|
| Up to and including 2" | + .0005"  |
|                        | + .0015"  |
| Over 2"                | + .0005"  |
|                        | + .0020"  |

#### Standard Keyseat Dimensions

| Shaft Diameter   | Width | Depth |
|------------------|-------|-------|
| 1/2 to 9/16      | 1/8   | 1/16  |
| 5/8 to 7/8       | 3/16  | 3/32  |
| 15/16 to 1-1/4   | 1/4   | 1/8   |
| 1-5/16 to 1-3/8  | 5/16  | 5/32  |
| 1-7/16 to 1-3/4  | 3/8   | 3/16  |
| 1-13/16 to 2-1/4 | 1/2   | 1/4   |
| 2-5/16 to 2-3/4  | 5/8   | 5/16  |
| 2-13/16 to 3-1/4 | 3/4   | 3/8   |
| 3-5/16 to 3-3/4  | 7/8   | 7/16  |
| 3-13/16 to 4-1/2 | 1     | 1/2   |
| 4-9/16 to 5-1/2  | 1-1/4 | 5/8   |
| 5-9/16 to 6-1/2  | 1-1/2 | 3/4   |

## Dimensions

### Stock L-Jaw Metric Bore Hubs

| Bore (mm) | Bore Designation | L035 | L050 | L070 | L075 | L090 | L095 | L099 | L100 | L110 | L150 | L190 | L225 |
|-----------|------------------|------|------|------|------|------|------|------|------|------|------|------|------|
| 5         | 5MM              | 0    |      |      |      |      |      |      |      |      |      |      |      |
| 6         | 6MM              | 0    |      |      |      |      |      |      |      |      |      |      |      |
| 7         | 7MM              |      | 0    |      |      |      |      |      |      |      |      |      |      |
| 8         | 8MM              | 0    | 0    | 0    |      |      |      |      |      |      |      |      |      |
| 9         | 9MM              |      | 1    |      |      |      |      |      |      |      |      |      |      |
| 10        | 10MM             |      | X    | 1    |      |      |      |      |      |      |      |      |      |
| 11        | 11MM             |      | 1    |      | 1    |      |      |      |      |      |      |      |      |
| 12        | 12MM             |      | 1    | 1    | 1    | 1    | 1    |      |      |      |      |      |      |
| 14        | 14MM             |      | X    | 1    | 1    | 1    | 1    | 1    | 1    |      |      |      |      |
| 15        | 15MM             |      | 1    | 1    | 1    | 1    | 1    | 1    | 1    |      |      |      |      |
| 16        | 16MM             |      | 1    | 1    | 1    | 1    | 1    | 1    | 1    |      |      |      |      |
| 17        | 17MM             |      |      |      | 1    |      | 1    |      |      |      |      |      |      |
| 18        | 18MM             |      |      |      | 1    | 1    | 1    | 1    | 1    | 1    |      |      |      |
| 19        | 19MM             |      |      | 1    | 1    | 1    | 1    | 1    | 1    | 1    |      |      |      |
| 20        | 20MM             |      |      |      | 1    | 1    | 1    | 1    | 1    | 1    | 1    |      |      |
| 22        | 22MM             |      |      |      | 1    | 1    | 1    | 1    | 1    | 1    |      |      |      |
| 24        | 24MM             |      |      |      |      | 1    | 1    | 1    | 1    | 1    | 1    |      |      |
| 25        | 25MM             |      |      |      |      | 1    | 1    | 1    | 1    | 1    | 1    | 1    |      |
| 28        | 28MM             |      |      |      |      |      | 1    | 1    | 1    | 1    | 1    | 1    |      |
| 30        | 30MM             |      |      |      |      |      |      | 1    | 1    | 1    | 1    | 1    |      |
| 32        | 32MM             |      |      |      |      |      |      |      | 1    | 1    | 1    | 1    | 1    |
| 35        | 35MM             |      |      |      |      |      |      |      | 1    | 1    | 1    | 1    |      |
| 38        | 38MM             |      |      |      |      |      |      |      |      | 1    | 1    | 1    | 1    |
| 40        | 40MM             |      |      |      |      |      |      |      |      | 1    | 1    | 1    | 1    |
| 42        | 42MM             |      |      |      |      |      |      |      |      | 1    | 1    | 1    | 1    |
| 45        | 45MM             |      |      |      |      |      |      |      |      |      | 1    | 1    | 1    |
| 48        | 48MM             |      |      |      |      |      |      |      |      |      | 1    | 1    | 1    |
| 50        | 50MM             |      |      |      |      |      |      |      |      |      |      | 1    | 1    |
| 55        | 55MM             |      |      |      |      |      |      |      |      |      |      |      | 1    |
| 60        | 60MM             |      |      |      |      |      |      |      |      |      |      |      | 1    |
| 65        | 65MM             |      |      |      |      |      |      |      |      |      |      |      | 1    |

0 No Keyseat      1 Standard Keyseat      X No Keyseat or Standard Keyseat

### Stock Aluminum L-Jaw Hubs

| Bore Size | Bore Designation | AL050 | AL070 | AL075 | AL090 | AL095 | AL100 | AL110 | AL150 |
|-----------|------------------|-------|-------|-------|-------|-------|-------|-------|-------|
| 1/4       | 14               | 0     |       |       |       |       |       |       |       |
| 5/16      | 5/16             | 0     |       |       |       |       |       |       |       |
| 3/8       | 38               | 0     |       |       |       |       |       |       |       |
| 7/16      | 7/16             | 0     | 0     |       |       |       |       |       |       |
| 1/2       | 12               | 0     | 0     | X     | 0     | 0     |       |       |       |
| 5/8       | 58               | 0     | 1     | 1     | 1     | 1     |       |       |       |
| 3/4       | 34               |       | 1     | 1     | 1     | 1     | 1     |       |       |
| 7/8       | 78               |       |       | 1     | 1     | 1     | 1     |       |       |
| 1         | 1                |       |       |       | 1     | 1     | 1     | 1     |       |
| 1-1/8     | 118              |       |       |       |       | 1     | 1     | 1     | 1     |
| 1-1/4     | 114              |       |       |       |       |       | 1     | 1     | 1     |
| 1-3/8     | 138              |       |       |       |       |       | 1     | 1     | 1     |
| 1-1/2     | 112              |       |       |       |       |       |       | 1     | 1     |
| 1-5/8     | 158              |       |       |       |       |       |       | 1     | 1     |
| 1-3/4     | 134              |       |       |       |       |       |       |       | 1     |
| 1-7/8     | 178              |       |       |       |       |       |       |       | 1     |

0 No Keyseat      1 Standard Keyseat      X No Keyseat or Standard Keyseat

### Stock Stainless Steel L-Jaw Hubs

| Bore Size | Bore Designation | SS075 | SS095 | SS100 | SS110 | SS150 |
|-----------|------------------|-------|-------|-------|-------|-------|
| 1/4       | 14               | 0     |       |       |       |       |
| 1/2       | 12               | 1     | 1     |       |       |       |
| 5/8       | 58               | 1     | 1     |       |       |       |
| 3/4       | 34               | 1     | 1     | 1     |       |       |
| 7/8       | 78               | 1     | 1     | 1     |       |       |
| 1         | 1                |       | 1     | 1     | 1     | 1     |
| 1-1/8     | 118              |       | 1     | 1     | 1     | 1     |
| 1-3/8     | 138              |       |       | 1     | 1     | 1     |
| 1-1/2     | 112              |       |       |       | 1     | 1     |
| 1-5/8     | 158              |       |       |       | 1     | 1     |
| 1-3/4     | 134              |       |       |       |       | 1     |
| 1-7/8     | 178              |       |       |       |       | 1     |

0 No Keyseat  
1 Standard Keyseat

### Metric Bore Tolerances

| Bore Size  | Tolerance (mm)   |
|------------|------------------|
| 5 to 6mm   | +0.010<br>+0.022 |
| 7 to 10mm  | +0.013<br>+0.028 |
| 11 to 18mm | 0.016<br>+0.034  |
| 19 to 30mm | +0.020<br>+0.041 |
| 32 to 50mm | +0.025<br>+0.050 |
| 55 to 65mm | +0.030<br>+0.060 |

### Metric Keyseat Dimensions

| Shaft Diameter | Width (mm) | Depth (mm) |
|----------------|------------|------------|
| 6mm            | 2          | 1.0        |
| 9 to 10mm      | 3          | 1.4        |
| 11 to 12mm     | 4          | 1.8        |
| 13 to 17mm     | 5          | 2.3        |
| 18 to 22mm     | 6          | 2.8        |
| 23 to 30mm     | 8          | 3.3        |
| 31 to 38mm     | 10         | 3.3        |
| 39 to 44mm     | 12         | 3.3        |
| 45 to 50mm     | 14         | 3.8        |
| 51 to 58mm     | 16         | 4.3        |
| 59 to 65mm     | 18         | 4.4        |

### Part Number Examples

L09924MM      L099 x 24mm Hub  
AL09512NK      AL095 x 1/2" No Keyseat Hub  
SS150178      SS150 x 1-7/8" Hub

# L-Jaw Couplings

## Dimensions

AL, SS, L035 - L150

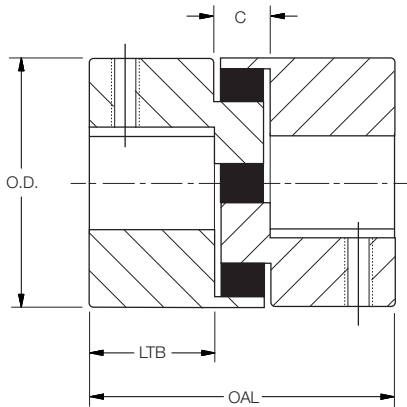

L190 - L276

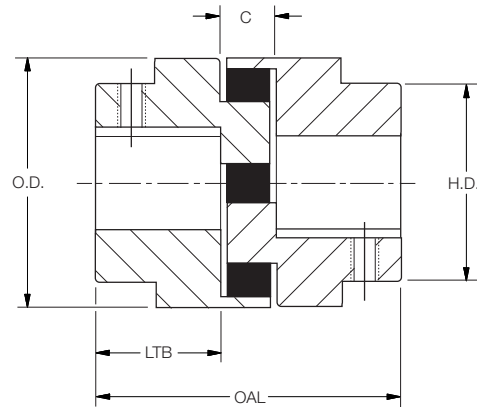

## L-Jaw Dimensions

| Coupling Size      | Hub Material   | Dimensions |      |      |      |      | Weight (Lbs)* |     |      |
|--------------------|----------------|------------|------|------|------|------|---------------|-----|------|
|                    |                | OD         | HD   | LTB  | OAL  | C    | S.I.          | AL  | S.S. |
| L035               | S.I.           | 0.63       |      | 0.27 | 0.81 | 0.28 | 0.1           |     |      |
| L050, AL050        | S.I., AL       | 1.08       |      | 0.63 | 1.72 | 0.47 | 0.3           | 0.1 |      |
| L070, AL070        | S.I., AL       | 1.36       |      | 0.75 | 2.00 | 0.50 | 0.6           | 0.2 |      |
| L075, AL075, SS075 | S.I., AL, S.S. | 1.75       |      | 0.81 | 2.13 | 0.50 | 1.0           | 0.4 | 1.2  |
| L090, AL090        | S.I., AL       | 2.11       |      | 0.81 | 2.13 | 0.50 | 1.5           | 0.6 |      |
| L095, AL095, SS095 | S.I., AL, S.S. | 2.11       |      | 1.00 | 2.50 | 0.50 | 1.8           | 0.7 | 2.2  |
| L099               | S.I.           | 2.53       |      | 1.06 | 2.88 | 0.75 | 2.5           |     |      |
| L100, AL100, SS100 | S.I., AL, S.S. | 2.53       |      | 1.38 | 3.50 | 0.75 | 3.5           | 1.4 | 4.1  |
| L110, AL110, SS110 | S.I., AL, S.S. | 3.33       |      | 1.69 | 4.23 | 0.85 | 6.6           | 3.0 | 8.6  |
| L150, AL150, SS150 | S.I., AL, S.S. | 3.75       |      | 1.75 | 4.50 | 1.00 | 9.1           | 4.2 | 12   |
| L190               | C.I.           | 4.50       | 4.00 | 1.94 | 4.88 | 1.00 | 17            |     |      |
| L225               | C.I.           | 5.00       | 4.25 | 2.19 | 5.38 | 1.00 | 23            |     |      |
| L276               | C.I.           | 6.19       | 5.00 | 3.13 | 7.88 | 1.63 | 47            |     |      |

S.I. = Powdered metal • C.I. = Cast Iron • AL = Aluminum • S.S. = Stainless Steel

\*Weight of coupling with minimum bore hubs