

# Form-Flex® Double Flex Coupling Type AX, All Sizes, All Classes

## Installation & Maintenance Instructions

**P-5005-TBW  
Form 1175**

### Parts List

1. Bolt-short (4)
2. Hub (2)
3. Thin Washer\* (8)
4. Thick Washer (8)
5. Nylon Locking Nut (6)
6. Spacer (1)
7. Flex Disc (2)
8. Set Screw (4)
9. Key (not included)
10. Bolt-long (2)

\* (4) Thin Washers for size 45 & 55

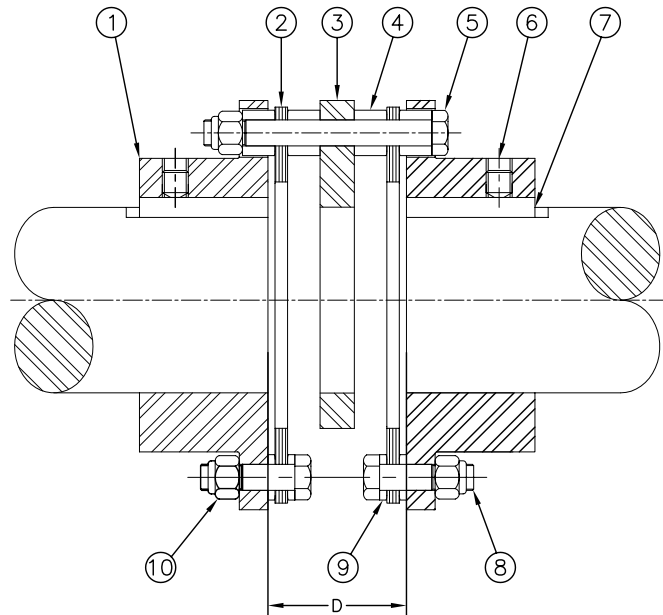

**Figure 1**

Proper care in installing and aligning will permit coupling to operate to full capacity, compensate for angular misalignment, and provide very good service life.

Shafts may become misaligned as a result of many natural and unavoidable causes. Heat, vibration, bearing wear, settling of foundations, etc., all tend to alter initial alignment. To ensure long life, re-check alignment after a short period of actual running.

In general, coupling life is increased when shafts are initially aligned carefully. If this is not done and a coupling is heavily stressed by torque or other forces, it will have little reserve left to accommodate misalignment stresses; and it might not provide the length of service intended. The closer the alignment TIR is to zero, the better the service life of the coupling.

### Installation

1. Inspect shafts and hubs and make sure they are free from burrs.
2. Fit the coupling hubs to the shaft ends. Check for proper fit of the keys to the shafts and hubs.
3. Move the equipment to be connected into position. Set the distance between hub faces to the "D Max" dimension from Table 2. Shaft may protrude through hub, as required, to a "D Min" distance between shafts ends providing the shaft O.D. does not exceed the flex disc I.D. Shaft must not touch the spacer. Tighten the set screws.
4. Assemble the flex disc to the hubs as shown in Figure 2. Tighten these nuts to the proper torque as indicated in Table 1.

**Table 1 - Nut Tightening Torque (Lightly Oiled Threads)**

Size	05	10	15	20	25	30	35	40	45	50	55
FT-LB	8	8	17	17	40	58	58	115	115	160	400

**Table 2 - Dimensional Data**

Size	05	10	15	20	25	30	35	40	45	50	55
D MAX	1.34	1.40	1.54	1.58	2.12	2.54	2.67	3.20	3.55	4.20	5.16
D MIN	0.38	0.44	0.63	0.63	0.75	1.00	1.13	1.13	1.50	1.50	1.75
DISC ID	1.00	1.17	1.28	1.58	1.78	2.01	2.71	3.00	3.51	3.99	4.26

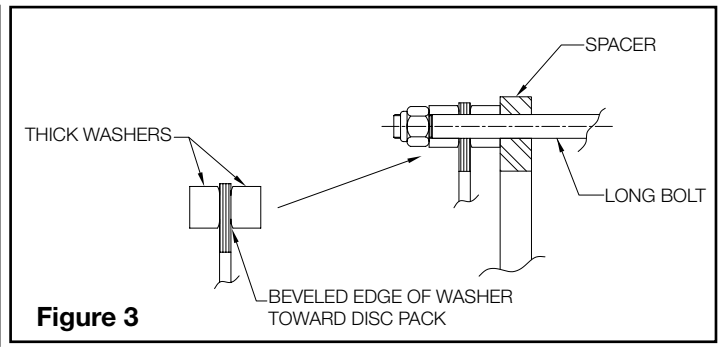
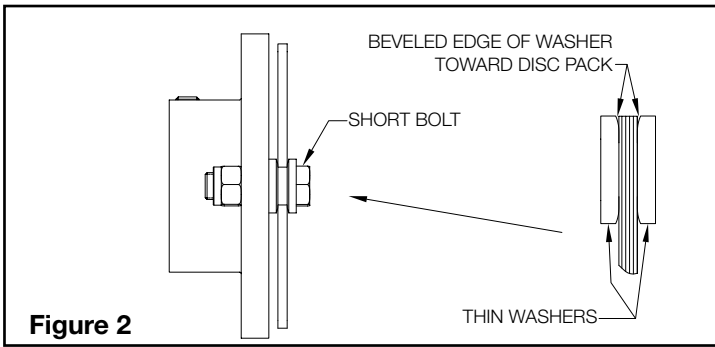

## Alignment

1. Bring the equipment into an approximate good alignment well enough to assemble the spacer and its bolts, washers and nuts. See Figure 3 for proper washer positions.
2. Tighten the nuts to approximately 20 percent of the value in Table 1.
3. Attach a dial indicator to one of the hubs. Indicate a point on the nearest spacer face as close to the edge as possible. See Figure 4.
4. Rotate the coupling 360° to locate the minimum reading on the dial, then rotate the body or face of the indicator so that the zero reading lines up with the pointer.
5. Rotate the coupling 360° while watching the indicator for misalignment readings. The driver and driven equipment will be aligned when the maximum indicator readings are within the allowable limits as shown in Table 3. Adjust the equipment as necessary to comply with the limits. TIR should be as close to zero as possible. Readings should not exceed those shown in Table 3. Repeat for both ends of coupling.

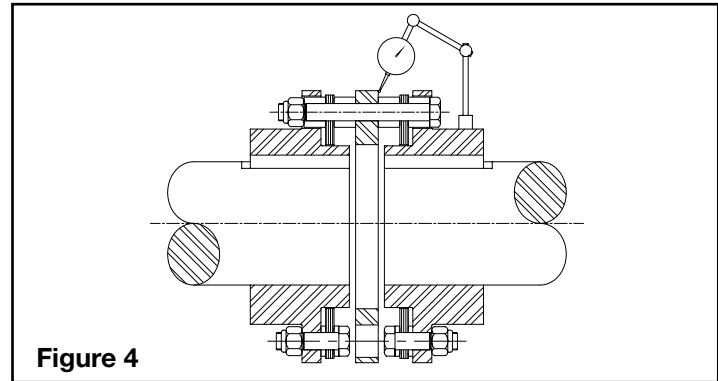

Notes: When the equipment is properly aligned, it is advisable to dowel a right angle gear box to its base. Experience has shown that right angle gear boxes tend to creep in a counter rotational direction. Recheck alignment after dowing.

6. After alignment is proper, tighten the spacer nuts to the value indicated in Table 1.
7. With equipment aligned and coupling assembled, make sure all bolts and washers are in the proper orientation. The curved face of the washer must face the flex disc as shown in Figures 2 and 3.

**Important:** To ensure long life, re-check alignment after a short period (one to two hours) of actual running. At this time also re-torque the nuts to values in Table 1.

**Table 3 - Total Indicator Reading, Maximum; Inches**

Size	05	10	15	20	25	30	35	40	45	50	55
T.I.R.*	.020	.024	.028	.032	.038	.044	.052	.060	.066	.076	.086

\* Equivalent to .50° per flex disc. Lower T.I.R. Readings will provide better alignment of shafts and longer service life.

NOTE: The closer to zero misalignment the better the service that can be expected.

### REPLACEMENT PARTS

To order replacement parts it is necessary to furnish the complete part number(s) and the required part(s). Order must be placed with your distributor.

### ⚠ WARNING

ROTATING EQUIPMENT IS POTENTIALLY DANGEROUS AND MUST BE PROPERLY GUARDED. THE USER SHOULD COMPLY WITH APPLICABLE SAFETY CODES IN ACCORDANCE TO OSHA STANDARDS.

**⚠ WARNING: Cancer and Reproductive Harm - [www.P65Warnings.ca.gov](http://www.P65Warnings.ca.gov)**



[www.tbwoods.com](http://www.tbwoods.com)

2000 Clovis Barker Road  
San Marcos, TX 78666  
512-353-4000