

Disc-O-Torque Hydraulic Clutches D2 & D3

Installation & Maintenance Manual

P-5052-TBW
Form 1386



WARNING:

Rotating equipment must be properly guarded.

It is the responsibility of the user to properly guard all rotating equipment to comply with OSHA or any applicable regulations. Failure to properly guard may contribute to severe injury should someone come in contact with the rotating parts or should the rotating part fail.

WARNING: DO NOT use Wood's products on any primary aircraft drive or any other drive which could endanger human life should a drive component fail.

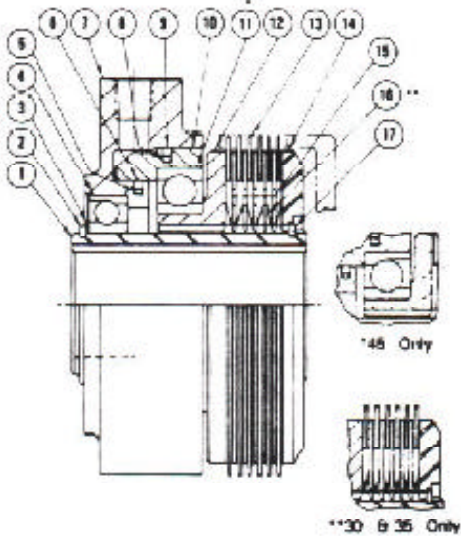

Rebuild Kits					
Disc Kit D2xxDK		Seal Kit D2xxSK		Bearing Kit *** D2xxBK or D3xxBK	
Item	Description	Item	Description	Item	Description
13	Friction Disc	9	Outer Piston Ring	4	Cylinder Bearing
15	Separator Disc	6	Inner Piston Ring	11	Piston Bearing
16	Separator Spring	8	Outer O-Ring	2	Snap Ring
17	Snap Ring	5	Inner O-Ring	3	Shim(s)
*** D2 and D3 are made of the same parts, except for bearings. All kits can be called out by the D2 number except bearing kits are called out by D2 and D3 prefixes respectively.					
Components not included in rebuild kits.					
Item	Description	Notes			
1	Hub	When and if these parts require replacement, it is usually a sign unseen damage may have occurred to other components in the clutch assembly. It is recommended that the entire clutch assembly be replaced.			
7	Cylinder				
10	Piston				
12	Pressure Plate				
14	Back Plate				

Installation

Friction disc lugs must be slip fit in the drive cup slots. When installing the cup, align lugs and slots carefully. Do not force during assembly; bent lugs will cause the disc to drag.

When installing the clutch, be sure the oil line connection to the clutch is aligned correctly and flexibility or "float" is provided to prevent cocking loads on the clutch bearings.

MAINTENANCE

The Disc-O-Torque clutch, when properly applied and installed, will operate for a long period of time without attention. However, at equipment overhaul time, or when clutch repairs are necessary, all worn parts should be replaced. In addition, all parts subject to cyclic fatigue should be replaced to restore the clutch to "like-new" condition.

Rebuild Kits are available for rebuilding clutches in the field.

HOW TO SELECT AND ORDER THE DISC-O-TORQUE REBUILD KITS:

DISC-O-TORQUE Rebuild Kits can be easily ordered by specifying the proper kit number, series, model number, and bore size of the clutch.

Example: (Seal Kit)	Kit No.	Series	Model No.	Bore
	D245SK	D2	45	1 1/8

NOTE: *Disc Kits and Seal Kits are used for MINOR rebuilds. Bearing Kits will always be used with Disc Kits and Seal Kits for MAJOR rebuilds. It is important to include all above information when ordering the rebuild kit. Neither kit incorporates cylinders, pistons, hubs, pressure plates or back plate. If any of these parts need replacement, the entire assembly should be replaced.*

KITS SHOULD BE OBTAINED FROM THE MANUFACTURER OF THE MACHINE IN WHICH THE CLUTCH IS USED, i.e., THE ORIGINAL EQUIPMENT MANUFACTURER, OR FROM THE LOCAL **TB WOODS** DISTRIBUTOR.

DISASSEMBLY

1. Compress the disc pack by depressing the clutch backplate (14).
2. With the backplate depressed, remove the snap ring (17).
3. Remove friction disc, separator plates and separator springs as a pack (13, 15, & 16). If removing parts individually, note order of assembly.
4. Remove pressure plate (12), piston bearing (11), piston (10), and cylinder (7) from the hub.
5. If any of the above parts are worn, overheated or warped, they should be replaced. Compare each part to a new part to determine degree of wear or distortion.
6. Press the ball bearing (4) from the cylinder (7).
7. Push the cylinder (7) off the piston (10).
8. Check the Teflon seals (6 & 9) and "O" rings (5 & 8) and remove if they are badly worn.
9. If the piston ball bearing is worn and needs replacement, separate the piston (10) and the pressure plate (12). Do not separate these components unless it is necessary to replace parts since the ball bearing could be damaged in the process.

REASSEMBLY

1. Press a new ball bearing (4) into the cylinder, pressing on the outer race of the bearing.
2. Assemble the ball bearing (11) into the piston (10), pressing on the outer race of the bearing.
3. Press the piston and ball bearing onto the pressure plate (12), pressing on the inner race of the bearing.
4. Install the cylinder (7) and ball bearing (4) sub-assembly onto the hub (1).
5. Install the shim (3) and the snap ring (2) onto the hub. Use the same shim originally installed, if it is undamaged.

6. Install the “O” ring (5) and Teflon seal (6) into the cylinder groove. Apply a small amount of oil to assist in assembly. NOTE: Teflon seals must be installed with a proper tool, such as an automotive type piston ring compressor.

7. Place the piston ring compressor over the Teflon seal and tighten. This will compress the Teflon seal to allow installation of the piston.

8. Install the “O” ring (8) and the Teflon seal (9) in the piston groove in the same manner outlined above.

9. With both Teflon seals in position, carefully press the piston into the cylinder. As the piston is started into the cylinder, the chamfer should allow it to slide over the Teflon seal without hanging-up and causing damage. At the same time, the outer Teflon seal must be guided into the cylinder with the fingers or a suitable tool.

NOTE: *Damaged Teflon seals will cause leakage.*

10. Proceed to reassemble the remaining parts of the clutch as illustrated on the parts list. Use shims (3) as necessary to provide proper clearance between discs (13) and separators (15). With proper clearance, discs will be free without excessive play.

11. Install the disc pack (13, 15, & 16).

NOTE: *The splined separator discs should slide freely on the hub.*

12. Install the backplate (14) and snap ring (17). The disc pack must be compressed to install the snap ring.

13. Check clearance between the discs. Discs should be evenly spaced with no evidence of binding.

14. Rotate the hub to make sure it is free in all positions.

All Customer Service phone numbers shown in bold

Belted Drives and Sheaves	Couplings Cont.	Gearing	Linear Products
<p>TB Wood's <i>Belted Drives</i> Chambersburg, PA - USA 1-888-829-6637 – Press #5 <i>For application assistance:</i> <i>1-888-829-6637 – Press #7</i></p>	<p>TB Wood's <i>Elastomeric Couplings</i> Chambersburg, PA - USA 1-888-829-6637 – Press #5 <i>For application assistance:</i> <i>1-888-829-6637 – Press #7</i> <i>General Purpose Disc Couplings</i> San Marcos, TX - USA 1-888-449-9439</p>	<p>Bauer Gear Motor <i>Geared Motors</i> Esslingen, Germany +49 (711) 3518-0 Middlesex, NJ - USA 1-732-469-8770</p> <p>Boston Gear <i>Enclosed and Open Gearing, Electrical and Mechanical P.T. Components</i> Charlotte, NC - USA 1-800-825-6544 <i>For application assistance:</i> <i>1-800-816-5608</i></p> <p>Nuttall Gear and Delroyd Worm Gear <i>Worm Gear and Helical Speed Reducers</i> Niagara Falls, NY - USA 1-716-298-4100</p>	<p>Warner Linear <i>Linear Actuators</i> New Hartford, CT - USA 1-800-825-6544 <i>For application assistance:</i> <i>1-800-825-9050</i> Saint Barthélemy d'Anjou, France +33 (0)2 41 21 24 24</p>
<p>Couplings</p> <p>Ameridrives <i>Mill Spindles, Ameriflex, Ameridisc</i> Erie, PA - USA 1-814-480-5000 <i>Gear Couplings</i> San Marcos, TX - USA 1-800-458-0887 <i>Universal Joints, Drive Shafts, Mill Gear Couplings</i> Erie, PA - USA 1-920-593-2444</p> <p>Bibby Turboplex <i>Disc, Gear, Grid Couplings, Overload Clutches</i> Dewsbury, England +44 (0) 1924 460801 Boksburg, South Africa +27(0) 11 918 4270</p> <p>Guardian Couplings <i>Engineered Flywheel Couplings, Engine Housings and Pump Mounts, Flexible Shaft Couplings</i> Michigan City, IN - USA 1-219-874-5248</p> <p>Huco <i>Precision Couplings and Air Motors</i> Hertford, England +44 (0) 1992 501900 Chambersburg, PA - USA 1-888-829-6637</p> <p>Lamiflex Couplings <i>Flexible Couplings, Bearing Isolators, and Coupling Guards</i> Cotia, SP - Brasil +55 (11) 4615-6300</p>	<p>Electromagnetic Clutches and Brakes</p> <p>Inertia Dynamics <i>Spring Set Brakes; Power On and Wrap Spring Clutch/Brakes</i> New Hartford, CT - USA 1-800-800-6445</p> <p>Matrix <i>Electromagnetic Clutches and Brakes, Pressure Operated Clutches and Brakes</i> Brechin, Scotland +44 (0) 1356 602000 New Hartford, CT - USA 1-800-825-6544</p> <p>Warner Electric <i>Electromagnetic Clutches and Brakes</i> New Hartford, CT - USA 1-800-825-6544 <i>For application assistance:</i> <i>1-800-825-9050</i> Saint Barthélemy d'Anjou, France +33 (0)2 41 21 24 24 <i>Precision Electric Coils and Electromagnetic Clutches and Brakes</i> Columbia City, IN - USA 1-260-244-6183</p>	<p>Heavy Duty Clutches and Brakes</p> <p>Industrial Clutch <i>Pneumatic and Oil Immersed Clutches and Brakes</i> Waukesha, WI - USA 1-262-547-3357</p> <p>Svendborg Brakes <i>Industrial Brakes and Brake Systems</i> Vejrstrup, Denmark +45 63 255 255</p> <p>Twiflex <i>Caliper Brakes and Thrusters</i> Wichita Falls, TX - USA 1-844-723-3483 Twickenham, England +44 (0) 20 8894 1161</p> <p>Wichita Clutch <i>Pneumatic Clutches and Brakes</i> Wichita Falls, TX - USA 1-800-964-3262 Bedford, England +44 (0) 1234 350311</p>	<p>Overrunning Clutches</p> <p>Formsprag Clutch <i>Overrunning Clutches and Holdbacks</i> Warren, MI - USA 1-800-348-0881 – Press #1 <i>For application assistance:</i> <i>1-800-348-0881 – Press #2</i></p> <p>Marland Clutch <i>Roller Ramp and Sprag Type Overrunning Clutches and Backstops</i> Warren, MI - USA 1-800-216-3515</p> <p>Stieber Clutch <i>Overrunning Clutches and Holdbacks</i> Heidelberg, Germany +49 (0) 6221-30470</p>
	<p>Engineered Bearing Assemblies</p> <p>Kilian <i>Engineered Bearing Assemblies</i> Syracuse, NY - USA 1-315-432-0700</p>		<p><i>For information concerning our sales offices in Asia Pacific check our website www.altramotion.com.cn</i></p>



www.tbwoods.com

2000 Clovis Barker Road
San Marcos, TX 78666
512-353-4000