

Disc Brake Caliper - Type T2 Air Or Hydraulically Applied

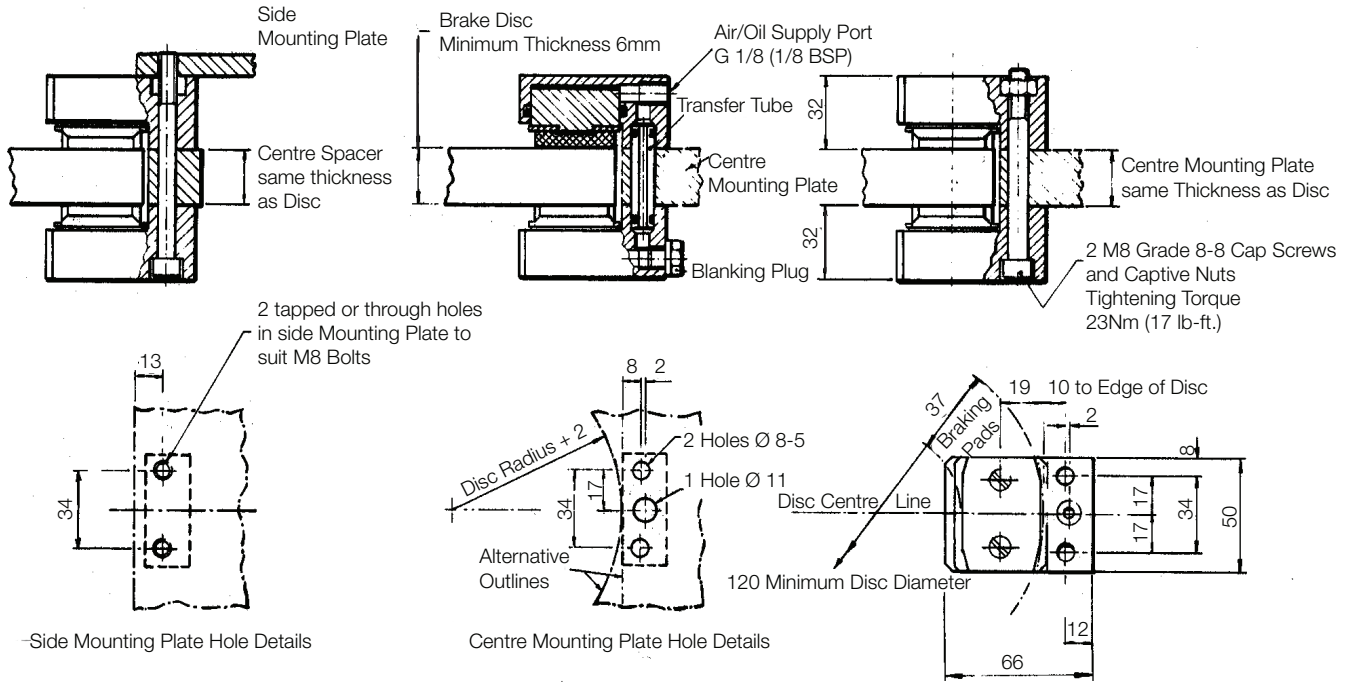

Performance Data

Maximum Braking Force = 2kN @ 20 bar air or oil pressure.
 Braking Force is defined as the Tangential Force acting at the Effective Disc Radius.
 Braking Torque (Nm) = Braking Force (N) x Effective Disc Radius (m)
 where Effective Disc Radius (m) = Actual Disc Radius (m) - 0.019.

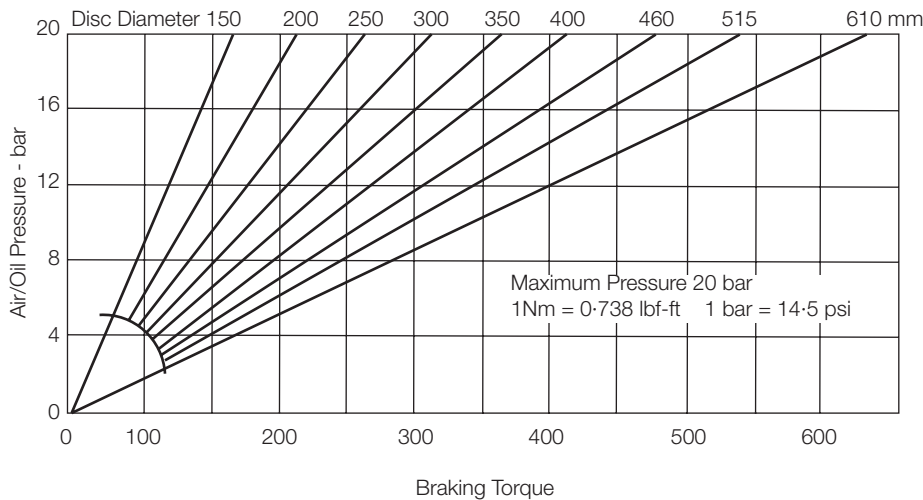

The ratings shown on the above graph are based on fully bedded-in pads.

Technical Data

- Weight - 0.75kg (excluding mounting bolts)
- Pad dimensions - 35 x 50 x 8mm thick (when new)
- Pad friction coefficient - $\mu = 0.4$ (asbestos free material)
- Pad wear allowance - 4mm
- Total pad area - 34cm²
- Hydraulic fluid (mineral) - Shell Tellus 37, Castol Hyspin AWS 32 or equivalent
- Initial Oil filling varies from 2ml (new) to 12ml when pads are fully worn
- Oil displacement per 1mm stroke is 3ml per two caliper halves

Disc Brake Caliper - Type T2 Air Or Hydraulically Applied

General Description

The Twiflex Type T2 disc brake unit is a split caliper design and is adaptable for use on a wide range of disc sizes, varying in thickness from 5mm and over, and in diameter from 120mm and above.

The caliper will normally be mounted on a central mounting plate of the same thickness as the disc; the mounting plate is sandwiched between the caliper halves which are clamped to it by two cap screws M8 grade 12.9, tightened to 23Nm (17 lbf-ft) torque.

Alternatively, the caliper may be secured to a side mounting plate, in which case a spacer of the same thicknesses as the disc is used between the caliper halves.

Standard calipers are available with suitable fixings and transfer tubes to suit various disc thicknesses as follows:

Disc Thickness mm	Standard Caliper Part No. Centre Mounting	Standard Caliper Part No. Side Mounting
5 to 6	6780872/AJ63	6780858/AK49
7 to 8	6780872/AH30	6780858/AH31
9 to 10	6780872/AJ62	6780858/AK35
11.7 to 12.7	6780872	6780858
19 to 20	6780872/AH33	6780858/AH32
24.4 to 25.4	6780872/AH34	6780858/AH21

The basic caliper comprises: 2 caliper halves with brake pads fitted, 1 transfer tube with seals, 1 blanking plug, 2 cap screws, and 2 nuts. A spacer is also supplied for side mounting versions. These units are suitable for use with air or mineral oil based hydraulic fluids.

Calipers for non standard disc thicknesses will be supplied to special order.

Calipers can also be supplied with seals suitable for use with automotive type brake fluids (vegetable oil based) and for extreme temperature applications.

Spares

Friction Pad Kit	Part No. 7080130
Spare Seal Kit (Mineral Oil)	Part No. 6000352 Kit comprising two piston seals and two O-rings.
Spare Seal Kit (Vegetable Oil)	Part No. 6000353 Kit comprising two piston seals and two O-rings.
Pipe Fitting Kit (North America)	Part No. 7300856 Comprising 1 adapter 1/8" BSP (male) to 1/8" NPT (female) and 1 sealing washer

Service

Addresses all enquiries regarding this equipment to your Twiflex agent or directed to Twiflex.