

VCS Series Disc Brakes for Industrial & Marine Applications

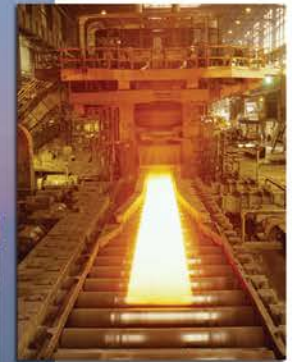

 **Twiflex**[®]
Limited

An Altra Industrial Motion Company

VCS Series Disc Brakes

Application

The VCS Series (modular) disc brake has been specifically designed for both static holding and dynamic (emergency) stopping duty. The braking force is applied by springs located in each module and released by hydraulic pressure. The rate of application and release can be controlled. Depending on the spring pack selected, a maximum braking force of 60kN can be achieved per brake unit. VCS brakes can be used on a wide variety of industrial and marine applications including conveyor drives, hoisting drums, rolling mills, winches, process lines, and cranes.

Description

The VCS Caliper is comprised of two modules located on either side of a mounting plate which could be made to accommodate brake discs of 20mm and over. Each module consists of a spring pack to provide the clamping/braking force. The minimum disc diameter is 500 mm.

Special Features

- Modular construction for easy maintenance and assembly
- Rugged design and corrosion protection for reliable service in challenging operational environments
- Low Pad Pressures
Pad Area = 296.8 cm² (2 Pads)
- Designed for dynamic use with infinite fatigue and exceeding mining standards on stressed parts
- Easy setup and adjustment to precisely tailor to wide ranging operational requirements
- Suitable for “soft braking”
- Wide choice of designs based on standard components
- Backed by a global network of dealers
- Air gap adjustment from rear
- Monitoring sensors for brake on/off and pad adjustment are available

VCSMk4

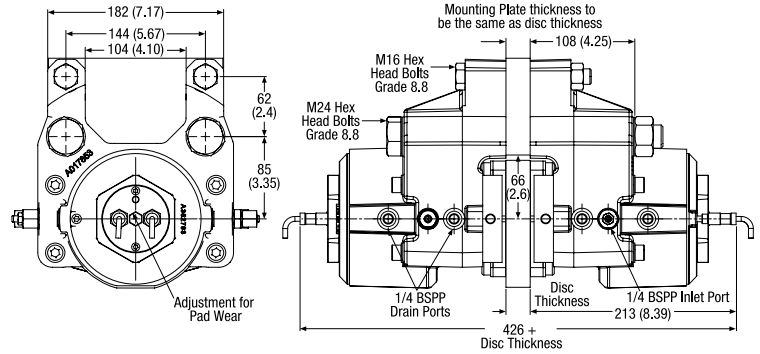

VCS-FL

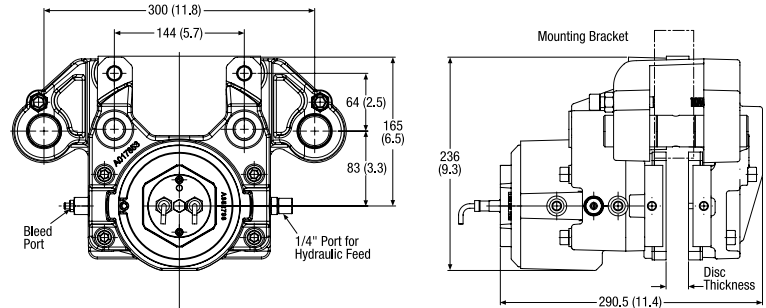

VCS MK4 Spring/Floating Module

Caliper Type	Braking Force kN	Release Pressure bar	Min Pressure for Full Retraction bar	Air Gap in. (mm)
VCS70	62	131	160	.067 (1.7)
VCS60	53	113	148	.079 (2)
VCS50	44	94	131	.079 (2)
VCS40	35	75	113	.079 (2)
VCS30	25	54	94	.079 (2)

Braking forces in the table are at the stated air gap.

Braking force increases with a reduction in air gap setting.

Nominal braking force assumes fully bedded in pads with a coefficient of friction $\mu = 0.4$