

# VKSD Disc Brake Caliper for Industrial & Mining



 **Twiflex**<sup>®</sup>  
Limited

An Altra Industrial Motion Company

# VKSD Disc Brake Caliper

## Description

Designed for the industrial and mining sector, the VKSD and VKSD-VR (large pad) calipers are spring applied, hydraulically released disc brakes which comprise two spring modules located on either side of a mounting plate.

The plate can be made in any thickness to accommodate brake discs of 20mm thickness or over. The minimum disc diameter is 1000mm and there is no maximum.

For high duty and frequent stopping applications the large pad version (VKSD-VR) offers excellent thermal capacity.

With the brake in the “parked off” position, disc spring load and hydraulic pressure are zero, allowing pads to be removed in safety. This feature also permits brake installation without the need for hydraulic pressure.

## Features

Weight (2 modules):	146 kg : 172 kg (VR)
Minimum disc thickness:	20 mm
Working Fluid:	Mineral Oil Based
Maximum operating pressure:	163 bar
Pressure port sizes:	G3/8 (3/8" BSP)
Drain port sizes:	G1/8 (1/8" BSP)
Brake pad area (per pad):	36300 mm <sup>2</sup> : 59976 mm <sup>2</sup> (VR)
Swept brake pad path:	181 mm
Volume displacement per 1mm stroke:	14 ml each module
Working temperature range:	-20°C to 70°C (-40°C optional)
Pad wear allowance:	10mm
Min. disc diameter:	1000 mm
Effective disc radius Re:	Actual radius (m) – 0.095
Braking Torque (Nm):	Braking Force (N) x Re

Floating (Mono Spring) versions available  
Pedestal / Bracket is optional on request

Braking forces in the table are at the stated air gap  
Braking force increases with a reduction in air gap setting.  
Nom. braking force assumes fully bedded in pads  
Coefficient of friction  $\mu = 0.4$

\*Specific pad pressure for large pad version, VKSD-VR

## “Extreme Specifications”

- Stainless Steel Piston, End Cover and Lock Plate
- Stainless Steel fittings and fasteners
- EN Plated Bolts
- External Surfaces Painted to ISO 12944-5:2007 - C5 environment specification.



Scan to View Video  
Benefits of the ‘Parked Off’  
Safety Feature



www.twiflex.com

9 Briar Road, Twickenham  
Middlesex, England TW2 6RB  
Phone: +44 (0) 20 8894 1161  
Fax: +44 (0) 20 8894 6056  
Email: sales@twiflex.co.uk

## VKSD

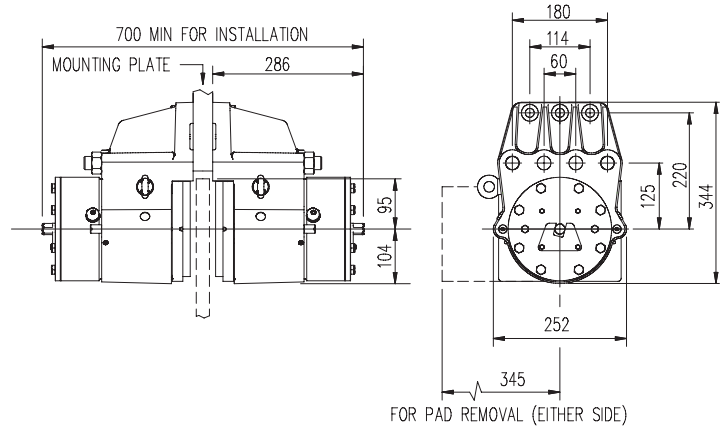

## VKSD-VR

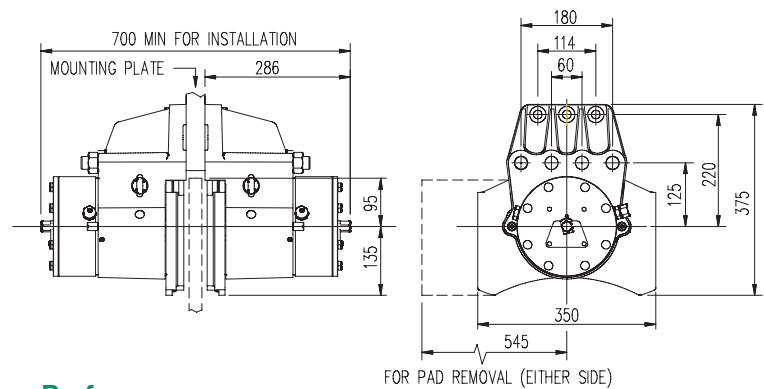

## Performance

VKSD Model	Air Gap (mm)	Braking Force (kN)	Brake Release Pressure (bar)	Full Retraction Pressure (bar)	*Specific Pad Pressure (N/mm <sup>2</sup> )
VKSD119	2	119	124	138	2.48
VKSD112	2	112	116	131	2.33
VKSD104	2	104	108	124	2.17
VKSD96	2	96	100	116	2.00
VKSD88	2	88	92	108	1.83
VKSD80	2	80	83	100	1.67
VKSD71	2	71	75	92	1.48
VKSD62	2	62	65	83	1.29
VKSD58	2	58	58	63	1.21
VKSD53	2	53	53	58	1.10
VKSD47	2	47	47	53	0.98
VKSD41	2	41	41	47	0.85
VKSD34	2	34	34	41	0.71
VKSD28	2	28	28	34	0.58