



Clutch/Brakes for Lawn & Garden Equipment



What makes Warner Electric Clutch/Brakes superior to other brands?

Warner Electric's BBC-II Offers:

- Meets required ANSI/OPEI B71.1 standards
- 2 second blade stop capability
- Proven application through 7 HP / 21" blade diameters
- Two piece subassembly for quick installation
- Bolt which mounts hub to crankshaft is integral to unit
- Available with integral key or keyway
- Disassembles for ease of service
- Heavy-duty for residential and commercial applications
- Assembly/installation time dramatically reduced over competing designs
- No adjustment required
- Zinc/clear dichromate plating improves corrosion resistance

Warner Electric's MagStop® Offers:

- Permanent Magnet Braking System
- Proven application through 37 HP / 96" decks
- 60–250 lb.ft. nominal static torque, depending on the model
- Preassembled — one piece for quick installation
 - "D" drive mounting system provides means for crankshaft restraint while tightening mounting bolt to proper torque
 - Integral key
- Maintenance-free — no adjustment
- Zinc/clear dichromate plating enhances corrosion protection and product appearance

BLADE BRAKE DESIGN

Blade Brake Clutches (BBCs) are engaged by actuating the operator presence lever and pushing the blade engagement handle. This action rotates the ball ramp mechanism, causing three small internal springs inside of the clutch/brake to lift the brake plate clear of the friction disk, assuring drag free, quiet operation. As the brake plate is released from the friction disk, a heavy coil spring at the base of the unit pushes the friction disk against the rotating input hub which is bolted to the engine's crankshaft. The clutch is then engaged and the blade rotates. Releasing the operator presence lever causes the loaded brake spring to rotate the ball ramp mechanism in the opposite direction, which forces the brake plate against the outer portion of the friction disk, releasing the clutch and braking the blade to a stop.

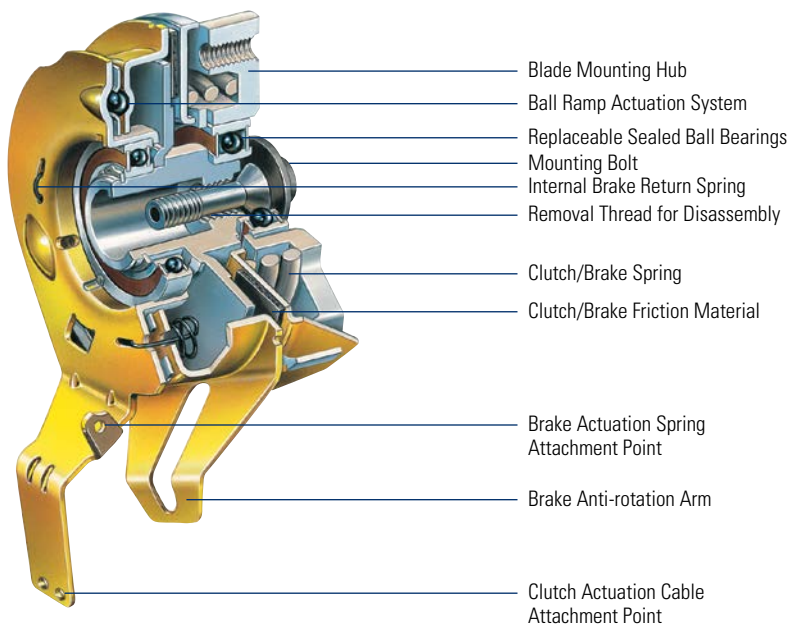

PERMANENT MAGNET DESIGN

The MagStop clutch/brakes combine an electric friction clutch with a permanent magnet brake. Electric current applied to the clutch coil draws the armature to the rotating rotor, engaging the clutch and rotating the blade through the pulley. Stopping current flow to the coil causes the armature leaf springs to pull the backside of the armature (which acts as the braking surface) into contact with the permanent magnet braking surfaces so the braking torque generated by those magnets can stop the blade within three to seven seconds, depending on the application.

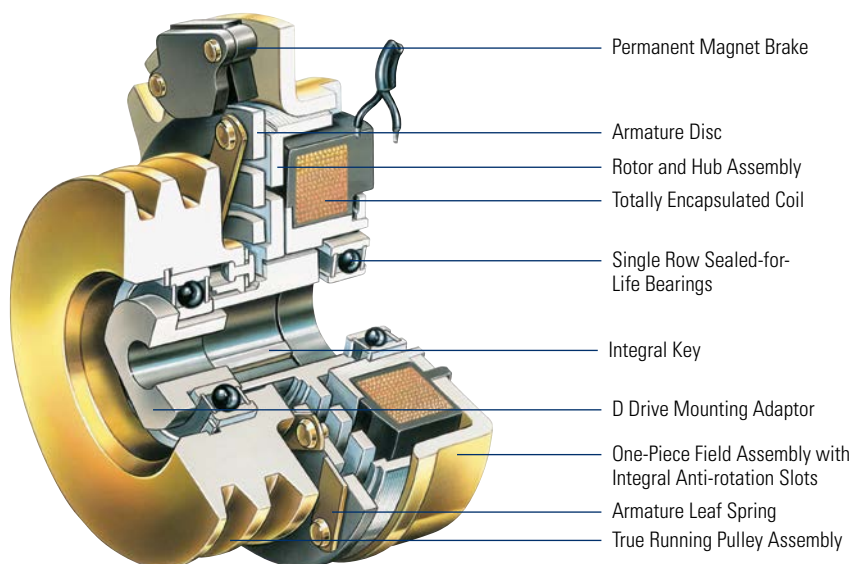

MAINTENANCE-FREE BLADE BRAKE CLUTCHES FOR WALK BEHIND MOWERS

Warner Electric's Blade Brake Clutches (BBCs) are designed to provide operator safety through blade control on walk behind mowers. When the operator presence lever on the mower control handle is released, the BBC brakes the mower blade to a stop within two seconds.

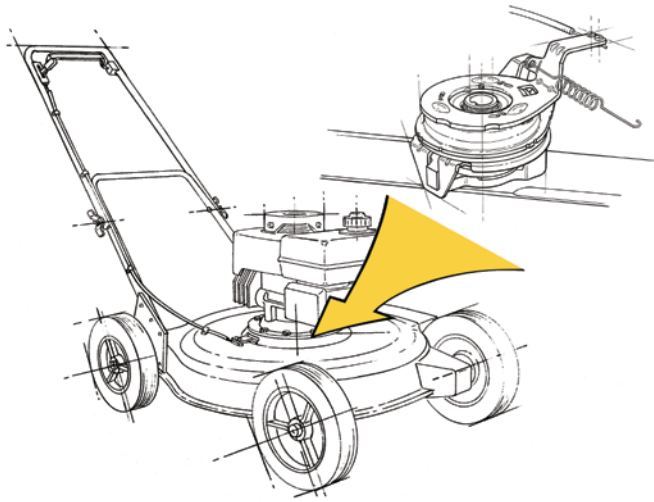

MAGSTOP PTO CLUTCH/ BRAKES FOR RIDING MOWERS PROVIDE ENGINEERED EFFICIENCY

Warner Electric's patented MagStop PTO clutch/brakes combine permanent magnet brake technology with an electric clutch to achieve high torque and maintenance-free operation in a compact package. MagStop is equally at home on either residential or commercial riding mowers with power ratings through 37 HP.

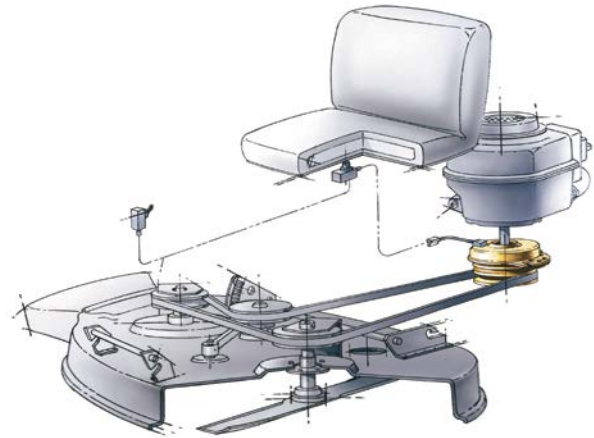

FULL PRODUCT LINE CAPABILITY, CLUTCHES DESIGNED FOR SPECIFIC APPLICATIONS

SERIES NUMBER	SERIES NAME	AVAILABLE TORQUE	CURRENT DRAW RANGE	AVAILABLE BORES*	PULLEY GROOVE AVAILABILITY	EXISTING PULLEY DIAMETERS**	ELECTRICAL CONNECTION	MOUNTING
5217-XX	RMS	60 & 80 ft.lb	1.6 to 3.97 amps	1"	A, A/B, B	5.2 to 7.48"	Integral	Standard & Reverse
5219-XX	TG	105 & 125 ft.lb	3.25 to 4.23 amps	1", 1-1/8"	A, A/B, B, 3V, 5L, 5V, HA	2.893 to 7.3"	Integral & Lead Wire	Standard & Reverse
5218-XX	CMS	175 & 200 ft.lb.	4.85 to 5.53 amps	1", 1-1/8"	A, A/B, B, 3V, 5L, 5V, HA, 8M, GT2	3.35 to 7.345"	Integral & Lead Wire	Standard & Reverse
5228-XX	CMS 250	225 & 250 ft.lb.	6.65 to 6.86 amps	1", 1-1/8", 1-1/4", 1-7/16"	A, A/B, B, C	6.121 to 7.153"	Integral & Lead Wire	Standard & Reverse
5227-XX	GT 300	300 ft.lb.	6.0 to 7.0 amps	1", 1-1/8", 1-1/4", 1-7/16"	A, B, C Flange	4.75 to 9.34"	Screw Terminal	Standard & Reverse

* Other clutch bores may be available depending on application and yearly volume

** Other pulley or flange configurations available depending on application and yearly volume

CMS 250 PERFORMANCE SPECIFICATIONS

LIFE	RMS	
APPLICATION SIZE	ENGINE	Up to 37 HP
	DECK	Commercial applications up to 96" decks Stop deck in less than 7.0 seconds for a minimum of 10,000 cycles
ENVIRONMENT	Ambient – 40°F to +200°F	
	Bearing operating temperatures – 40°F to +350°F	
OPERATING SPEED	Input speeds up to 3600 rpm	
ELECTRICAL SPECIFICATIONS	System voltages of 12.0 to 14.0 volts with a steady state current between 6 to 7 amps	

CMS 250 KEY FEATURES

Integral Key

- Reduced material and labor costs
- Lower Part count
- Full length key to engage with D-drive spacer

D-Drive Spacer

- Lower Part count
- Easier assembly (no loose washer) and removal (for service)

Integral Connector

- Lower cost
- Minimizes clutch damage in case of belt failure
- No chance of ground drive pulley cutting into lead wire

Commercial Mowers



CMS 250 CLUTCH/BRAKES

The CMS 250 Series Commercial MagStop clutch/brakes are designed for heavy-duty mowers with up to 96" decks and engines up to 37 HP. Rugged design for continuous duty and long life.



GT 300 CLUTCH/BRAKES

Featuring a high 300 ft.lb. torque capacity, GT 300 PTO clutch/brakes are rated to 40 HP. Units are simple to install and easy to operate.



COMMERCIAL MAGSTOP CLUTCH/BRAKES

Commercial MagStop clutch/brakes for heavy-duty mowers for large grounds maintenance requirements. Rugged design for continuous duty, long life, and two frame sizes.

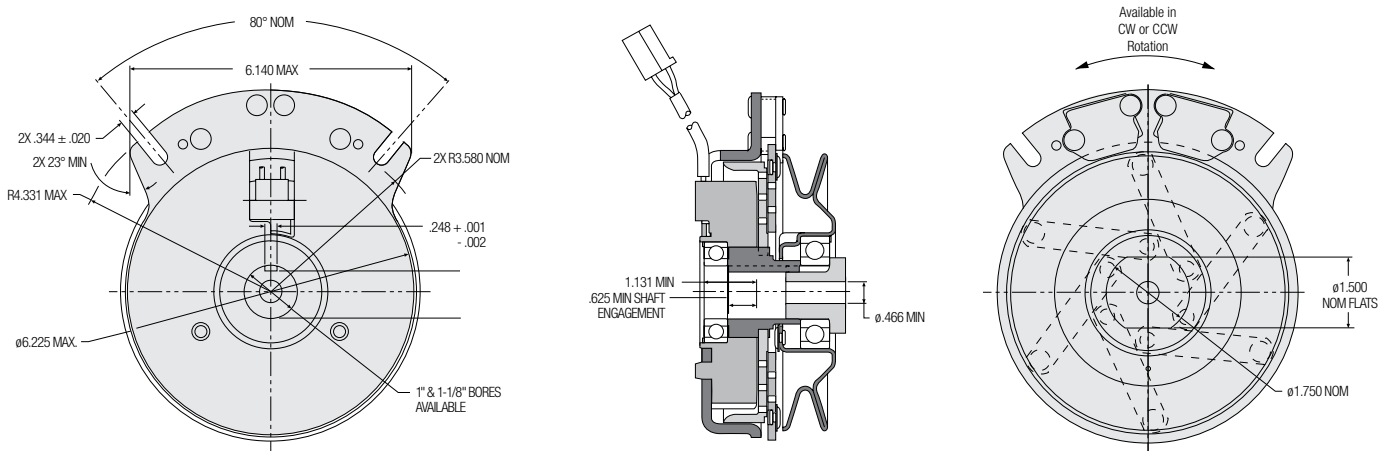
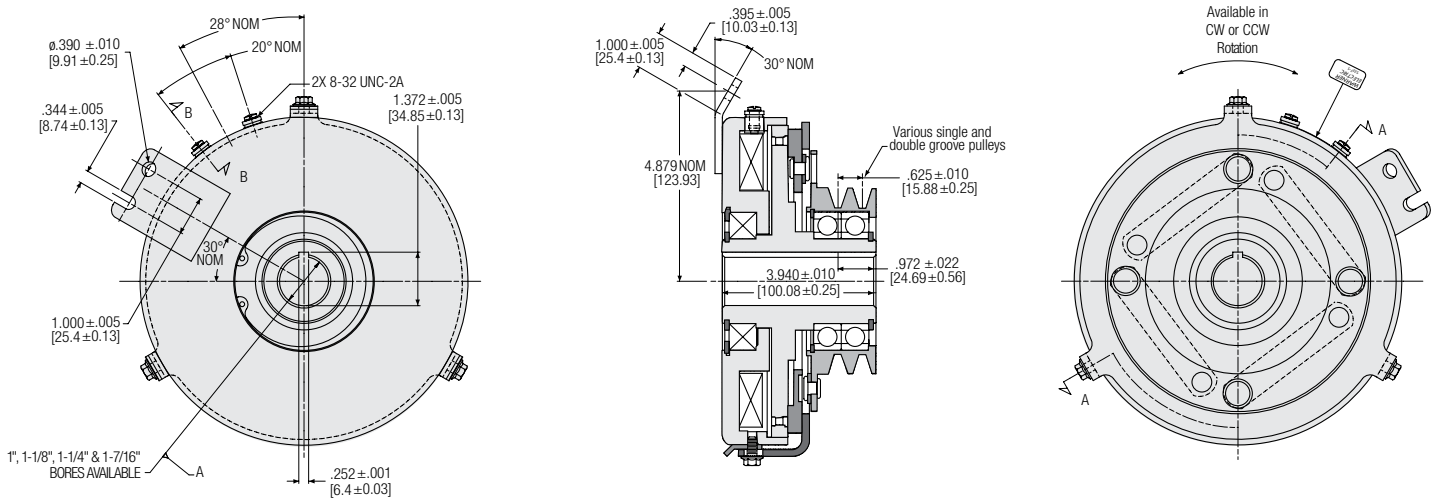
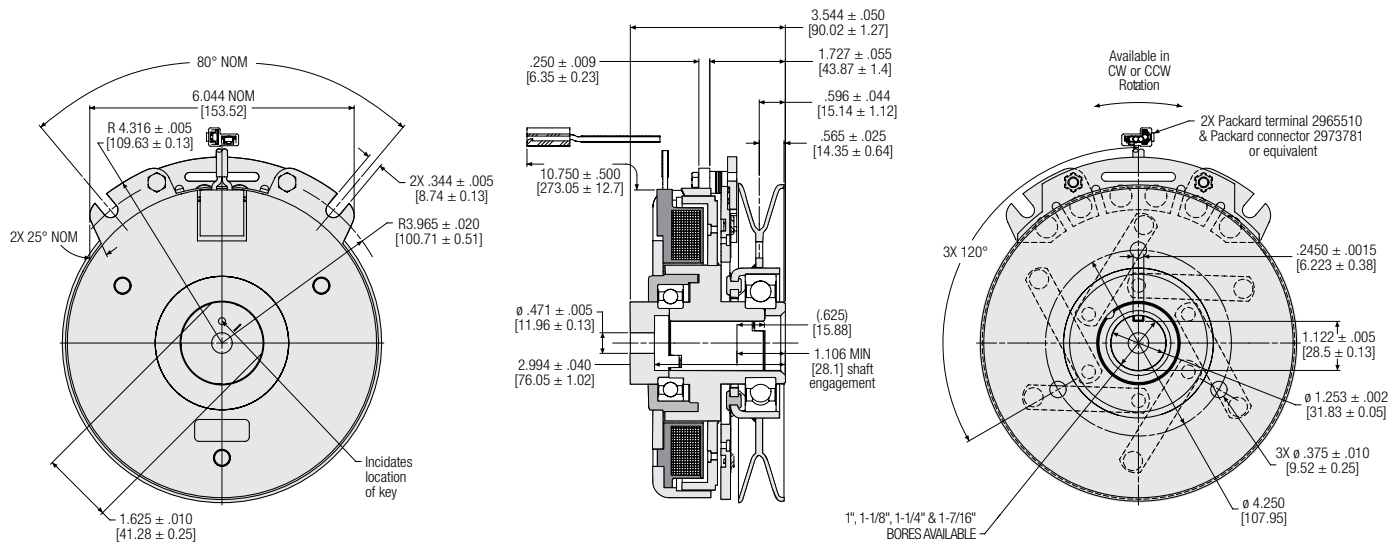

Garden Tractors



TG2000 CLUTCH/BRAKES

TG2000 incorporates the extended duty features of Warner Electric's Commercial MagStop clutch/brakes into a design specifically for tractors, ZTR's and wide area mowers in this class.

Lawn Tractors



RMS CLUTCH/BRAKES

Residential MagStop (RMS) clutch/brakes for mower decks and other implements controlled by a dashboard switch. No belt tighteners or mechanical linkage, simple electrical connection. Adjustment and maintenance free.

Walk Behind Mowers

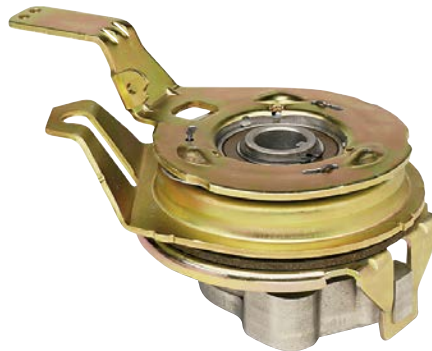

BBC-II CLUTCH/BRAKES

BBC-II clutch/brake allows motor to continue running while blade is stopped. Cable operated.

No adjustment, maintenance free.

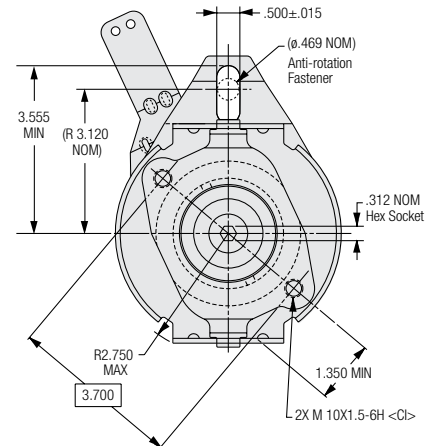
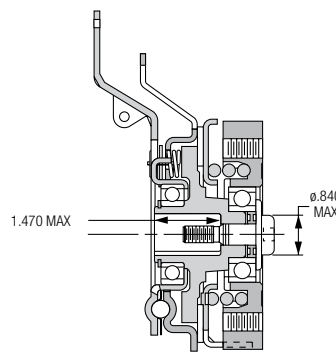
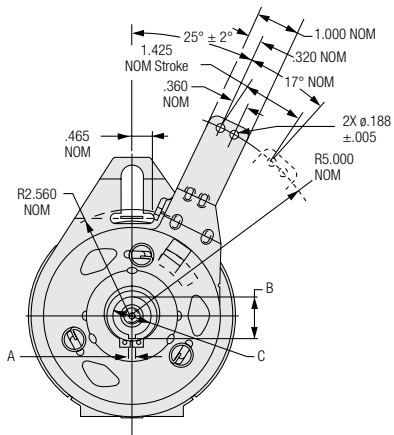
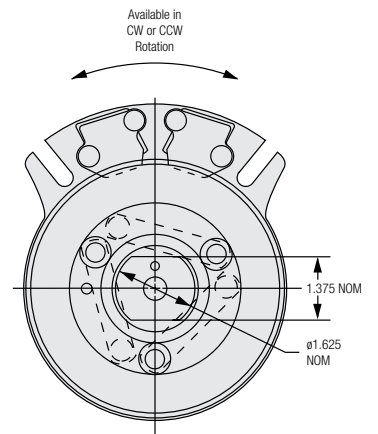
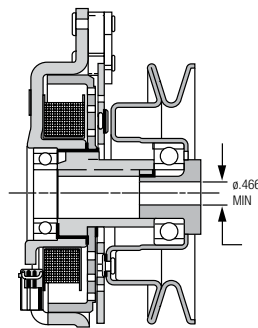
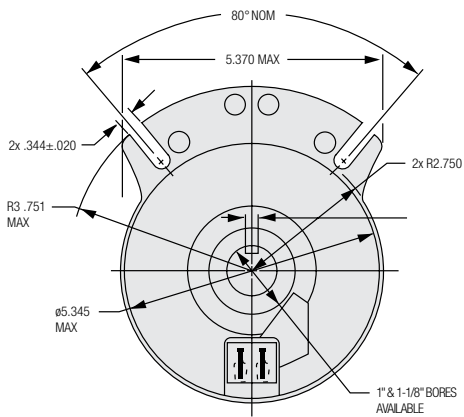
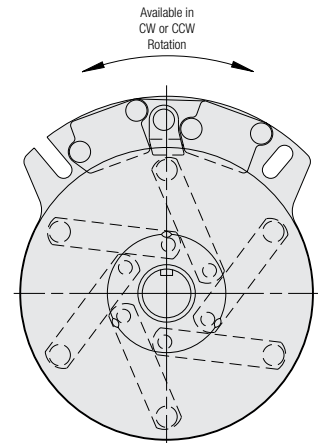
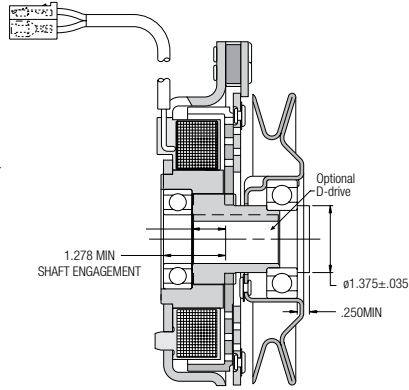
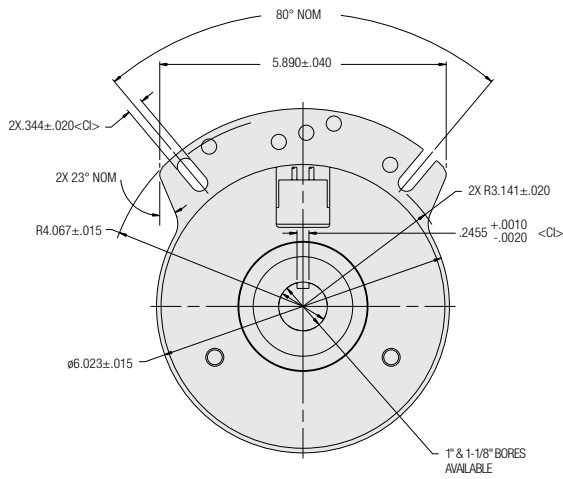



WARNER ELECTRIC™

Regal Rexnord

www.warnerelectric.com

www.warnerelectric-eu.com

31 Industrial Park Road
New Hartford, CT 06057 - USA
815-389-3771

7 rue de Champ eur - CS2009549182
St Barthelemy d'Anjou - France
+33 (0) 2 41 21 24 24

regalrexnord.com

The proper selection and application of products and components, including assuring that the product is safe for its intended use, are the responsibility of the customer. To view our Application Considerations, please visit <https://www.regalrexnord.com/Application-Considerations>.

To view our Standard Terms and Conditions of Sale, please visit <https://www.regalrexnord.com/Terms-and-Conditions-of-Sale> (which may redirect to other website locations based on product family).

"Regal Rexnord" is not indicative of legal entity. Refer to product purchase documentation for the applicable legal entity. Regal Rexnord and Warner Electric are trademarks of Regal Rexnord Corporation or one of its affiliated companies. © 2023, 2025 Regal Rexnord Corporation, All Rights Reserved. MCC-P-1698-WE-EN-US 09/25

 **RegalRexnord**™