

EUM Series Enclosed UniModule

EUM Series Clutch/Brakes and Clutch Combinations

Totally Enclosed Version

The Enclosed UniModule (EUM) packages the hardworking components from EM and UM products into a totally enclosed housing. This rugged housing keeps wear particles in and contaminants out and provides quiet operation. Pre-aligned at the factory, and pre-burnished for rated torque directly out-of-box.

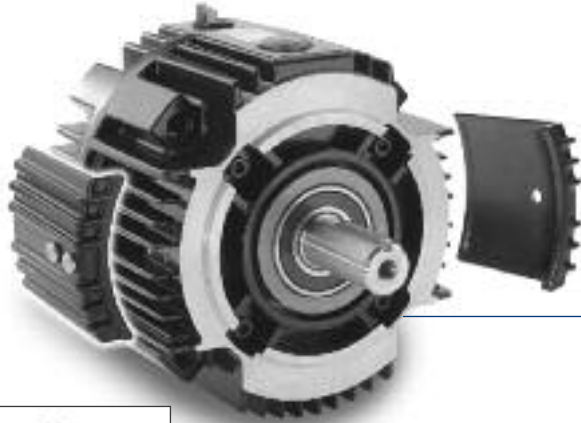

For 50, 100 and 180 Sizes

Enclosed UniModules, (EUMs) for 50, 100, and 180 sizes, are being replaced by GEN 2 UniModules (UMs) and an easy to install cover kit.



GEN 2 Design

For 210 and 215 Sizes

Original EUM (black) units are totally enclosed. They are suitable for most industrial applications and tolerate infrequent, light washing. They have aluminum endbells and a finned housing for rapid heat dissipation.



Original Design

EUM Series Enclosed UniModule

50, 100, and 180 sizes

Contamination-Resistant Design

Clean, quiet, operation. Nothing can get in, nothing can get out. Enclosed design eliminates damage to the working components. Prevents friction wear particles from escaping.

Totally Enclosed Version

The Enclosed UniModule (EUM) packages the hardworking components from UM products into a totally enclosed housing. This rugged housing keeps wear particles in and contaminants out and provides quiet operation. Pre-burnished at the factory for rated torque directly out-of-box. When enclosed, they are suitable for most industrial applications and tolerate infrequent, light washing.

- Keeps contaminants out
- Keeps wear particles in
- Quiet operation
- Finned for heat dissipation
- UL listed when optional conduit box is installed

To convert any Gen 2 UniModule 50, 100, and 180 sizes to an EUM, purchase optional Cover Kit

(part number 5370-101-076)

Enclosed UniModule Conversion

Enclosed UniModules, (EUMs) for 50, 100, and 180 sizes, are being replaced by GEN 2 UniModules (UMs) and an easy to install cover kit. Each kit contains (2) vent covers, (2) gaskets and (4) screws. A vent cover bolts to both sides of the UniModule unit to enclose the open vents of the housing creating a totally enclosed (non-washdown) brake package which keeps contaminants out and wear particles in for clean, quiet operation.



GEN 2 Heat Dissipation Curves

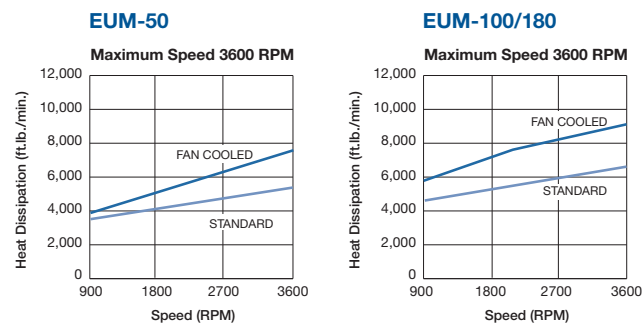

Note: For ORIGINAL DESIGN EUM 50,100 and 180 curves, see page 62.

How To Order

GEN 2 EUM models can be ordered in the following two ways:

1. Combined part number, UniModule including cover kit (ex. 5370-15)
2. Separate part numbers, UniModule and cover kit (ex. 5370-273-201 and 5370-101-076)

Totally Enclosed EUM Model No.	Voltage D.C.	Original Design Part No.	COMBINED OR SEPARATE	
			GEN 2 Part No. UniModule w/kit	GEN 2 Part Numbers UniModule and Cover Kit
1020 Configuration				
EUM-50-1020	6	5370-273-058	5370-15	5370-273-201 and 5370-101-076
	24	5370-273-059	5370-16	5370-273-203 and 5370-101-076
	90	5370-273-057	5370-17	5370-273-204 and 5370-101-076
EUM-100-1020	6	5370-273-092	5370-18	5370-273-206 and 5370-101-076
	24	5370-273-093	5370-19	5370-273-208 and 5370-101-076
	90	5370-273-091	5370-20	5370-273-209 and 5370-101-076
EUM-180-1020	6	5370-273-066	5370-21	5370-273-211 and 5370-101-076
	24	5370-273-067	5370-22	5370-273-213 and 5370-101-076
	90	5370-273-065	5370-23	5370-273-214 and 5370-101-076
1040 Configuration				
EUM-50-1040	90	5370-271-050	5370-24	5370-271-204 and 5370-101-076
EUM-180-1040	90	5370-271-051	5370-25	5370-271-214 and 5370-101-076
2030 Configuration				
EUM-50-2030	6	5370-273-062	5370-26	5370-273-216 and 5370-101-076
	24	5370-273-063	5370-27	5370-273-218 and 5370-101-076
	90	5370-273-061	5370-28	5370-273-219 and 5370-101-076
EUM-180-2030	6	5370-273-070	5370-29	5370-273-226 and 5370-101-076
	24	5370-273-071	5370-30	5370-273-228 and 5370-101-076
	90	5370-273-069	5370-31	5370-273-229 and 5370-101-076

EUM Series Enclosed UniModule

210 and 215 sizes

Clean, quiet, operation. Nothing can get in, nothing can get out. Enclosed design eliminates damage to the working components. Prevents friction wear particles from escaping.

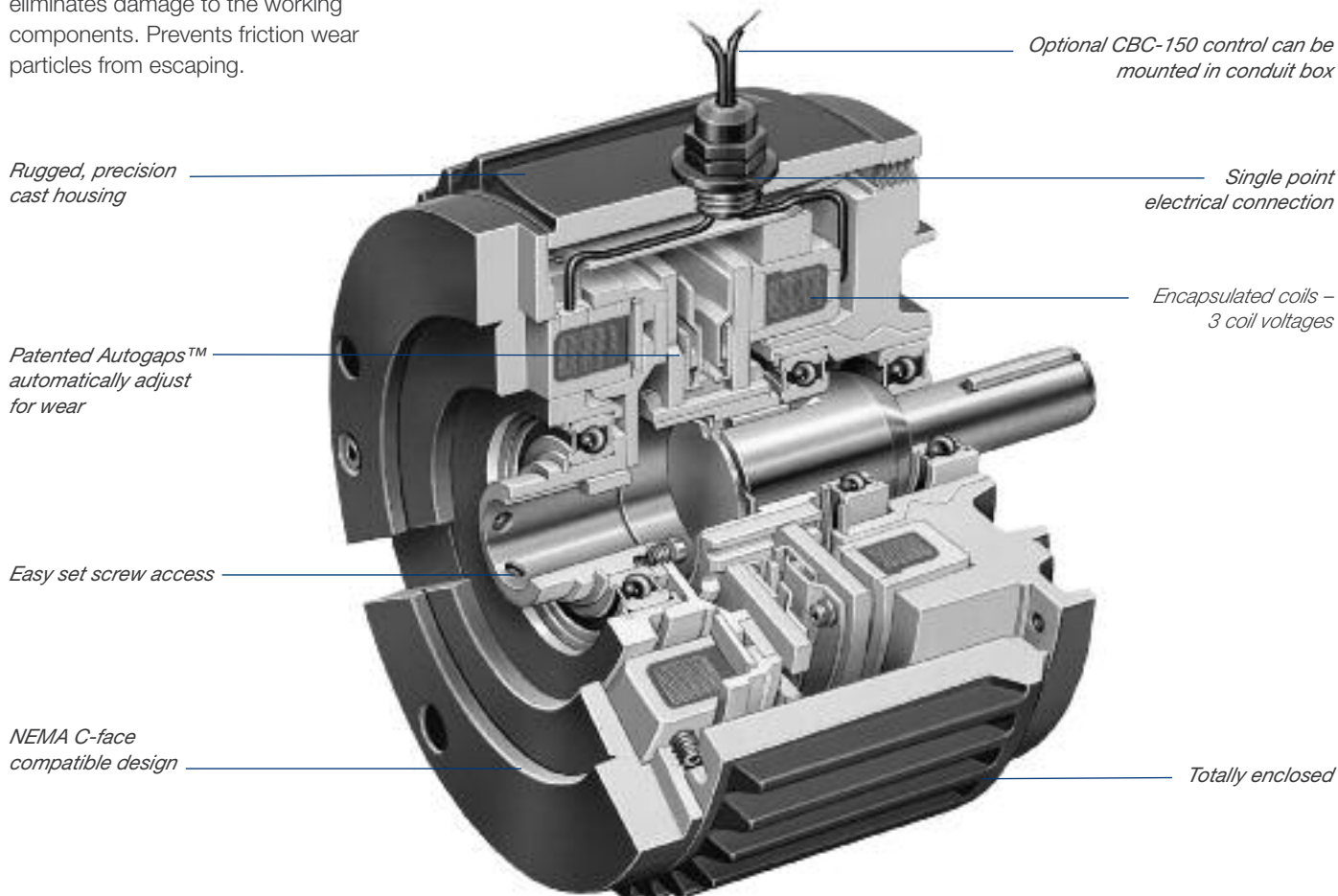

One piece, C-face package completely assembled and factory aligned. Mates easily with standard motors and reducers. Foot mounted package also available. Easy-to-install and no maintenance required.

Bolt-it-down, wire-it-up. UniModule is ready to go. Automatic adjustment for wear. Complete control capability.

Available with built-in power supply or used with separate controls for soft starts and stops . . . or for fast acting, accurate cycling.

- Factory burnished for out-of-box torque
- Superior heat transfer
- Dual endbell for easy repair
- Single point electrical connection
- Optional conduit box
- Optional integral control

Improved Hub Design/Autogap System

- Improved for longer spline life
- Autogap functions over broad current range
- New hub material

EUM Totally Enclosed

EUM (black) units are totally enclosed to keep wear particles in and exclude contaminants and are suitable for most industrial applications.

EUM Series Enclosed UniModule

Selection

EUM - Selection Procedure

Warner Electric EUM clutch/brake modules normally mount in either of two methods: NEMA C-face mounting or base mounting.

1. Select Configuration

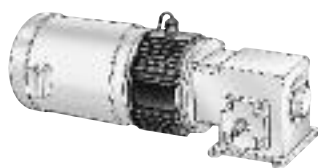

a. NEMA C-face Mounting (1020 and 1040 Configurations)

Based on the NEMA C-face frame size of the prime mover, select the corresponding clutch/brake package size from the Frame Size Selection chart. Size 100 houses the components of the size 180 in a size 50 frame, while size 215 incorporates size 210 components.

Select either a 1020 or a 1040 (EUM only) configuration. The 1020 is a clutch/brake, while the 1040 is a clutch only. The 2030 configuration is a clutch/brake for base mounting.

Frame Size Selection

NEMA Frame Size	EUM Size
56C/48Y	EUM-50* EUM-100**
182C/143TC 184C/145TC	EUM-180
213C/182TC 215C/184TC	EUM-210
213TC/215TC	EUM-215

* For 56C/48Y Frame motors 3/4 HP and smaller the EUM-100 size may be used where extended life is desirable.
** EUM-100 size is recommended for motors 1 HP and larger.

b. Base Mounting (2030 Configuration)



Enclosed UniModule assemblies may be mounted as separate drive units driven from the prime mover by V-belts, chain and sprockets, couplings, timing belts and other standard power transmission components.

Select the correct size 2030 package from the Horsepower vs. Shaft Speed chart by determining the motor horsepower and RPM at the module location. The correct size EUM is shown at the intersection of the HP and operating speed. For additional sizing information, refer to the technical sizing procedure (step 2).

2. Determine Technical Requirements

Technical considerations for sizing and selection are torque and heat dissipation. Each merits careful consideration, especially heat dissipation as over time, use in excessive temperature environments will have an adverse effect on bearing life and coil wire insulation integrity.

Compare the calculated torque requirement with the average dynamic torque ratings. Select a unit with adequate torque. If the unit selected on torque is different than the unit selected based on heat, select the larger size unit.

Two heat dissipation curves are shown. A fan kit accessory is available for use with these units.

Horsepower vs. Shaft Speed

HP	SHAFT SPEED AT CLUTCH (IN RPM)																		
	100	200	300	400	500	600	700	800	900	1000	1100	1200	1500	1800	2000	2400	3000	3600	
1/4																			
1/2																			
3/4																			
1																			
1-1/2																			
2																			
3																			
5																			
7-1/2																			
10																			

a. Heat Dissipation Sizing

Friction surfaces slip during the initial period of engagement and, as a result, heat is generated. The clutch/brake selected must have a heat dissipation rating greater than the heat generated by the application. Therefore, in high inertia or high cycle rate applications, it is necessary to check the heat dissipation carefully. Inertia, speed and cycle rate are the required parameters.

Heat dissipation requirement is calculated as follows:

$$E = 1.7 \times WR^2 \times (N/100)^2 \times F$$

where:

$$E = \text{Heat (lb. ft./min.)}$$

WR^2 = Total reflected inertia at the clutch/brake shaft. Include the clutch/brake output inertia. (lb.ft.²)

N = Speed in revolutions per minute (RPM)

F = Cycle rate in cycles per minute (CPM)

Compare the calculated heat generated in the application to the unit ratings using the heat dissipation curves. Select the appropriate unit that has adequate heat dissipation ability.

Enclosed UniModule Heat Dissipation Curves

EUM-50

Maximum Speed 3600 RPM

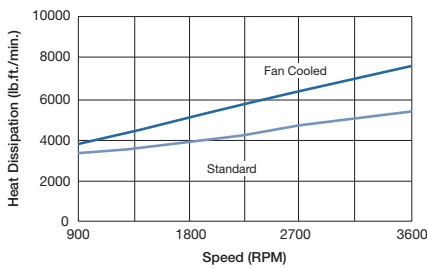

EUM-100/180

Maximum Speed 3600 RPM

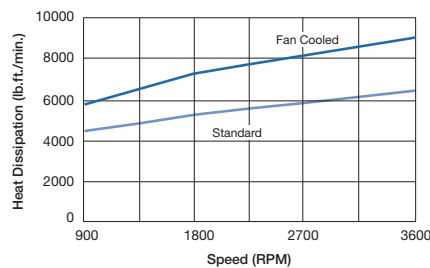

EUM 210/215 (fan not available for 215)

Maximum Speed 3600 RPM

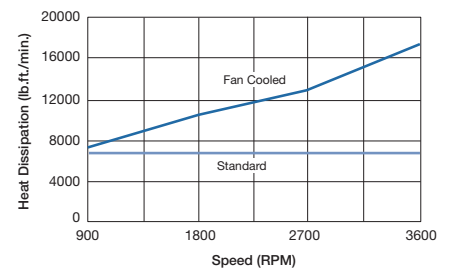

b. Torque Sizing

For most applications, the correct size clutch/brake can be selected from the Horsepower vs. Shaft Speed chart.

Determine the motor horsepower and the RPM at the clutch/brake. The correct size unit is shown at the intersection of horsepower and shaft speed.

If the static torque requirements are known, refer to the Specifications Table to select a unit.

For some applications, the torque requirement is determined by the time allowed to accelerate and decelerate the load. (This time is generally specified in milliseconds.) For these applications, it is necessary to determine the torque requirement based on load inertia and the time allowed for engagement.

The torque requirements are calculated as follows:

$$T = (WR^2 \times N) / (308 \times t)$$

where:

T = Average Dynamic Torque (lb. ft.)

WR^2 = Total reflected inertia at the clutch/brake shaft. Include the clutch/brake output inertia. (lb. ft.²)

N = Speed in revolutions per minute (RPM)

t = Time allowed for the engagement (sec)

C-face Clutch/Power-on Brake Dynamic Torque Curves

EUM 50

Maximum Speed 3600 RPM
Static Torque 16 lb.ft.

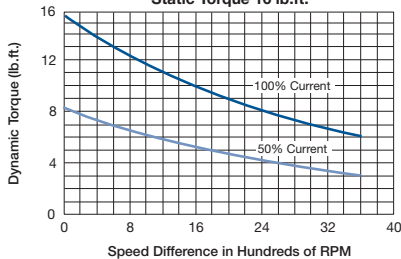

EUM 100/180

Maximum Speed 3600 RPM
Static Torque 30 lb.ft.

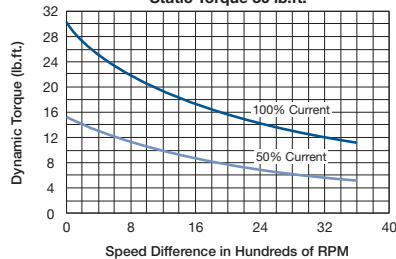

EUM 210/215

Maximum Speed 3600 RPM
Static Torque 95 lb.ft.

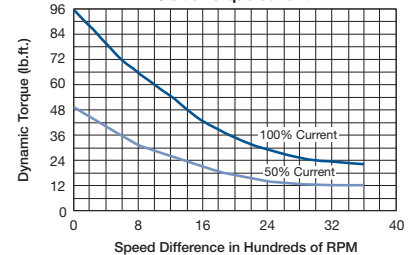

EUM Series Enclosed UniModule

Specifications

UniModule Size	Shaft Dia.	Static Torque lb. ft.	Horsepower	Max. RPM	Voltage DC	NEMA Frame Size
EUM50	.625	16	1/4-3/4	3600	6, 24 and 90	56C/48Y
EUM100	.625	30	1-2	3600	6, 24 and 90	56C/48Y
EUM180	.875	30	1-2	3600	6, 24 and 90	182C/143TC 184C/145TC
EUM210	1.125	95	3-5	3600	6, 24 and 90	213/182TC 215C/184TC
EUM215	1.375	95	7-1/2-10	3600	6, 24 and 90	213TC/215TC

Accessories

Warner Electric Enclosed UniModules can be fitted with several accessories to extend their capacity and ease of mounting.

Conduit Box

NEMA 4 and UL listed, available in standard and washdown versions.



Integral Control

The CBC-150 dual channel control fits into the cover of the conduit box. It is suitable for AC side switching (triac or relay) and includes high performance suppression.



Fan Kit (UM and EUM 1020 only)

Extends the thermal capacity of an EUM. Mounts between motor and EUM, includes shaft, fan, guard and hardware. Available in standard black coating or food grade approved white coating.



Mounting Brackets

Two styles of mounting brackets are available for simplified installation. The base mount is used with the 2030 configuration. A motor mount is also available and provides sturdy support for a 1020 or 1040 combination with motor.

(Optional)

Motor Mount (M)

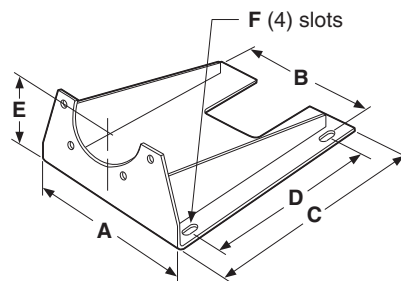

For use with 1020 and 1040 Combinations.

Size	A	B	C	D	E	F	Part No.
50/100	9.25	8.25	11.00	8.000	3.50	.797 x .406	5370-101-078
180	9.25	8.25	11.00	8.000	4.50	.797 x .406	5370-101-079
210/215	11.50	10.50	12.00	9.000	5.25	.750 x .406	5371-101-012

Base (B)

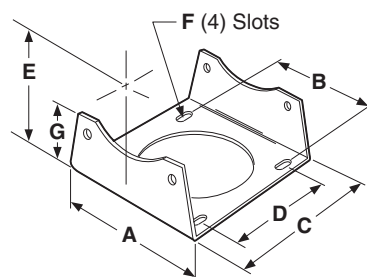

For use with 2030 and 3040 units.

Size	A	B	C	D	E	F	G	Part No.
50/100	6.000	5.000	5.672	4.000	3.500	.750 x .406	2.000	5370-101-004
180	6.625	5.000	5.672	4.000	4.500	.750 x .406	3.000	5370-101-002
210/215	9.000	7.750	8.203	6.000	5.250	.750 x .531	3.385	5371-101-001

EUM Series Enclosed UniModule

Selection and Ordering Information

Part Numbers

Totally Enclosed EUM Model No.	Voltage D.C.	Original Design Part No.	COMBINED GEN 2 Part No. UniModule w/kit	OR	SEPARATE GEN 2 Part Numbers	
					UniModule	and Cover Kit
1020 Configuration – Enclosed EUM						
EUM-50-1020	6	5370-273-058	5370-15		5370-273-201	and 5370-101-076
	24	5370-273-059	5370-16		5370-273-203	and 5370-101-076
	90	5370-273-057	5370-17		5370-273-204	and 5370-101-076
EUM-100-1020	6	5370-273-092	5370-18		5370-273-206	and 5370-101-076
	24	5370-273-093	5370-19		5370-273-208	and 5370-101-076
	90	5370-273-091	5370-20		5370-273-209	and 5370-101-076
EUM-180-1020	6	5370-273-066	5370-21		5370-273-211	and 5370-101-076
	24	5370-273-067	5370-22		5370-273-213	and 5370-101-076
	90	5370-273-065	5370-23		5370-273-214	and 5370-101-076
EUM-210-1020	6	5371-273-028				
	24	5371-273-029				
	90	5371-273-027				
EUM-215-1020	6	5371-273-082				
	24	5371-273-083				
	90	5371-273-084				
20 Configuration (Power On Brake Only) – Enclosed EUM						
EUM-210-20	24	5371-169-105				
	90	5371-169-104				
EUM-215-20	24	5371-169-105				
	90	5371-169-104				
1040 Configuration – Enclosed EUM						
EUM-50-1040	90	5370-271-050	5370-24		5370-271-204	and 5370-101-076
EUM-180-1040	90	5370-271-051	5370-25		5370-271-214	and 5370-101-076
EUM-210-1040	90	5371-271-024				
2030 Configuration – Enclosed EUM						
EUM-50-2030	6	5370-273-062	5370-26		5370-273-216	and 5370-101-076
	24	5370-273-063	5370-27		5370-273-218	and 5370-101-076
	90	5370-273-061	5370-28		5370-273-219	and 5370-101-076
EUM-180-2030	6	5370-273-070	5370-29		5370-273-226	and 5370-101-076
	24	5370-273-071	5370-30		5370-273-228	and 5370-101-076
	90	5370-273-069	5370-31		5370-273-229	and 5370-101-076
EUM-210-2030	6	5371-273-032				
	24	5371-273-033				
	90	5371-273-031				

Accessories

Option	Size	Enclosed UniModule
Conduit box	All sizes	5370-101-042
Control	CBC-150-1	6004-448-001
	CBC-150-2	6004-448-002
Base Mount Kits for 2030	50	5370-101-004
	50/180*	5370-101-002
	210	5371-101-001
Motor Mount Kits for 1020, 1040, 20	50/100	5370-101-078
	50/100/180*	5370-101-079
	210/215	5371-101-012
Fan Kits for 1020, 1040	50/100	5370-101-055
	180	5370-101-054
	210	5371-101-029

* Because of diameter limitations, bases for original design EUMs are available in 4.5" center height (143/145TC) only.

How to Order

Motor or Reducer Mounted

Simply combine the size number with the configuration of the required UniModule. Specify voltage. See chart for specific part numbers. Order optional conduit box if desired.

Example

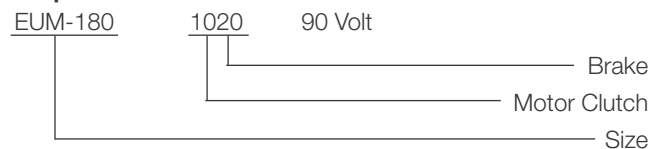

Base Mounted

Simply combine the size number with the configuration of the required UniModule. Specify voltage. See chart for specific part numbers. Order optional conduit box if desired.

Example

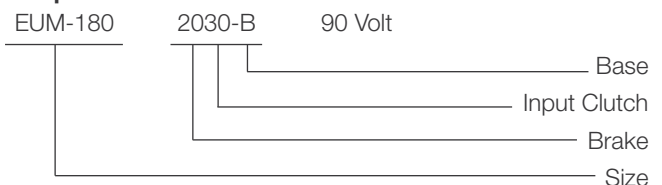

EUM Series Enclosed UniModule

EUM-1020 Motor Clutch/Brake Combination

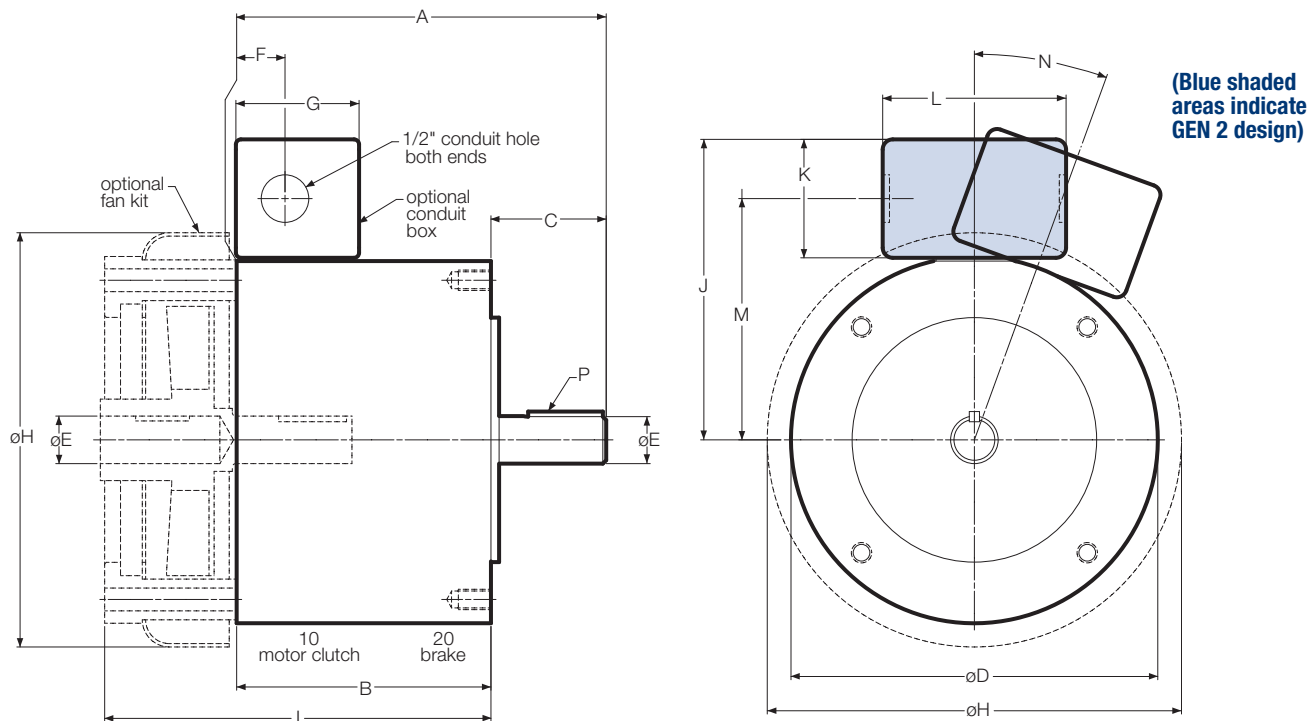

Dimensions (Blue shaded areas indicate GEN 2 design)

Size	A	B	C	D	E	F	G	H
50	6.720	4.680	2.040	6.750	.625	.890	2.267	7.620
100	6.741	4.680	2.061	6.750	.625	.890	2.267	7.620
180	6.801	4.680	2.121	6.750	.875	.890	2.267	7.620
210	9.391*	6.422*	2.500	10.000	1.125	3.053	2.267	10.187
215	9.391*	6.422*	2.500	10.000	1.375	3.053	2.267	10.187

Size	I	J	K	L	M	N	P
50	7.110	5.516	2.180	3.250	4.426	0°	3/16 x 3/16
100	7.110	5.516	2.180	3.250	4.426	0°	3/16 x 3/16
180	7.110	5.516	2.180	3.250	4.426	0°	3/16 x 3/16
210	9.297	7.146	2.180	3.250	6.056	35°	1/4 x 1/4
215	9.297	7.146	2.180	3.250	6.056	35°	5/16 x 5/16

* Dimension includes the .500 thick adapter required for mounting to a C-face motor.

Specifications (Blue shaded areas indicate GEN 2 design)

Model Size	Voltage DC	Static Torque lb. ft.	Max. RPM	NEMA Frame Size
50	6, 24, 90	16	3600	56C/48Y*
100	6, 24, 90	30	3600	56C/48Y**
180	6, 24, 90	30	3600	182C/143TC 184C/145TC
210	6, 24, 90	95	3600	213C/182TC 215C/184TC
215	6, 24, 90	95	3600	213TC/215TC

* For 56C/48Y Frame motors 3/4 HP and smaller the UM-100 size may be used where extended life is desirable.

** UM-100 size is recommended for motors 1 HP and larger.

For standard NEMA frame dimensions, see page 187.

Only 50, 100, and 180 sizes of the models listed will be converted to the new GEN 2 design. 210 and 215 sizes will continue to be offered in the original design and will not be converted.

EUM Series Enclosed UniModule

EUM-1040 Motor Clutch/Output Clutch Combination

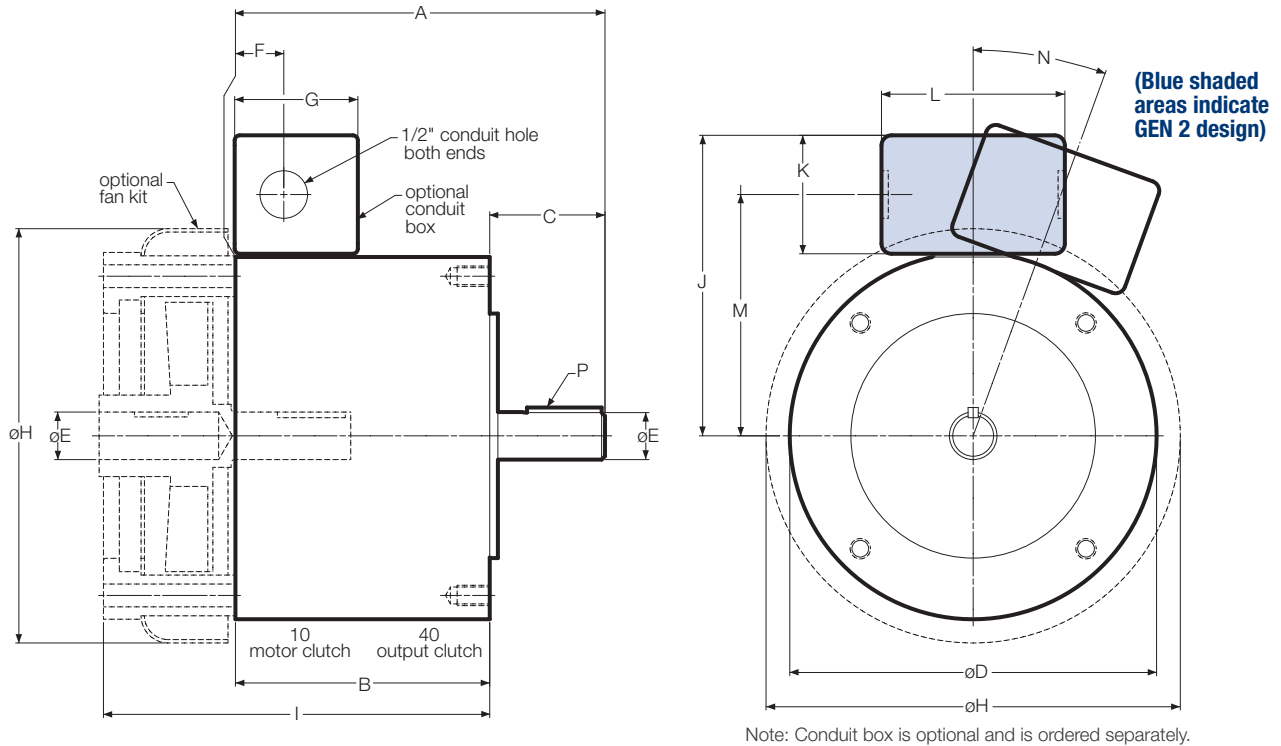

Dimensions (Blue shaded areas indicate GEN 2 design)

Size	A	B	C	D	E	F	G	H
50	6.720	4.680	2.040	6.750	.625	.890	2.267	7.620
180	6.801	4.680	2.121	6.750	.875	.890	2.267	7.620
210	9.391*	6.422*	2.500	10.000	1.125	3.053	2.267	10.187

Size	I	J	K	L	M	N	P
50	7.110	5.516	2.180	3.250	4.426	0°	3/16 x 3/16
180	7.110	5.516	2.180	3.250	4.426	0°	3/16 x 3/16
210	9.297	7.146	2.180	3.250	6.056	35°	1/4 x 1/4

* Dimension includes the .500 thick adapter required for mounting to a C-face motor.

Specifications (Blue shaded areas indicate GEN 2 design)

Model Size	Voltage DC	Static Torque lb. ft.	Max. RPM	NEMA Frame Size
50	90	16	3600	56C/48Y
180	90	30	3600	182C/143TC 184C/145TC
210	90	95	3600	213C/182TC 215C/184TC

For standard NEMA frame dimensions, see page 187.

Only 50 and 180 sizes of the models listed will be converted to the new GEN 2 design. 210 size will continue to be offered in the original design and will not be converted.

EUM Series Enclosed UniModule

EUM-2030 Input Clutch/Brake Combination

EUM-2030-B Input Clutch/Brake Combination – Base Mounted

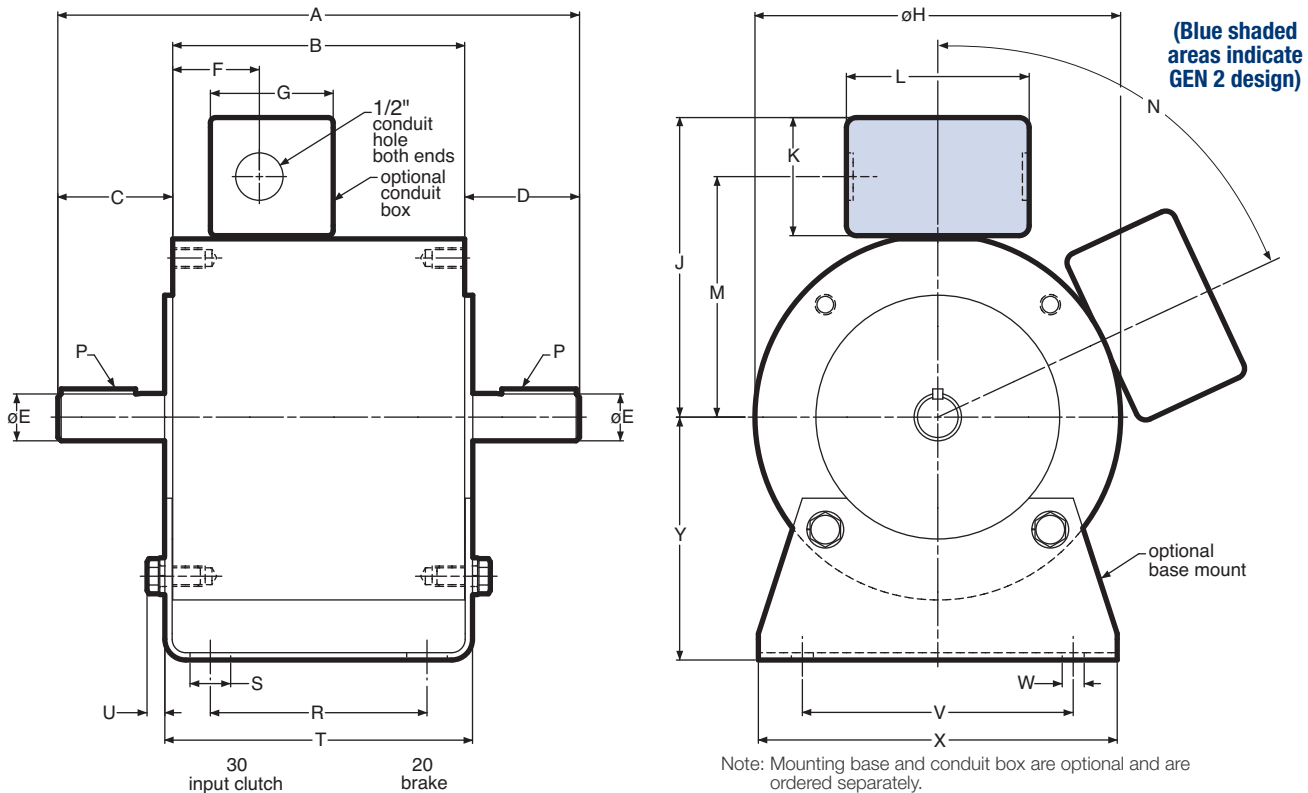

Dimensions (Blue shaded areas indicate GEN 2 design)

Size	A	B	C	D	E	F	G	H	J	K	L	M
50	9.492	5.390	2.062	2.040	.625	1.600	2.267	6.750	5.516	2.180	3.250	4.426
180	9.632	5.390	2.121	2.121	.875	1.600	2.267	6.750	5.516	2.180	3.250	4.426
210	12.969	7.719	2.500	2.500	1.125	4.514	2.267	10.000	7.146	2.180	3.250	6.056

Size	N	P	R	S	T	U	V	W	X	Y
50	0°	3/16 x 3/16	4.000	.800	5.680	.329	5.000	.406	6.000	3.500
180	0°	3/16 x 3/16	4.000	.750	5.680	.329	5.000	.406	6.625	4.500
210	35°	1/4 x 1/4	6.000	.750	8.260	.437	7.750	.534	9.000	5.250

Specifications (Blue shaded areas indicate GEN 2 design)

Model Size	Voltage DC	Static Torque lb. ft.	Max. RPM	NEMA Frame Size
50	6, 24, 90	16	3600	56C/48Y
180	6, 24, 90	30	3600	182C/143TC 184C/145TC
210	6, 24, 90	95	3600	213C/182TC 215C/184TC

For standard NEMA frame dimensions, see page 187.

Only 50 and 180 sizes of the models listed will be converted to the new GEN 2 design. 210 size will continue to be offered in the original design and will not be converted.